

*Recommended by the University of Calcutta, Dacca, Patna, Utkal etc.,
as a text-book for B. A. & B. Sc. Examinations*

INTEGRAL CALCULUS

INCLUDING

DIFFERENTIAL EQUATIONS

BY

B. C. DAS, M. Sc.

PROFESSOR OF MATHEMATICS, PRESIDENCY COLLEGE (RETD.),
CALCUTTA . EX-LECTURER IN APPLIED MATHEMATICS,
CALCUTTA UNIVERSITY

AND

B. N. MUKHERJEE, M. A.

Premchand Roychand Scholar

PROFESSOR OF MATHEMATICS, SCOTTISH
CHURCH COLLEGE (RETD.), CALCUTTA

EIGHTEENTH EDITION

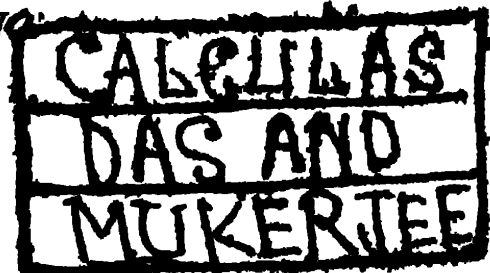

U. N. DHUR & SONS, PRIVATE LTD.

15, BANKIM CHATTERJEE STREET,

CALCUTTA 12

Published by
DWIJENDRANATH DHUR, B.L.
For U. N. DHUR & SONS, PRIVATE LTD.,
15, Bankim Chatterjee St., Calcutta 12

[*All rights reserved by the Authors*]

Printed by
TRIDIBESH BASU
THE K. P. BASU PTG. WORKS,
11, Mohendra Gossain Lane, Calcutta 6

PREFACE

THIS book is prepared with a view to be used as a text-book for the B.A. and B.Sc. students of the Indian Universities. We have tried to make the exposition of the fundamental principles clear as well as concise without going into unnecessary details ; and at the same time an attempt has been made to make the treatment as much rigorous and up-to-date as is possible within the scope of this elementary work.

We have devoted a separate chapter for the discussion of infinite (or improper) integrals and the integration of infinite series in order to emphasise their peculiarity upon the students. Important formulæ and results of Differential Calculus as also of this book are given in the beginning for ready reference. A good number of typical examples have been worked out by way of illustration.

Examples for exercises have been selected very carefully and include many which have been set in the Pass and Honours Examinations of different Universities. University questions of recent years have been added at the end to give the students an idea of the standard of the examination.

Our thanks are due to several friends for their helpful suggestions in the preparation of the work and especially to our pupil Prof. H. K. Ganguli, M. A. for verifying the answers of all the examples of the book.

Corrections and suggestions will be thankfully received.

CALCUTTA }
January, 1938 }

B. C. D.
B. N. M.

PREFACE TO THE SEVENTEENTH EDITION

WE have thoroughly revised the book in this edition. For the sake of the convenience of the students, the chapter on "Integration by Successive Reduction" which was in the Appendix in the previous edition, has been inserted at the end of the chapter on "Infinite (or Improper) Integrals". Our thanks are due to our pupil Prof. Tapen Maulik M. Sc. of the B. F. College, Shibpur for his help in the revision of the text.

B. C. D.
B. N. M.

PREFACE TO THE EIGHTEENTH EDITION

THE book has been thoroughly revised in accordance with the *revised syllabus* of Mathematics for the Three-Year Degree Examinations in Arts and Science. In this edition a few examples have been inserted here and there and a chapter on the integration of Irrational Functions has been added. We take this opportunity of thanking Mrs. S. Chatterjee and Prof. Gouri De M. Sc. for their help in the revision of the text.

B. C. D.
B. N. M.

$$(xiv) \quad \frac{d}{dx} (\sin^{-1} x) = \frac{1}{\sqrt{1-x^2}} \quad (-1 < x < 1)$$

$$(xv) \quad \frac{d}{dx} (\cos^{-1} x) = -\frac{1}{\sqrt{1-x^2}} \quad [-1 < x < 1]$$

$$(xvi) \quad \frac{d}{dx} (\tan^{-1} x) = \frac{1}{1+x^2}$$

$$(xvii) \quad \frac{d}{dx} (\cot^{-1} x) = -\frac{1}{1+x^2}$$

$$(xviii) \quad \frac{d}{dx} (\operatorname{cosec}^{-1} x) = -\frac{1}{x\sqrt{x^2-1}} \quad (|x| > 1)$$

$$(xix) \quad \frac{d}{dx} (\sec^{-1} x) = \frac{1}{x\sqrt{x^2-1}} \quad (|x| > 1)$$

$$(xx) \quad \frac{d}{dx} (\sinh x) = \cosh x$$

$$(xxi) \quad \frac{d}{dx} (\cosh x) = \sinh x$$

$$(xxii) \quad \frac{d}{dx} (\tanh x) = \operatorname{sech}^2 x$$

$$(xxiii) \quad \frac{d}{dx} (\coth x) = -\operatorname{cosech}^2 x$$

$$(xxiv) \quad \frac{d}{dx} (\operatorname{sech} x) = -\operatorname{sech} x \tanh x$$

$$(xxv) \quad \frac{d}{dx} (\operatorname{cosech} x) = -\operatorname{cosech} x \coth x$$

$$(xxvi) \quad \frac{d}{dx} (\sinh^{-1} x) = \frac{1}{\sqrt{x^2+1}}$$

$$(xxvii) \quad \frac{d}{dx} (\cosh^{-1} x) = \frac{1}{\sqrt{x^2-1}}, \quad (x > 1)$$

$$(xxviii) \quad \frac{d}{dx} (\tanh^{-1} x) = \frac{1}{1-x^2}, \quad (x^2 < 1)$$

$$(xxix) \frac{d}{dx} (\coth^{-1} x) = \frac{1}{1-x^2}, \quad (x^2 > 1)$$

$$(xxx) \frac{d}{dx} (\operatorname{cosech}^{-1} x) = \frac{-1}{x \sqrt{(x^2+1)}}$$

$$(xxxii) \frac{d}{dx} (\operatorname{sech}^{-1} x) = -\frac{1}{x \sqrt{(1-x^2)}}, \quad (0 < x < 1)$$

III. Important results associated with curves.

$$(i) \text{ Cartesian subtangent} = \frac{y}{y_1}$$

$$(ii) \text{ ,, subnormal} = yy_1.$$

$$(iii) \text{ ,, normal} = y \sqrt{1+y_1^2}.$$

$$(iv) \text{ ,, tangent} = \frac{y}{y_1} \sqrt{1+y_1^2}.$$

$$(v) \text{ Polar subtangent} = r^2 \frac{d\theta}{dr} = -\frac{d\theta}{du}; \quad \left(u = \frac{1}{r}\right)$$

$$(vi) \text{ ,, subnormal} = \frac{dr}{d\theta} = -\frac{1}{u^2} \frac{du}{d\theta}; \quad \left(u = \frac{1}{r}\right)$$

$$(vii) \tan \psi = \frac{dy}{dx}; \quad \cos \psi = \frac{dx}{ds}; \quad \sin \psi = \frac{dy}{ds}$$

$$(viii) \tan \phi = r \frac{d\theta}{dr}; \quad \cos \phi = \frac{dr}{ds}; \quad \sin \phi = r \frac{d\theta}{ds}$$

$$(ix) ds^2 = dx^2 + dy^2 = dr^2 + r^2 d\theta^2.$$

$$\left(\frac{ds}{dx}\right)^2 = 1 + \left(\frac{dy}{dx}\right)^2; \quad \left(\frac{ds}{dy}\right)^2 = 1 + \left(\frac{dx}{dy}\right)^2;$$

$$\left(\frac{ds}{dr}\right)^2 = 1 + r^2 \left(\frac{d\theta}{dr}\right)^2; \quad \left(\frac{ds}{d\theta}\right)^2 = r^2 + \left(\frac{dr}{d\theta}\right)^2.$$

$$(x) p = r \sin \phi; \quad \frac{1}{p^2} = \frac{1}{r^2} + \frac{1}{r^4} \left(\frac{dr}{d\theta}\right)^2 = u^2 + \left(\frac{du}{d\theta}\right)^2.$$

$$(xi) \rho = \frac{ds}{d\psi} = \frac{(1+y_1^2)^{\frac{3}{2}}}{y_1^2} = \frac{(r^2+r_1^2)^{\frac{3}{2}}}{r^2+2r_1^2-rr_2} = r \frac{dr}{dp} = p + \frac{d^2 p}{d\psi^2}.$$

CONTENTS

INTEGRAL CALCULUS

CHAP.		PAGE
I.	Definition and Fundamental Properties	1
II.	Method of Substitution	14
III.	Integration by Parts	38
IV.	Special Trigonometric Functions	57
V.	Rational Fractions	78
VI.	Definite Integrals	91
VII.	Infinite (or Improper) Integrals and Integration of Infinite Series	132
VII(A).	Irrational Functions	146
VIII.	Integration by Successive Reduction and Beta & Gamma Functions	163
IX.	Areas of Plane Curves (Quadrature)	205
X.	Lengths of Plane Curves (Rectification)	240
XI.	Volumes and Surface-Areas of Solids of Revolution	259
XII.	Centroids and Moments of Inertia	273
XIII.	On Some Well-known Curves	286
<i>DIFFERENTIAL EQUATIONS</i>		
XIV.	Introduction and Definitions	302
XV.	Equations of the first order and the first degree	310
XVI.	Equations of the first order but not of the first degree	332

CHAP.	PAGE
xvii. Linear Equations with constant coefficients	340
xviii. Applications	372
xix. The Method of Isoclines	385
Appendix	387
Sec. A. A note on Definite Integrals ...	387
Sec. B. A note on Logarithmic and Exponential Functions	397
Sec. C. Alternative Proofs of some Theorems ...	401
Sec. D. A note on Integrating Factors ...	407
Index	411

ABBREVIATIONS USED IN THE BOOK

1. *I.* stands for "the Integral".
 2. *C.P.* stands for "set in the B. A. and B. Sc. Pass Examinations of the Calcutta University".
 3. *C.H.* stands for "set in the B. A. and B. Sc. Honours Examinations of the Calcutta University".
 4. *P.P.* stands for "set in the B. A. and B. Sc. Pass Examinations of the Patna University".
-

IMPORTANT FORMULÆ AND RESULTS

of

(A) TRIGONOMETRY

I. Fundamental relations.

$$\left. \begin{array}{l} \text{(i) } \sin^2 \theta + \cos^2 \theta = 1 \\ \text{(ii) } \sec^2 \theta = 1 + \tan^2 \theta \\ \text{(iii) } \operatorname{cosec}^2 \theta = 1 + \cot^2 \theta \end{array} \right\} \begin{array}{l} \text{(iv) } \sin(-\theta) = -\sin \theta \\ \text{(v) } \cos(-\theta) = \cos \theta \\ \text{(vi) } \tan(-\theta) = -\tan \theta \end{array}$$

II. Multiple angles.

$$\text{(i) } \sin 2A = 2 \sin A \cos A.$$

$$\text{(ii) } \cos 2A = \cos^2 A - \sin^2 A = 1 - 2 \sin^2 A = 2 \cos^2 A - 1.$$

$$\text{(iii) } \sin 2A = \frac{2 \tan A}{1 + \tan^2 A}; \quad \text{(vi) } \cos 2A = \frac{1 - \tan^2 A}{1 + \tan^2 A}.$$

$$\left. \begin{array}{l} \text{(iv) } 1 - \cos 2A = 2 \sin^2 A \\ \text{(v) } 1 + \cos 2A = 2 \cos^2 A \end{array} \right\} \text{(vii) } \tan^2 A = \frac{1 - \cos 2A}{1 + \cos 2A}.$$

$$\text{(viii) } 1 + \sin 2A = (\sin A + \cos A)^2.$$

$$\text{(ix) } 1 - \sin 2A = (\sin A - \cos A)^2.$$

$$\text{(x) } \sin 3A = 3 \sin A - 4 \sin^3 A.$$

$$\text{(xi) } \cos 3A = 4 \cos^3 A - 3 \cos A.$$

$$\text{(xii) } \tan 3A = \frac{3 \tan A - \tan^3 A}{1 - 3 \tan^2 A}.$$

$$\text{(xiii) } \cot 3A = \frac{\cot^3 A - 3 \cot A}{3 \cot^2 A - 1}.$$

III. Special Angles.

$$\left. \begin{array}{l} \sin 0^\circ = 0 \\ \cos 0^\circ = 1 \\ \tan 0^\circ = 0 \end{array} \right\} \begin{array}{l} \operatorname{cosec} 0^\circ = \infty \\ \sec 0^\circ = 1 \\ \cot 0^\circ = \infty \end{array}$$

$$\left. \begin{array}{l} \sin 90^\circ = 1 \\ \cos 90^\circ = 0 \\ \tan 90^\circ = \infty \end{array} \right\} \quad \left. \begin{array}{l} \operatorname{cosec} 90^\circ = 1 \\ \sec 90^\circ = \infty \\ \cot 90^\circ = 0 \end{array} \right\}$$

$$\left. \begin{array}{l} \sin 30^\circ = \frac{1}{2} \\ \cos 30^\circ = \frac{1}{2} \sqrt{3} \\ \tan 30^\circ = 1/\sqrt{3} \end{array} \right\} \quad \left. \begin{array}{l} \sin 60^\circ = \frac{1}{2} \sqrt{3} \\ \cos 60^\circ = \frac{1}{2} \\ \tan 60^\circ = \sqrt{3} \end{array} \right\}$$

$$\left. \begin{array}{l} \sin 45^\circ = 1/\sqrt{2} \\ \cos 45^\circ = 1/\sqrt{2} \\ \tan 45^\circ = 1 \end{array} \right\} \quad \left. \begin{array}{l} \sin 180^\circ = 0 \\ \cos 180^\circ = -1 \\ \tan 180^\circ = 0 \end{array} \right\}$$

$$\sin 120^\circ = \frac{1}{2} \sqrt{3} \quad \cos 120^\circ = -\frac{1}{2}$$

$$\sin 15^\circ = \frac{\sqrt{3}-1}{2\sqrt{2}}; \quad \cos 15^\circ = \frac{\sqrt{3}+1}{2\sqrt{2}}$$

$$\tan 15^\circ = 2 - \sqrt{3}.$$

$$\sin 75^\circ = \frac{\sqrt{3}+1}{2\sqrt{2}}; \quad \cos 75^\circ = \frac{\sqrt{3}-1}{2\sqrt{2}}$$

$$\tan 75^\circ = 2 + \sqrt{3}.$$

$$\sin 18^\circ = \frac{1}{4}(\sqrt{5}-1); \quad \cos 36^\circ = \frac{1}{4}(\sqrt{5}+1).$$

$$\sin 22\frac{1}{2}^\circ = \frac{1}{2}\sqrt{(2-\sqrt{2})}; \quad \cos 22\frac{1}{2}^\circ = \frac{1}{2}\sqrt{(2+\sqrt{2})}.$$

IV. Inverse Trigonometric functions.

$$(i) \operatorname{cosec}^{-1}x = \sin^{-1} \frac{1}{x}; \quad \cot^{-1}x = \tan^{-1} \frac{1}{x};$$

$$\sec^{-1}x = \cos^{-1} \frac{1}{x}.$$

$$(ii) \sin^{-1}x + \cos^{-1}x = \frac{1}{2}\pi.$$

$$(iii) \tan^{-1}x + \cot^{-1}x = \frac{1}{2}\pi.$$

$$(iv) \operatorname{cosec}^{-1}x + \sec^{-1}x = \frac{1}{2}\pi.$$

$$(v) \tan^{-1}x + \tan^{-1}y = \tan^{-1} \frac{x+y}{1-xy}.$$

$$(vi) \tan^{-1}x - \tan^{-1}y = \tan^{-1} \frac{x-y}{1+xy}.$$

$$(vii) 3 \sin^{-1}x = \sin^{-1}(3x - 4x^3).$$

$$(viii) 3 \cos^{-1}x = \cos^{-1}(4x^3 - 3x).$$

$$(ix) 3 \tan^{-1}x = \tan^{-1} \frac{3x - x^3}{1 - 3x^2}.$$

$$(x) 2 \tan^{-1}x = \sin^{-1} \frac{2x}{1+x^2} = \cos^{-1} \frac{1-x^2}{1+x^2} = \tan^{-1} \frac{2x}{1-x^2}.$$

V. Complex Arguments.

$$(i) (\cos \theta + i \sin \theta)^n = \cos n\theta + i \sin n\theta.$$

$$(ii) \cos x = 1 - \frac{x^2}{2!} + \frac{x^4}{4!} - \dots + (-1)^n \frac{x^{2n}}{(2n)!} + \dots \text{ to } \infty.$$

$$(iii) \sin x = x - \frac{x^3}{3!} + \dots + (-1)^n \frac{x^{2n+1}}{(2n+1)!} + \dots \text{ to } \infty.$$

$$(iv) \tan^{-1}x = x - \frac{1}{3}x^3 + \frac{1}{5}x^5 - \dots + (-1)^{n-1} \frac{x^{2n-1}}{(2n-1)!} + \dots \text{ to } \infty \quad -1 \leq x \leq 1.$$

$$(v) e^{ix} = \cos x + i \sin x ; e^{-ix} = \cos x - i \sin x.$$

$$(vi) \cos x = \frac{1}{2}(e^{ix} + e^{-ix}) ; \sin x = \frac{1}{2i}(e^{ix} - e^{-ix}).$$

$$(vii) x^n + \frac{1}{x^n} = 2 \cos n\theta ; x^n - \frac{1}{x^n} = 2i \sin n\theta.$$

$$(viii) 2^{n-1} \cos^n \theta = \cos n\theta + n \cos (n-2)\theta + \frac{n(n-1)}{2!} \cos (n-4)\theta + \dots$$

(n being a positive integer)

INTEGRAL CALCULUS

$$(ix) (-1)^{n/2} 2^{n-1} \sin^n \theta$$

$$= \cos n\theta - n \cos (n-2)\theta + \frac{n(n-1)}{2!} \cos (n-4)\theta - \dots$$

(n being an even positive integer)

$$(x) (-1)^{(n-1)/2} 2^{n-1} \sin^n \theta$$

$$= \sin n\theta - n \sin (n-2)\theta + \frac{n(n-1)}{2!} \sin (n-4)\theta - \dots$$

(n being an odd positive integer)

VI. Hyperbolic Functions.

$$(i) \cosh x = \frac{1}{2}(e^x + e^{-x}) ; \sinh x = \frac{1}{2}(e^x - e^{-x}).$$

$$(ii) e^x = \cosh x + \sinh x ; e^{-x} = \cosh x - \sinh x.$$

$$(iii) \cosh^2 x - \sinh^2 x = 1.$$

$$(iv) \operatorname{sech}^2 x + \tanh^2 x = 1.$$

$$(v) \coth^2 x - \operatorname{cosech}^2 x = 1.$$

$$(vi) \sinh 2x = 2 \sinh x \cosh x.$$

$$(vii) \cosh 2x = \cosh^2 x + \sinh^2 x \\ = 2 \cosh^2 x - 1 = 1 + 2 \sinh^2 x.$$

$$(viii) \tanh 2x = \frac{2 \tanh x}{1 + \tanh^2 x}.$$

$$(ix) \sinh (-x) = -\sinh x ; \cosh (-x) = \cosh x.$$

$$(x) \sinh 0 = 0 ; \cosh 0 = 1 ; \tanh 0 = 0.$$

$$(xi) \sinh x = x + \frac{x^3}{3!} + \frac{x^5}{5!} + \dots + \frac{x^{2n+1}}{(2n+1)!} + \dots \text{ to } \infty$$

$$(xii) \cosh x = 1 + \frac{x^2}{2!} + \frac{x^4}{4!} + \dots + \frac{x^{2n}}{(2n)!} + \dots \text{ to } \infty$$

FORMULÆ

$$(xiii) \sinh^{-1}x = \log (x + \sqrt{x^2 + 1}) \text{ for all } x.$$

$$(xiv) \cosh^{-1}x = \log (x + \sqrt{x^2 - 1}) ; (x \geq 1)$$

$$(xv) \tanh^{-1}x = \frac{1}{2} \log \frac{1+x}{1-x} \quad (x^2 < 1)$$

$$(xvi) \operatorname{cosech}^{-1}x = \log \frac{1 + \sqrt{(1+x^2)}}{x} \quad (x \neq 0)$$

$$(xvii) \operatorname{sech}^{-1}x = \log \frac{1 + \sqrt{(1-x^2)}}{x} \quad (0 < x \leq 1),$$

$$(xviii) \operatorname{coth}^{-1}x = \frac{1}{2} \log \frac{x+1}{x-1} \quad (x^2 > 1)$$

VII. Special series.

$$(i) \frac{1}{1^2} + \frac{1}{2^2} + \frac{1}{3^2} + \dots \text{ to } \infty = \frac{\pi^2}{6}.$$

$$(ii) \frac{1}{1^2} + \frac{1}{3^2} + \frac{1}{5^2} + \dots \text{ to } \infty = \frac{\pi^2}{8}.$$

$$(iii) \frac{1}{1^4} + \frac{1}{2^4} + \frac{1}{3^4} + \dots \text{ to } \infty = \frac{\pi^4}{90}.$$

$$(iv) \frac{1}{1^4} + \frac{1}{3^4} + \frac{1}{5^4} + \dots \text{ to } \infty = \frac{\pi^4}{96}.$$

VIII. Logarithm.

$$\log_a m = \log_b m / \log_b a.$$

(B) DIFFERENTIAL CALCULUS

I. Fundamental Properties.

$$(i) \frac{d}{dx} \{u \pm v \pm w + \dots \text{ to } n \text{ terms}\} \\ = \frac{du}{dx} \pm \frac{dv}{dx} \pm \frac{dw}{dx} \pm \dots \text{ to } n \text{ terms.}$$

$$(ii) \frac{d}{dx} (uv) = u \frac{dv}{dx} + v \frac{du}{dx} \quad (iii) \frac{d}{dx} (cu) = c \frac{du}{dx}$$

$$(iv) \frac{d}{dx} \left(\frac{u}{v} \right) = \frac{v \frac{du}{dx} - u \frac{dv}{dx}}{v^2}$$

$$(v) \frac{dy}{dx} = \frac{dy}{dz} \cdot \frac{dz}{dx} \text{ \{where } y = f(z) \text{ and } z = \phi(x)\}.$$

II. Standard differential coefficients.

$$(i) \frac{d}{dx} (c) = 0. \quad (ii) \frac{d}{dx} (x^n) = nx^{n-1}.$$

$$(iii) \frac{d}{dx} \left(\frac{1}{x^n} \right) = -\frac{n}{x^{n+1}}. \quad (iv) \frac{d}{dx} (a^x) = a^x \log_e a.$$

$$(v) \frac{d}{dx} (e^x) = e^x. \quad (vi) \frac{d}{dx} (\log_a x) = \frac{1}{x} \log_a e.$$

$$(vii) \frac{d}{dx} (\log_e x) = \frac{1}{x}. \quad (viii) \frac{d}{dx} (\sin x) = \cos x.$$

$$(ix) \frac{d}{dx} (\cos x) = -\sin x. \quad (x) \frac{d}{dx} (\tan x) = \sec^2 x.$$

$$(xi) \frac{d}{dx} (\cot x) = -\operatorname{cosec}^2 x.$$

$$(xii) \frac{d}{dx} (\operatorname{cosec} x) = -\operatorname{cosec} x \cot x.$$

$$(xiii) \frac{d}{dx} (\sec x) = \sec x \tan x.$$

(C) INTEGRAL CALCULUS

I. Fundamental Properties.

$$(i) \int \{f_1(x) \pm f_2(x) \pm f_3(x) + \dots \text{ to } n \text{ terms}\} dx \\ = \int f_1(x) dx \pm \int f_2(x) dx \pm \int f_3(x) dx + \dots \text{ to } n \text{ terms.}$$

$$(ii) \int cf(x) dx = c \int f(x) dx. \quad f''$$

II. Fundamental Integrals.

$$(i) \int x^n dx = \frac{x^{n+1}}{n+1} \quad (n \neq -1).$$

$$(ii) \int \frac{dx}{x^n} = -\frac{1}{(n-1)x^{n-1}} \quad (n \neq 1).$$

$$(iii) \int dx = x. \quad (iv) \int \frac{dx}{\sqrt{x}} = 2\sqrt{x}.$$

$$(v) \int \frac{dx}{x} = \log |x|. \quad (vi) \int e^{mx} dx = \frac{e^{mx}}{m}.$$

$$(vii) \int e^x dx = e^x. \quad (viii) \int a^x dx = \frac{a^x}{\log_e a} \quad (a > 0)$$

$$(ix) \int \sin mx dx = -\frac{\cos mx}{m}.$$

$$(x) \int \cos x dx = \sin x.$$

$$(xi) \int \cos mx dx = \frac{\sin mx}{m}.$$

$$(xii) \int \sin x dx = -\cos x.$$

$$(xiii) \int \sec^2 x \, dx = \tan x.$$

$$(xiv) \int \operatorname{cosec}^2 x \, dx = -\cot x.$$

$$(xv) \int \sec x \tan x \, dx = \sec x.$$

$$(xvi) \int \operatorname{cosec} x \cot x \, dx = -\operatorname{cosec} x.$$

$$(xvii) \int \sinh x \, dx = \cosh x.$$

$$(xviii) \int \cosh x \, dx = \sinh x.$$

$$(xix) \int \tanh x \, dx = \log (\cosh x).$$

$$(xx) \int \operatorname{coth} x \, dx = \log |(\sinh x)|.$$

$$(xxi) \int \operatorname{cosech} x \, dx = \log |\tanh \frac{1}{2}x|.$$

$$(xxii) \int \operatorname{sech} x \, dx = 2 \tan^{-1} (e^x).$$

$$(xxiii) \int \operatorname{sech}^2 x \, dx = \tanh x.$$

$$(xxiv) \int \operatorname{cosech}^2 x \, dx = -\operatorname{coth} x.$$

III. Standard Integrals.

$$(i) \int \frac{f'(x)}{f(x)} \, dx = \log |f(x)|.$$

$$6. \int \frac{x \, dx}{\sqrt{(x^2 - a^2)(b^2 - x^2)}} \quad (b^2 > a^2).$$

[Put $x^2 - a^2 = z^2$]

$$7. \text{ (i) } \int \frac{dx}{1+x+x^2} \quad \text{(ii) } \int \frac{dr}{4r^2+4r+5}$$

$$8. \text{ (i) } \int \frac{dx}{1+x-x^2} \quad \text{(ii) } \int \frac{dx}{6x^2+7x+2}$$

$$9. \int \frac{x \, dx}{x^4+2x^2+2}$$

$$10. \int \frac{\cos x \, dx}{\sin^2 x + 4 \sin x + 3}$$

$$11. \int \frac{e^x \, dx}{e^{2x} + 2e^x + 5}$$

$$12. \int \frac{dr}{\sqrt{1-r^2}\{1+(\sin^{-1}r)^2\}}$$

$$13. \int \frac{r^2 \, dr}{x^6 - 6x^3 + 5}$$

$$14. \int x \{10 + 7 \log x + (\log x)^2\} \, dx$$

$$15. \text{ (i) } \int \frac{x \, dx}{x^2+2x+1} \quad \text{(ii) } \int \frac{x+1}{3+2x-x^2} \, dx.$$

$$16. \text{ (i) } \int \frac{x+1}{x^2+4x+5} \, dx. \quad \text{(ii) } \int \frac{2x+3}{4x^2+1} \, dx.$$

$$17. \text{ (i) } \int \frac{(4x+3) \, dx}{3x^2+3x+1} \quad \text{(ii) } \int \frac{x \, dx}{2-6x-x^2}$$

$$18. \int \frac{x^2}{x^2-4} \, dx. \quad [C. P. 1935]$$

$$19. \text{ (i) } \int \frac{x^2 + 2x}{x^2 + 2x + 2} dx. \quad \text{(ii) } \int \frac{x^2 - x + 1}{x^2 + x + 1} dx.$$

$$20. \int \frac{x^3 + x^2 + 2x + 1}{x^2 - x + 1} dx.$$

$$21. \int \frac{dx}{\sqrt{x^2 + x - 2}}. \quad [C. P. 1931]$$

$$22. \text{ (i) } \int \frac{dx}{\sqrt{1 - x - x^2}}. \quad \text{(ii) } \int \frac{dx}{\sqrt{3 + 3x + x^2}}$$

$$23. \int \frac{dx}{\sqrt{2x^2 + 3x + 4}}. \quad [P. P. 1932]$$

$$24. \int \frac{dx}{\sqrt{x^2 - 7x + 12}}. \quad [\text{Put } x - 4 = z^2]$$

$$25. \int \frac{dx}{\sqrt{6 + 11x - 10x^2}}.$$

$$26. \int \frac{\cos x \, dx}{\sqrt{5 \sin^2 x - 12 \sin x + 4}}.$$

$$27. \int \frac{dx}{\sqrt{(x - \alpha)(x - \beta)}}.$$

$$28. \text{ (i) } \int \frac{dx}{\sqrt{2ax - x^2}}. \quad \text{(ii) } \int \frac{dx}{\sqrt{2ax + x^2}}.$$

$$29. \text{ (i) } \int \frac{x + b}{\sqrt{x^2 + a^2}} dx. \quad \text{(ii) } \int \frac{2x + 3}{\sqrt{x^2 + x + 1}} dx.$$

$$30. \int \frac{x - 2}{\sqrt{2x^2 - 8x + 5}} dx. \quad [C. P. 1926]$$

$$31. \text{ (i) } \int \frac{(x + 1)}{\sqrt{4 + 8x - 5x^2}} dx. \quad \text{(ii) } \int \frac{(2x - 1) dx}{\sqrt{4x^2 + 4x + 2}}.$$

$$32. \text{ (i) } \int \frac{dx}{(2+x)\sqrt{1+x}} \quad \text{(ii) } \int \frac{dx}{(2x+1)\sqrt{4x+3}}$$

$$33. \int \frac{dx}{\sqrt{\frac{2}{3}x^3 - x^2 + \frac{1}{3}}}$$

$$34. \text{ (i) } \int \sqrt{\frac{x-3}{x-4}} dx. \quad \text{(ii) } \int \sqrt{\frac{2x+1}{3x+2}} dx.$$

$$35. \text{ (i) } \int \frac{dx}{(1-x)\sqrt{x}} \quad \text{(ii) } \int \frac{\sqrt{x} dx}{x-1}$$

[Put $x = z^2$]

$$36. \text{ (i) } \int x \frac{dx}{\sqrt{x^2 \pm a^2}} \quad \text{(ii) } \int \frac{dx}{(1+x)\sqrt{1-x^2}}$$

$$\text{(iii) } \int \frac{dx}{x\sqrt{9x^2+4x+1}} \quad \text{(iv) } \int \frac{dx}{(1+x)\sqrt{1+2x-x^2}}$$

$$\text{(v) } \int x \frac{dx}{\sqrt{x^2+2x-1}} \quad \text{(vi) } \int \frac{dx}{(1+x)\sqrt{1+x-x^2}}$$

$$\text{(vii) } \int \frac{dx}{(x-3)\sqrt{x^2-6x+8}}$$

$$37. \text{ (i) } \int \frac{\sqrt{a^2-x^2}}{x} dx. \quad \text{(ii) } \int \frac{dx}{x+\sqrt{x-1}}$$

$$38. \int \frac{dx}{x\sqrt{1+x^3}} \quad \text{[Put } 1+x^3 = z^2 \text{]}$$

$$39. \text{ (i) } \int \sqrt{\frac{a+x}{x}} dx. \quad \text{(ii) } \int \frac{\sqrt{x-a}}{x} dx.$$

40. If $a < x < b$, show that

$$\int \frac{dx}{(x-a)\sqrt{(x-a)(b-x)}} = \frac{2}{a-b} \sqrt{\frac{b-x}{x-a}}$$

ANSWERS

$$1. \tan^{-1}(x^3). \quad 2. \text{ (i) } \frac{1}{2} \tan^{-1}(x^2). \quad \text{(ii) } \frac{1}{4} \log \frac{x^2-1}{x^2+1}.$$

$$3. \text{ (i) } \tan^{-1}(e^x). \quad \text{(ii) } \frac{1}{4} \sin^{-1}\left(\frac{x}{a}\right)^4.$$

4. (i) $\tan x - \tan^{-1}x$. (ii) $\frac{1}{4} \log \frac{2 - \cos x}{2 + \cos x}$.
5. (i) $\frac{1}{2} \log (x^2 + \sqrt{x^4 + a^4})$. (ii) $\log \{(1 + x^2 + \sqrt{1 + x^2})/x\}$.
6. $\sin^{-1} \sqrt{\frac{x^2 - a^2}{b^2 - a^2}}$. 7. (i) $\frac{2}{\sqrt{3}} \tan^{-1} \frac{2x+1}{\sqrt{3}}$. (ii) $\frac{1}{4} \tan^{-1}(x + \frac{1}{2})$.
8. (i) $\frac{1}{\sqrt{5}} \log \frac{\sqrt{5+2x-1}}{\sqrt{5-2x+1}}$. (ii) $\log \frac{2x+1}{3x+2}$. 9. $\frac{1}{2} \tan^{-1}(x^2 + 1)$.
10. $\frac{1}{2} \log \frac{1 + \sin x}{3 + \sin x}$. 11. $\frac{1}{2} \tan^{-1}\{\frac{1}{2}(e^x + 1)\}$. 12. $\tan^{-1}(\sin^{-1}x)$.
13. $\frac{1}{12} \log \frac{x^3 - 5}{x^3 - 1}$. 14. $\frac{1}{3} \log \frac{2 + \log x}{5 + \log x}$. 15. (i) $\log(x+1) + \frac{1}{x+1}$.
(ii) $-\log(x-3)$. 16. (i) $\frac{1}{2} \log(x^2 + 4x + 5) - \tan^{-1}(x+2)$.
(ii) $\frac{1}{4} \log(4x^2 + 1) + \frac{3}{8} \tan^{-1}(2x)$.
17. (i) $\frac{2}{3} \log(3x^2 + 3x + 1) + \frac{2}{\sqrt{3}} \tan^{-1}\{\sqrt{3}(2x+1)\}$.
(ii) $\frac{-3}{2\sqrt{11}} \log \frac{\sqrt{11} + 3 + x}{\sqrt{11} - 3 - x} - \frac{1}{2} \log(2 - 6x - x^2)$.
18. $x + \log \frac{x-2}{x+2}$. 19. (i) $x - 2 \tan^{-1}(x+1)$.
(ii) $x - \log(x^2 + x + 1) + \frac{2}{\sqrt{3}} \tan^{-1}\left(\frac{2x+1}{\sqrt{3}}\right)$.
20. $\frac{1}{2}x^2 + 2x + \frac{3}{8} \log(x^2 - x + 1) + \frac{1}{\sqrt{3}} \tan^{-1} \frac{2x-1}{\sqrt{3}}$.
21. $2 \log(\sqrt{x+2} + \sqrt{x-1})$. 22. (i) $\sin^{-1} \frac{2x+1}{\sqrt{5}}$.
(ii) $\log(2x+3+2\sqrt{3+3x+x^2})$. 23. $\frac{1}{\sqrt{2}} \log(x + \frac{3}{2} + \sqrt{x^2 + \frac{3}{2}x + 2})$.
24. $2 \log(\sqrt{x-3} + \sqrt{x-4})$. 25. $\sqrt{\frac{2}{5}} \sin^{-1} \sqrt{\frac{10x+4}{19}}$.
26. $-\frac{2}{\sqrt{5}} \log\{\sqrt{2-5 \sin x} + \sqrt{5(2-\sin x)}\}$.

27. $2 \log (\sqrt{x-a} + \sqrt{x-\beta})$. 28. (i) $\sin^{-1} \left(\frac{x-a}{a} \right)$.
 (ii) $\log (x+a + \sqrt{x^2+2ax})$. 29. (i) $\sqrt{x^2+a^2} + b \log (x + \sqrt{x^2+a^2})$.
 (ii) $2 \sqrt{x^2+x+1} + 2 \log (x + \frac{1}{2} + \sqrt{x^2+x+1})$.
30. $\frac{1}{2} \sqrt{2x^2-8x+5}$. 31. (i) $\frac{9}{5\sqrt{5}} \sin^{-1} \left(\frac{5x-4}{6} \right) - \frac{1}{5} \sqrt{4+8x-5x^2}$.
 (ii) $\frac{1}{2} \sqrt{4x^2+4x+2} - \log (2x+1 + \sqrt{4x^2+4x+2})$.
32. (i) $2 \tan^{-1} \sqrt{1+x}$. (ii) $\frac{1}{2} \log \left(\frac{\sqrt{4x+3}-1}{\sqrt{4x+3+1}} \right)$.
33. $\log \frac{\sqrt{2x+1}-\sqrt{3}}{\sqrt{2x+1}+\sqrt{3}}$. 34. (i) $\sqrt{(x-3)(x-4)} + \log (\sqrt{x-3} + \sqrt{x-4})$.
 (ii) $\frac{1}{6} [2 \sqrt{(2x+1)(3x+2)} - \sqrt{3} \log (\sqrt{3} \sqrt{2x+1} + \sqrt{2} \sqrt{3x+2})]$.
35. (i) $\log \frac{1+\sqrt{x}}{1-\sqrt{x}}$. (ii) $2 \sqrt{x} + \log \frac{\sqrt{x}-1}{\sqrt{x}+1}$.
36. (i) $\frac{1}{2a} \log \frac{\sqrt{x^2+a^2-a}}{\sqrt{x^2+a^2+a}} ; \frac{1}{a} \sec^{-1} \frac{x}{a}$. (ii) $-\sqrt{\frac{1-x}{1+x}}$.
 (iii) $\log x - \log (1+2x + \sqrt{9x^2+4x+1})$.
 (iv) $\frac{1}{\sqrt{2}} \sin^{-1} \left(\frac{x\sqrt{2}}{1+x} \right)$. (v) $\sin^{-1} \left(\frac{x-1}{x\sqrt{2}} \right)$.
 (vi) $\sin^{-1} \left(\frac{3x+1}{(1+x)\sqrt{5}} \right)$. (vii) $\sec^{-1} (x-3)$.
37. (i) $\sqrt{a^2-x^2} + a \log \frac{a-\sqrt{a^2-x^2}}{x}$.
 (ii) $\log (x + \sqrt{x-1}) - \frac{2}{\sqrt{3}} \tan^{-1} \left(\frac{2\sqrt{x-1}+1}{\sqrt{3}} \right)$.
38. $\frac{2}{3} \log (\sqrt{1+x^3}-1) - \log x$. 39. (i) $a \log (\sqrt{x} + \sqrt{x+a}) + \sqrt{x(x+a)}$.
 (ii) $2 \sqrt{x-a} - 2 \sqrt{a} \tan^{-1} \left(\sqrt{\frac{x-a}{a}} \right)$.
-

CHAPTER III

INTEGRATION BY PARTS

3.1. Integration of a product 'by parts'.

We know from Differential Calculus that if u and v_1 are two differentiable functions of x ,

$$\frac{d}{dx} (uv_1) = \frac{du}{dx} v_1 + u \frac{dv_1}{dx}.$$

∴ integrating both sides with respect to x , we have

$$uv_1 = \int \left(\frac{du}{dx} \cdot v_1 \right) dx + \int \left(u \frac{dv_1}{dx} \right) dx,$$

or,
$$\int \left(u \frac{dv_1}{dx} \right) dx = uv_1 - \int \left(\frac{du}{dx} \cdot v_1 \right) dx.$$

Suppose $\frac{dv_1}{dx} = v$, then $v_1 = \int v dx$.

Hence, the above result can be written as

$$\int (uv) dx = u \int v dx - \int \left\{ \frac{du}{dx} \int v dx \right\} dx.$$

The above formula for the integration of a product of two functions is referred to as *integration by parts*.

It states that

the integral of the product of two functions

= 1st function (unchanged) × integral of 2nd

- integral of [diff. coeff. of 1st × integral of 2nd].

3.2. Illustrative Examples.

Ex. 1. Integrate $\int xe^x dx$.

$$\begin{aligned} I &= x \int e^x dx - \left\{ \frac{dx}{dx} \int e^x dx \right\} dx \\ &= xe^x - \int 1 \cdot e^x dx \\ &= xe^x - e^x. \end{aligned}$$

Note. In the above integral, instead of taking x as the first function and e^x as the second, if we take e^x as the first function and x as the second, then applying the rule for integration by parts, we get

$$\int (e^x x) dx = e^x \cdot \frac{1}{2}x^2 - \int e^x \cdot \frac{1}{2}x^2 dx.$$

The integral $\frac{1}{2} \int e^x x^2 dx$ on the right side is more complicated than the one we started with, for it involves x^2 instead of x .

Thus, while applying the rule for integration by parts to the product of two functions, care should be taken to choose properly the first function i.e., the function not to be integrated.

A little practice and experience will enable the student to make the right choice.

Ex. 2. Integrate $\int \log x dx$. [C. P. 1928]

$$\begin{aligned} I &= \int \log x \cdot 1 dx. \\ &= \log x \int dx - \int \left\{ \frac{d}{dx} (\log x) \cdot \int dx \right\} dx \\ &= \log x \cdot x - \int \frac{1}{x} \cdot x dx \\ &= x \log x - \int dx \\ &= x \log x - x. \end{aligned}$$

Ex. 3. Integrate $\int \tan^{-1} x \, dx$. [C. P. 1929, '36]

$$\begin{aligned}
 I &= \int \tan^{-1} x \cdot 1 \, dx \\
 &= \tan^{-1} x \cdot \int dx - \int \left\{ \frac{d}{dx} (\tan^{-1} x) \right\} \int dx \, dx \\
 &= \tan^{-1} x \cdot x - \int \frac{1}{1+x^2} \cdot x \, dx \\
 &= x \tan^{-1} x - \frac{1}{2} \int \frac{2x}{1+x^2} \, dx \\
 &= x \tan^{-1} x - \frac{1}{2} \log (1+x^2). \quad [\text{By Ex. 5, Art. 2'2}]
 \end{aligned}$$

Note. Very often an *integral involving a single logarithmic function or a single inverse circular function can be evaluated by the application of the rule for integration by parts*, by considering the integral as the product of the given function and unity, and taking the given function as the first function and unity as the second.

This principle is illustrated in Exs. 2 and 3 above and Ex. 4 below.

Ex. 4. Integrate $\int \log (x + \sqrt{x^2 + a^2}) \, dx$.

$$\begin{aligned}
 I &= \int \log (x + \sqrt{x^2 + a^2}) \cdot 1 \, dx \\
 &= \log (x + \sqrt{x^2 + a^2}) \int dx - \int \left[\frac{d}{dx} \left\{ \log (x + \sqrt{x^2 + a^2}) \right\} \right] \int dx \, dx \\
 &= \log (x + \sqrt{x^2 + a^2}) \cdot x - \int \frac{1}{\sqrt{x^2 + a^2}} \cdot x \, dx \\
 &= x \log (x + \sqrt{x^2 + a^2}) - \int \frac{x \, dx}{\sqrt{x^2 + a^2}}.
 \end{aligned}$$

To evaluate $\int \frac{x \, dx}{\sqrt{x^2 + a^2}}$, put $x^2 + a^2 = z^2$, so that $x \, dx = z \, dz$.

$$\therefore \int \frac{x \, dx}{\sqrt{x^2 + a^2}} = \int \frac{z \, dz}{z} = \int dz = z = \sqrt{x^2 + a^2}.$$

$$\therefore I = x \log (x + \sqrt{x^2 + a^2}) - \sqrt{x^2 + a^2}.$$

Ex. 5. Integrate $\int x^3 e^x dx$.

$$\begin{aligned} I &= x^3 e^x - 3 \int x^2 e^x dx, \text{ integrating by parts} \\ &= x^3 e^x - 3 [x^2 e^x - 2 \int x e^x dx], \text{ integrating by parts again} \\ &= x^3 e^x - 3 [x^2 e^x - 2 \{x e^x - \int e^x dx\}] \\ &= x^3 e^x - 3 [x^2 e^x - 2 \{x e^x - e^x\}] \\ &= x^3 e^x - 3x^2 e^x + 6x e^x - 6e^x \\ &= (x^3 - 3x^2 + 6x - 6) e^x. \end{aligned}$$

3.3. Standard Integrals.

$$\begin{aligned} \text{(A)} \quad \int e^{ax} \cos bx \, dx &= \frac{e^{ax} (a \cos bx + b \sin bx)}{a^2 + b^2} \\ &= \frac{e^{ax}}{\sqrt{a^2 + b^2}} \cos \left(bx - \tan^{-1} \frac{b}{a} \right). \end{aligned}$$

$$\begin{aligned} \text{(B)} \quad \int e^{ax} \sin bx \, dx &= \frac{e^{ax} (a \sin bx - b \cos bx)}{a^2 + b^2} \\ &= \frac{e^{ax}}{\sqrt{a^2 + b^2}} \sin \left(bx - \tan^{-1} \frac{b}{a} \right). \end{aligned}$$

(Here $a \neq 0$.)

Proof. Integrating by parts,

$$\begin{aligned} \int e^{ax} \cos bx \, dx &= e^{ax} \cdot \frac{\sin bx}{b} - \int \left(a e^{ax} \cdot \frac{\sin bx}{b} \right) dx \\ &= \frac{e^{ax} \sin bx}{b} - \frac{a}{b} \int e^{ax} \sin bx \, dx \end{aligned}$$

Now, integrating by parts the right-side of this integral

$$\begin{aligned}
 &= \frac{e^{ax} \sin bx}{b} - \frac{a}{b} \left\{ e^{ax} \frac{-\cos bx}{b} - \int a e^{ax} \cdot \left(\frac{-\cos bx}{b} \right) dx \right\} \\
 &= \frac{e^{ax} \sin bx}{b} + \frac{a}{b^2} e^{ax} \cos bx - \frac{a^2}{b^2} \int e^{ax} \cos bx dx.
 \end{aligned}$$

∴ transposing,

$$\left(1 + \frac{a^2}{b^2} \right) \int e^{ax} \cos bx dx = \frac{e^{ax} (a \cos bx + b \sin bx)}{b^2}$$

Now, dividing both sides by $1 + \frac{a^2}{b^2}$ i.e., $\frac{a^2 + b^2}{b^2}$, we get

$$\int e^{ax} \cos bx dx = \frac{e^{ax} (a \cos bx + b \sin bx)}{a^2 + b^2}.$$

Again, putting $a = r \cos \alpha$, $b = r \sin \alpha$, so that $r = \sqrt{a^2 + b^2}$ and $\alpha = \tan^{-1} \frac{b}{a}$ on the right side of this integral,

we have, the right side

$$= \frac{e^{ax} r \cos (bx - \alpha)}{a^2 + b^2} = \frac{e^{ax}}{\sqrt{a^2 + b^2}} \cos \left(bx - \tan^{-1} \frac{b}{a} \right).$$

Integral (B) can be evaluated exactly in the same way.

Note 1. The above integrals can also be obtained thus :

Denoting the integrals (A) and (B) by I_1 , and I_2 , and integrating each by parts, we shall get

$$aI_1 - bI_2 = e^{ax} \cos bx$$

$$\text{and, } bI_1 + aI_2 = e^{ax} \sin bx$$

from which I_1 and I_2 can be easily determined.

Note 2. Exactly in the same way the integrals $\int e^{ax} \cos (bx+c) dx$ and $\int e^{ax} \sin (bx+c) dx$ can be evaluated.

3.4. Standard Integrals.

$$(C) \int \sqrt{x^2+a^2} \, dx = \frac{x\sqrt{x^2+a^2}}{2} + \frac{a^2}{2} \log |(x + \sqrt{x^2+a^2})|$$

$$(D) \int \sqrt{x^2-a^2} \, dx = \frac{x\sqrt{x^2-a^2}}{2} - \frac{a^2}{2} \log |(x + \sqrt{x^2-a^2})|$$

$$(E) \int \sqrt{a^2-x^2} \, dx = \frac{x\sqrt{a^2-x^2}}{2} + \frac{a^2}{2} \sin^{-1} \frac{x}{a}.$$

Proof.

(C) Integrating by parts,

$$\begin{aligned} \int \sqrt{x^2+a^2} \, dx &= \sqrt{x^2+a^2} \cdot x - \int \frac{2x}{\sqrt{x^2+a^2}} \cdot x \, dx \\ &= x\sqrt{x^2+a^2} - \int \frac{x^2}{\sqrt{x^2+a^2}} \, dx \quad \dots \quad (i) \end{aligned}$$

$$\begin{aligned} \text{Also, } \int \sqrt{x^2+a^2} \, dx &= \int \frac{x^2+a^2}{\sqrt{x^2+a^2}} \, dx \\ &= \int \frac{x^2}{\sqrt{x^2+a^2}} \, dx + a^2 \int \frac{dx}{\sqrt{x^2+a^2}} \quad \dots \quad (ii) \end{aligned}$$

Adding (i) and (ii) and dividing by 2,

$$\begin{aligned} \int \sqrt{x^2+a^2} \, dx &= \frac{x\sqrt{x^2+a^2}}{2} + \frac{a^2}{2} \int \frac{dx}{\sqrt{x^2+a^2}} \\ &= \frac{x\sqrt{x^2+a^2}}{2} + \frac{a^2}{2} \log |(x + \sqrt{x^2+a^2})|. \end{aligned}$$

[By Art. 2.3 (D)]

$$\begin{aligned}
\text{(D)} \quad & \int \sqrt{x^2 - a^2} \, dx \\
&= \sqrt{x^2 - a^2} \cdot x - \int \frac{2x}{2\sqrt{x^2 - a^2}} \cdot x \, dx \\
&= x \sqrt{x^2 - a^2} - \int \frac{x^2}{\sqrt{x^2 - a^2}} \, dx \\
&= x \sqrt{x^2 - a^2} - \int \frac{(x^2 - a^2) + a^2}{\sqrt{x^2 - a^2}} \, dx \\
&= x \sqrt{x^2 - a^2} - \int \frac{x^2 - a^2}{\sqrt{x^2 - a^2}} \, dx - a^2 \int \frac{dx}{\sqrt{x^2 - a^2}} \\
&= x \sqrt{x^2 - a^2} - \int \sqrt{x^2 - a^2} \, dx - a^2 \int \frac{dx}{\sqrt{x^2 - a^2}}.
\end{aligned}$$

Now, transposing $\int \sqrt{x^2 - a^2} \, dx$ to the left side and dividing by 2,

$$\int \sqrt{x^2 - a^2} \, dx = \frac{x \sqrt{x^2 - a^2}}{2} - \frac{a^2}{2} \log |(x + \sqrt{x^2 - a^2})|.$$

[*By Art. 23(D)*]

Note. The integral (C) can be evaluated by the method of evaluating the integral (D), and the integral (D) can also be evaluated by the method of evaluating the integral (C).

(E) Although this integral can be easily evaluated by either of the methods employed in evaluating integrals (C) and (D) above, yet another method, the method of substitution may be adopted in evaluating this integral.

Putting $x = a \sin \theta$, so that $dx = a \cos \theta d\theta$, we get

$$\begin{aligned} \int \sqrt{a^2 - x^2} dx &= a^2 \int \cos^2 \theta d\theta \\ &= a^2 \cdot \frac{1}{2} \int (1 + \cos 2\theta) d\theta \\ &= \frac{1}{2} a^2 [\int \cos 2\theta d\theta + \int d\theta] \\ &= \frac{1}{2} a^2 [\frac{1}{2} \sin 2\theta + \theta] \\ &= \frac{1}{2} a^2 \cdot \sin \theta \cos \theta + \frac{1}{2} a^2 \theta \\ &= \frac{1}{2} a^2 \cdot \frac{x}{a} \sqrt{1 - \frac{x^2}{a^2}} + \frac{1}{2} a^2 \sin^{-1} \frac{x}{a} \\ &= \frac{x \sqrt{a^2 - x^2}}{2} + \frac{a^2}{2} \sin^{-1} \frac{x}{a}. \end{aligned}$$

Note. The integrals (C) and (D) can also be evaluated by putting $x = a \sinh z$ and $x = a \cosh z$ respectively.

3'5. $\int \sqrt{ax^2 + bx + c} dx. \quad (a \neq 0)$

To integrate this, express $ax^2 + bx + c$ as the sum or difference of two squares, as the case may be; that is express $ax^2 + bx + c$ in either of the forms $a\{(x + l)^2 \pm m^2\}$ or, $a\{m^2 - (x + l)^2\}$ and then substitute z for $x + l$. Now the integral reduces to one of the forms (C), (D) or (E) discussed above. This is illustrated in Ex. 3 of Art. 3'8.

3'6. $\int (px + q) \sqrt{ax^2 + bx + c} dx. \quad (a \neq 0)$

To integrate this, put $px + q \equiv \frac{p}{2a} (2ax + b) + \left(q - \frac{bp}{2a}\right)$; then the integral reduces to the sum of two integrals, the first of which can be immediately integrated by putting $z = ax^2 + bx + c$, and the second is of the form of the previous Article. This is illustrated in Ex. 4 of Art. 3'8.

$$3.7. \int e^x \{f(x) + f'(x)\} dx.$$

Integrating by parts $\int e^x f(x) dx$, we have

$$\int e^x f(x) dx = \int f(x) e^x dx = f(x) e^x - \int f'(x) e^x dx.$$

\therefore transposing, $\int e^x \{f(x) + f'(x)\} dx = e^x f(x)$.

Alternatively, we may integrate by parts $\int e^x f'(x) dx$, and derive the same result.

Note. $\int e^x \phi(x) dx$, when $\phi(x)$ can be broken up as the sum of two functions of x , such that one is the differential coefficient of the other, can be easily integrated as above.

3.8. Illustrative Examples.

Ex. 1. Integrate $\int e^{2x} \sin 3x \cos x dx$.

$$\begin{aligned} I &= \frac{1}{2} \int e^{2x} \cdot 2 \sin 3x \cos x dx \\ &= \frac{1}{2} \int e^{2x} (\sin 4x + \sin 2x) dx \\ &= \frac{1}{2} [\int e^{2x} \sin 4x dx + \int e^{2x} \sin 2x dx] \\ &= \frac{1}{2} \left[\frac{e^{2x}}{\sqrt{20}} \sin (4x - \tan^{-1} 2) + \frac{e^{2x}}{\sqrt{8}} \sin (2x - \tan^{-1} 1) \right] \\ &= \frac{e^{2x}}{2} \left[\frac{1}{\sqrt{20}} \sin (4x - \tan^{-1} 2) + \frac{1}{\sqrt{8}} \sin \left(2x - \frac{\pi}{4} \right) \right]. \end{aligned}$$

[See Art. 3.3(B)]

Ex. 2. Integrate $\int \frac{\cos^3 x}{e^{3x}} dx$.

$$\begin{aligned} I &= \int e^{-3x} \cos^3 x dx = \frac{1}{4} \int e^{-3x} (\cos 3x + 3 \cos x) dx \\ &= \frac{1}{4} [\int e^{-3x} \cos 3x dx + 3 \int e^{-3x} \cos x dx] \\ &= \frac{1}{4} \left[\frac{e^{-3x}}{18} \cdot (-3 \cos 3x + 3 \sin 3x) + 3 \cdot \frac{e^{-3x}}{10} (-3 \cos x + \sin x) \right] \\ &= \frac{e^{-3x}}{8} \left\{ \frac{1}{3} (\sin 3x - \cos 3x) + \frac{3}{5} (\sin x - 3 \cos x) \right\}. \end{aligned}$$

Ex. 3. Integrate $\int \sqrt{4+8x-5x^2} dx$.

$$\begin{aligned} I &= \int \sqrt{5\left(\frac{4}{5} + \frac{8}{5}x - x^2\right)} dx \\ &= \sqrt{5} \int \sqrt{\frac{4}{5} - \left(\frac{4}{5} - \frac{8}{5}x + x^2\right)} dx \\ &= \sqrt{5} \int \sqrt{\left(\frac{4}{5}\right)^2 - \left(x - \frac{4}{5}\right)^2} dx \\ &= \sqrt{5} \int \sqrt{a^2 - z^2} dz, \quad \left(\text{putting } z = x - \frac{4}{5} \text{ and } a = \frac{4}{5}\right) \\ &= \sqrt{5} \left[\frac{z \sqrt{a^2 - z^2}}{2} + \frac{a^2}{2} \sin^{-1} \frac{z}{a} \right] \quad [\text{By Art. 3.4 (E)}] \\ &= \sqrt{5} \left[\frac{(5x-4) \sqrt{4+8x-5x^2}}{10 \sqrt{5}} + \frac{18}{25} \sin^{-1} \left(\frac{5x-4}{6} \right) \right] \end{aligned}$$

on restoring the values of a and z and simplifying,

$$= \frac{1}{10} (5x-4) \sqrt{4+8x-5x^2} + \frac{18}{5 \sqrt{5}} \sin^{-1} \left(\frac{5x-4}{6} \right).$$

Ex. 4. Integrate $\int (3x-2) \sqrt{x^2-x+1} dx$.

Since $3x-2 = \frac{3}{2}(2x-1) - \frac{1}{2}$,

$$\therefore I = \frac{3}{2} \int (2x-1) \sqrt{x^2-x+1} dx - \frac{1}{2} \int \sqrt{x^2-x+1} dx.$$

To evaluate the 1st integral,

put $z = x^2 - x + 1$; $\therefore dz = (2x-1) dx$.

$$\therefore \text{1st integral} = \int \sqrt{z} dz = \frac{2}{3} z^{\frac{3}{2}} = \frac{2}{3} (x^2 - x + 1)^{\frac{3}{2}}.$$

$$\begin{aligned} \text{2nd integral} &= \int \sqrt{\left(x - \frac{1}{2}\right)^2 + \frac{3}{4}} dx \\ &= \int \sqrt{z^2 + a^2} dz, \text{ putting } z = x - \frac{1}{2} \text{ and } a^2 = \frac{3}{4}, \\ &= \frac{z \sqrt{z^2 + a^2}}{2} + \frac{a^2}{2} \log (z + \sqrt{z^2 + a^2}) \\ &= \frac{1}{2} (2x-1) \sqrt{x^2-x+1} + \frac{3}{8} \log (x - \frac{1}{2} + \sqrt{x^2-x+1}). \end{aligned}$$

$$\begin{aligned} \therefore I &= (x^2 - x + 1)^{\frac{3}{2}} - \frac{1}{8} (2x-1) \sqrt{x^2-x+1} \\ &\quad - \frac{3}{8} \log |(x - \frac{1}{2} + \sqrt{x^2-x+1})|. \end{aligned}$$

Ex. 5. Integrate $\int \frac{x^2+x+1}{\sqrt{x^2+2x+3}} dx$. [C. P. 1929]

$$\begin{aligned} I &= \int \frac{(x^2+2x+3)-(x+2)}{\sqrt{x^2+2x+3}} dx \\ &= \int \frac{x^2+2x+3}{\sqrt{x^2+2x+3}} dx - \int \frac{x+2}{\sqrt{x^2+2x+3}} dx \\ &= \int \sqrt{x^2+2x+3} dx - \int \frac{\frac{1}{2}(2x+2)+1}{\sqrt{x^2+2x+3}} dx \\ &= \int \sqrt{(x+1)^2+2} dx - \frac{1}{2} \int \frac{(2x+2) dx}{\sqrt{x^2+2x+3}} - \int \frac{dx}{\sqrt{(x+1)^2+2}} \end{aligned}$$

Denoting the right-side integrals by I_1, I_2, I_3 ,

$$\begin{aligned} I_1 - I_3 &= \int \sqrt{z^2+a^2} dz - \int \frac{dz}{\sqrt{z^2+a^2}}, \text{ (where } z=x+1, a^2=2 \text{)} \\ &= \frac{1}{2} z \sqrt{z^2+a^2} + \frac{1}{2} a^2 \log (z + \sqrt{z^2+a^2}) - \log (z + \sqrt{z^2+a^2}) \\ &= \frac{1}{2} (x+1) \sqrt{x^2+2x+3}, \text{ on restoring the values of } z \text{ and } a^2. \end{aligned}$$

Putting $x^2+2x+3=z$, so that $(2x+2) dx=dz$,

$$I_2 = \int \frac{dz}{\sqrt{z}} = 2 \sqrt{z} = 2 \sqrt{x^2+2x+3}.$$

$$\begin{aligned} \therefore I &= \frac{1}{2} (x+1) \sqrt{x^2+2x+3} - \sqrt{x^2+2x+3} \\ &= \frac{1}{2} (x-1) \sqrt{x^2+2x+3}. \end{aligned}$$

Ex. 6. Integrate $\int \frac{x e^x}{(x+1)^2} dx$. [C. P. 1930, '33, '37, '48]

$$I = \int \frac{(x+1) e^x - e^x}{(x+1)^2} dx = \int \frac{e^x}{x+1} dx - \int \frac{e^x}{(x+1)^2} dx.$$

Integrating by parts, the first integral

$$\int \frac{1}{x+1} \cdot e^x dx = \frac{1}{x+1} \cdot e^x + \int \frac{1}{(x+1)^2} e^x dx.$$

$$\therefore I = \frac{e^x}{x+1}.$$

Ex. 7. Prove that (if $a \neq b$),

$$(i) \int e^{ax} \sinh bx \, dx = \frac{e^{ax}}{a^2 - b^2} (a \sinh bx - b \cosh bx).$$

$$(ii) \int e^{ax} \cosh bx \, dx = \frac{e^{ax}}{a^2 - b^2} (a \cosh bx - b \sinh bx).$$

(i) Integrating by parts,

$$\begin{aligned} I &= \frac{e^{ax} \cosh bx}{b} - \int a e^{ax} \frac{\cosh bx}{b} \, dx \\ &= \frac{e^{ax} \cosh bx}{b} - \frac{a}{b} \int e^{ax} \cosh bx \, dx. \end{aligned} \quad \dots (1)$$

Again integrating by parts,

$$\begin{aligned} \int e^{ax} \cosh bx \, dx &= \frac{e^{ax} \sinh bx}{b} - \frac{a}{b} \int e^{ax} \sinh bx \, dx \\ &= \frac{e^{ax} \sinh bx}{b} - \frac{a}{b} I. \end{aligned} \quad \dots (2)$$

From (1) and (2),

$$I = \frac{e^{ax} \cosh bx}{b} - \frac{a}{b^2} e^{ax} \sinh bx + \frac{a^2}{b^2} I.$$

Transposing,

$$\left(1 - \frac{a^2}{b^2}\right) I = \frac{e^{ax}}{b^2} (b \cosh bx - a \sinh bx).$$

$$\therefore I = \frac{e^{ax}}{a^2 - b^2} (a \sinh bx - b \cosh bx).$$

(ii) This integral can be evaluated in the same way.

Alternatively we can use the exponential values of $\sinh x$ and $\cosh x$ to evaluate these integrals.

$$\begin{aligned} \text{Thus, } \int e^{ax} \sinh bx \, dx &= \int e^{ax} \cdot \frac{1}{2} (e^{bx} - e^{-bx}) \, dx \\ &= \frac{1}{2} \int \{e^{(a+b)x} - e^{(a-b)x}\} \, dx \\ &= \frac{1}{2} \left\{ \frac{e^{(a+b)x}}{a+b} - \frac{e^{(a-b)x}}{a-b} \right\} \\ &= \frac{1}{2} e^{ax} \left\{ \frac{e^{bx}}{a+b} - \frac{e^{-bx}}{a-b} \right\} \\ &= \frac{1}{2} e^{ax} \left\{ \frac{(a-b)e^{bx} - (a+b)e^{-bx}}{a^2 - b^2} \right\} \\ &= \frac{e^{ax}}{a^2 - b^2} [a \cdot \frac{1}{2} (e^{bx} - e^{-bx}) - b \cdot \frac{1}{2} (e^{bx} + e^{-bx})] \\ &= \frac{e^{ax}}{a^2 - b^2} [a \sinh bx - b \cosh bx]. \end{aligned}$$

EXAMPLES III

1. Integrate the following with respect to x :—

- | | | |
|-----------------------------|-------------------------------------|--------------------------------------|
| (i) $x \sin x$. | (ii) $x^2 \cos x$. | (iii) xe^{ax} . |
| (iv) $x^n \log x$. | (v) $x^2 e^x$. | (vi) $x \sec^2 x$. |
| (vii) $\sin^{-1} x$. | (viii) $\cos^{-1} x$. | (ix) $\operatorname{cosec}^{-1} x$. |
| (x) $\sec^{-1} x$. | (xi) $\cot^{-1} x$. | (xii) $\cos^{-1} (1/x)$. |
| (xiii) $x \sin^{-1} x$. | (xiv) $x^2 \tan^{-1} x$. | (xv) $x \cos nx$. |
| (xvi) $(\log x)^2$. | (xvii) $x \log x$. | (xviii) $\sin^{-1} \sqrt{x}$. |
| (xix) $\log (1+x)^{1+x}$ | (xx) $\frac{\log (x+1)}{(x+1)^2}$. | |
| (xxi) $\log (1+2x^2+x^4)$. | (xxii) $\log (x^2+5x+6)$. | |
| (xxiii) $x^3 \cos 2x$. | (xxiv) $x^3 (\log x)^2$. | |

Integrate :—

2. (i) $\int x \sin^2 x \, dx$. (ii) $\int x \sin x \cos x \, dx$.
3. (i) $\int \log (x - \sqrt{x^2 - 1}) \, dx$. (ii) $\int \log (x^2 - x + 1) \, dx$.
4. (i) $\int \left\{ \frac{1}{\log x} - \frac{1}{(\log x)^2} \right\} dx$. (ii) $\int \frac{x}{1 + \cos x} \, dx$.
5. (i) $\int \sin x \log (\sec x + \tan x) \, dx$.
- (ii) $\int \cos x \log (\operatorname{cosec} x + \cot x) \, dx$.
6. (i) $\int \cos 2x \log (1 + \tan x) \, dx$.
- (ii) $\int \operatorname{cosec}^2 x \log \sec x \, dx$.
7. (i) $\int \sin^{-1} (3x - 4x^3) \, dx$. (ii) $\int (\sin^{-1} x)^3 \, dx$.

8. (i) $\int \cos^{-1} \frac{1-x^2}{1+x^2} dx.$ (ii) $\int \tan^{-1} \frac{2x}{1-x^2} dx.$
9. (i) $\int \sin^{-1} \frac{2x}{1+x^2} dx.$ (ii) $\int \tan^{-1} \frac{3x-x^3}{1-3x^2} dx.$
10. (i) $\int \frac{\cos^{-1} x}{x^3} dx.$ (ii) $\int \tan^{-1} \sqrt{\frac{1-x}{1+x}} dx.$
11. (i) $\int \frac{x \sin^{-1} x}{\sqrt{1-x^2}} dx.$ (ii) $\int \frac{\sin^{-1} x}{(1-x^2)^{\frac{3}{2}}} dx.$
12. (i) $\int e^x \sin x dx.$ (ii) $\int e^x \cos x dx.$
- (iii) $\int 2^x \sin x dx.$ (iv) $\int 3^x \cos 3x dx.$
- (v) $\int e^x \sinh x dx.$ (vi) $\int e^x \cosh x dx.$
13. (i) $\int e^x \sin^2 x dx.$ (ii) $\int e^x \sin x \sin 2x dx.$
14. $\int \frac{e^{m \tan^{-1} x}}{(1+x^2)^2} dx.$ [Put $\tan^{-1} x = z$] [C. P. 1929]
15. (i) $\int \frac{x + \sin x}{1 + \cos x} dx.$ (ii) $\int \frac{\log(x+1)}{\sqrt{x+1}} dx.$
16. $\int \tan^{-1} \left(\frac{1 + \cos x}{\sin x} \right) dx.$
17. $\int \sin^{-1} \sqrt{\frac{x}{x+a}} dx.$ [Put $x = a \tan^2 \theta$]
18. $\int e^x (\cos x + \sin x) dx.$
19. $\int \frac{e^x}{x} (1 + x \log x) dx.$

$$20. \text{ (i) } \int e^x (\tan x - \log \cos x) dx.$$

$$\text{ (ii) } \int e^x \sec x (1 + \tan x) dx.$$

$$21. \text{ (i) } \int e^x \frac{x^2 + 1}{(x + 1)^2} dx. \quad \text{ (ii) } \int e^x \frac{(1 - x)^2}{(1 + x^2)^2} dx.$$

$$\left[\text{ (i) Write } \frac{x^2 + 1}{(x + 1)^2} = \frac{x^2 - 1 + 2}{(x + 1)^2} = \frac{x - 1}{x + 1} + \frac{2}{(x + 1)^2} \right]$$

$$\text{ (iii) } \int e^x \frac{x - 1}{(x + 1)^2} dx.$$

$$22. \text{ (i) } \int e^x \frac{1 + \sin x}{1 + \cos x} dx. \quad \text{ (ii) } \int e^x \frac{1 - \sin x}{1 - \cos x} dx.$$

$$\text{ (iii) } \int e^x \frac{2 - \sin 2x}{1 - \cos 2x} dx. \quad \text{ (iv) } \int e^x \frac{2 + \sin 2x}{1 + \cos 2x} dx.$$

$$23. \int \sqrt{25 - 9x^2} dx.$$

$$24. \text{ (i) } \int \sqrt{5 - 2x + x^2} dx. \quad \text{ (ii) } \int \sqrt{10 - 4x + 4x^2} dx.$$

$$25. \text{ (i) } \int \sqrt{18x - 65 - x^2} dx. \quad \text{ (ii) } \int \sqrt{4 - 3x - 2x^2} dx.$$

$$26. \int \sqrt{5x^2 + 8x + 4} dx.$$

$$27. \int \frac{dx}{x + \sqrt{x^2 - 1}}$$

$$28. \int \sqrt{2ax - x^2} dx.$$

$$29. \int \sqrt{(x - a)(\beta - x)} dx. \quad [\text{Put } x = a \cos^2 \theta + \beta \sin^2 \theta]$$

$$30. \text{ (i) } \int (x-1) \sqrt{x^2-1} \, dx. \quad \text{(ii) } \int (a+b) \sqrt{x^2+a^2} \, dx.$$

$$31. \text{ (i) } \int (x-1) \sqrt{x^2-x+1} \, dx.$$

$$\text{(ii) } \int (x+2) \sqrt{2x^2+2x+1} \, dx.$$

$$32. \text{ (i) } \int \frac{x^2+x+1}{\sqrt{1-x^2}} \, dx. \quad \text{(ii) } \int \frac{x^2+2x+3}{\sqrt{x^2+x+1}} \, dx.$$

$$33. \int \frac{x^3+2x^2+x-7}{\sqrt{x^2+2x+3}} \, dx.$$

$$34. \text{ (i) } \int \sqrt{\frac{a+x}{a-x}} \, dx. \quad \text{(ii) } \int x \sqrt{\frac{a-x}{a+x}} \, dx.$$

$$35. \int \frac{(x+1) \sqrt{x+2}}{\sqrt{x-2}} \, dx. \quad [P. P. 1934]$$

$$36. \text{ If } u = \int e^{ax} \cos bx \, dx, \, v = \int e^{ax} \sin bx \, dx,$$

prove that

$$\text{(i) } \tan^{-1} \frac{v}{u} + \tan^{-1} \frac{b}{a} = bx.$$

$$\text{(ii) } (a^2 + b^2)(u^2 + v^2) = e^{2ax}.$$

ANSWERS

$$1. \text{ (i) } -x \cos x + \sin x.$$

$$\text{(ii) } (x^2-2) \sin x + 2x \cos x.$$

$$\text{(iii) } \frac{e^{ax}}{a^2} (ax-1).$$

$$\text{(iv) } \frac{x^{n+1}}{n+1} \left[\log x - \frac{1}{n+1} \right].$$

$$\text{(v) } e^x (x^2 - 2x + 2).$$

$$\text{(vi) } x \tan x + \log \cos x.$$

$$\text{(vii) } x \sin^{-1} x + \sqrt{1-x^2}.$$

$$\text{(viii) } x \cos^{-1} x - \sqrt{1-x^2}.$$

(ix) $x \operatorname{cosec}^{-1} x + \log (x + \sqrt{x^2 - 1})$. (x) $x \sec^{-1} x - \log (x + \sqrt{x^2 - 1})$.

(xi) $x \cot^{-1} x + \frac{1}{2} \log (1 + x^2)$. (xii) $x \sec^{-1} x - \log (x + \sqrt{x^2 - 1})$.

(xiii) $\frac{1}{2} x^2 \sin^{-1} x - \frac{1}{4} \sin^{-1} x + \frac{1}{4} x \sqrt{1 - x^2}$.

(xiv) $\frac{1}{3} x^3 \tan^{-1} x - \frac{1}{6} x^2 + \frac{1}{6} \log (1 + x^2)$.

(xv) $\frac{x \sin nx}{n} + \frac{\cos nx}{n^2}$. (xvi) $x (\log x)^2 - 2x \log x + 2x$.

(xvii) $\frac{1}{4} x^2 (2 \log x - 1)$. (xviii) $(x - \frac{1}{2}) \sin^{-1} \sqrt{x} + \frac{1}{2} \sqrt{x(1-x)}$.

(xix) $\frac{1}{2} (1+x)^2 \log (1+x) - \frac{1}{4} x (x+2)$. (xx) $-(1+x)^{-1} [\log (1+x) + 1]$.

(xxi) $2 \{x \log (1+x^2) - 2x + 2 \tan^{-1} x\}$.

(xxii) $(x+2) \log (x+2) + (x+3) \log (x+3) - 2x$.

(xxiii) $\frac{1}{4} x (2x^2 - 3) \sin 2x + \frac{3}{8} (2x^2 - 1) \cos 2x$.

(xxiv) $\frac{1}{4} x^4 \{(\log x)^2 - \frac{1}{2} \log x + \frac{1}{8}\}$.

2. (i) $\frac{1}{8} (2x^2 - 2x \sin 2x - \cos 2x)$. (ii) $-\frac{1}{4} x \cos 2x + \frac{1}{8} \sin 2x$.

3. (i) $x \log (x - \sqrt{x^2 - 1}) + \sqrt{x^2 - 1}$.

(ii) $(x - \frac{1}{2}) \log (x^2 - x + 1) - 2x + \sqrt{3} \tan^{-1} \frac{2x-1}{\sqrt{3}}$.

4. (i) $x (\log x)^{-1}$. (ii) $x \tan \frac{1}{2} x + 2 \log \cos \frac{1}{2} x$.

5. (i) $x - \cos x \log (\sec x + \tan x)$. (ii) $\sin x \log (\operatorname{cosec} x + \cot x) + x$.

6. (i) $\sin x \cos x \log (1 + \tan x) - \frac{1}{2} x + \frac{1}{2} \log (\sin x + \cos x)$.

(ii) $-\cot x \log (\sec x) + x$.

7. (i) $3 (x \sin^{-1} x + \sqrt{1 - x^2})$.

(ii) $x (\sin^{-1} x)^3 + 3 \sqrt{1 - x^2} (\sin^{-1} x)^2 - 6 (x \sin^{-1} x + \sqrt{1 - x^2})$.

8. (i) $2x \tan^{-1} x - \log (1 + x^2)$. (ii) Same as (i).

9. (i) Same as 8 (i). (ii) $3x \tan^{-1} x - \frac{3}{2} \log (1 + x^2)$.

10. (i) $\frac{x \sqrt{(1-x^2)} - \cos^{-1} x}{2x^3}$. (ii) $\frac{1}{2} [x \cos^{-1} x - \sqrt{(1-x^2)}]$.

11. (i) $x - \sqrt{1-x^2} \sin^{-1} x$. (ii) $\frac{x \sin^{-1} x}{\sqrt{1-x^2}} + \frac{1}{2} \log (1-x^2)$.

12. (i) $\frac{1}{2}e^x (\sin x - \cos x)$. (ii) $\frac{1}{2}e^x (\sin x + \cos x)$.
 (iii) $\frac{2^x \sin \{x - \cot^{-1} (\log 2)\}}{\sqrt{1 + (\log 2)^2}}$.
 (iv) $\frac{3^x \{3 \sin 3x + (\log 3) \cos 3x\}}{9 + (\log 3)^2}$.
 (v) $\frac{1}{4} (\cosh 2x + \sinh 2x) - \frac{1}{2}x$. (vi) $\frac{1}{4} (\cosh 2x + \sinh 2x) + \frac{1}{2}x$.
13. (i) $\frac{1}{2}e^x \{1 - \frac{1}{2} (\cos 2x + 2 \sin 2x)\}$.
 (ii) $\frac{1}{4}e^x \{(\cos x + \sin x) - \frac{1}{6} (\cos 3x + 3 \sin 3x)\}$.
14. $\frac{e^m \tan^{-1} x}{2} \left[\frac{1}{m} + \frac{1}{m^2 + 4} \left\{ m \frac{1 - x^2}{1 + x^2} + \frac{4x}{1 + x^2} \right\} \right]$.
15. (i) $x \tan \frac{1}{2}x$. (ii) $2 \sqrt{x+1} \log (x+1) - 4 \sqrt{x+1}$.
16. $\frac{1}{2}\pi x - \frac{1}{2}x^2$. 17. $(x+a) \tan^{-1} \left(\frac{x}{a} \right)^{\frac{1}{2}} - \sqrt{ax}$.
18. $e^x \sin x$. 19. $e^x \log x$.
20. (i) $e^x \log \sec x$. (ii) $e^x \sec x$.
21. (i) $e^x \frac{x-1}{x+1}$. (ii) $\frac{e^x}{1+x^2}$. (iii) $\frac{e^x}{(1+x)^2}$.
22. (i) $e^x \tan \frac{1}{2}x$. (ii) $-e^x \cot \frac{1}{2}x$. (iii) $-e^x \cot x$.
 (iv) $e^x \tan x$. 23. $\frac{x}{2} \sqrt{25 - 9x^2} + \frac{25}{6} \sin^{-1} \frac{3x}{5}$.
24. (i) $\frac{1}{2} (x-1) \sqrt{5 - 2x + x^2} + 2 \log (x-1 + \sqrt{5 - 2x + x^2})$.
 (ii) $\frac{1}{4} (2x-1) \sqrt{10 - 4x + 4x^2} + \frac{9}{4} \log \{(2x-1) + \sqrt{10 - 4x + 4x^2}\}$.
25. (i) $\frac{1}{2} (x-9) \sqrt{18x - 65 - x^2} + 8 \sin^{-1} \frac{1}{4} (x-9)$.
 (ii) $\frac{1}{8} (4x+3) \sqrt{4 - 3x - 2x^2} + \frac{41}{32} \sqrt{2} \sin^{-1} \frac{4x+3}{\sqrt{41}}$.
26. $\frac{1}{10} (5x+4) \sqrt{5x^2 + 8x + 4} + \frac{2}{5} \sqrt{5} \log \{(5x+4) + \sqrt{5(5x^2 + 8x + 4)}\}$.
27. $\frac{1}{2} \{x(x - \sqrt{x^2 - 1}) + \log (x + \sqrt{x^2 - 1})\}$.
28. $\frac{1}{2} (x-a) \sqrt{2ax - x^2} + \frac{1}{2} a^2 \sin^{-1} \left(\frac{x-a}{a} \right)$.
29. $\frac{1}{4} \left[(2x-a-\beta) \sqrt{(x-a)(\beta-x)} + (\beta-a)^2 \sin^{-1} \sqrt{\frac{x-a}{\beta-a}} \right]$.

30. (i) $\frac{1}{3} (x^2 - 1)^{\frac{3}{2}} - \frac{1}{2} x \sqrt{x^2 - 1} + \frac{1}{2} \log (x + \sqrt{x^2 - 1})$.
 (ii) $\frac{1}{3} (x^2 + a^2)^{\frac{3}{2}} + \frac{1}{2} bx \sqrt{x^2 + a^2} + \frac{1}{2} a^2 b \log (x + \sqrt{x^2 + a^2})$.
31. (i) $\frac{1}{3} (x^2 - x + 1)^{\frac{3}{2}} - \frac{1}{3} (2x - 1) \sqrt{x^2 - x + 1} - \frac{1}{18} \log (x - \frac{1}{2} + \sqrt{x^2 - x + 1})$.
 (ii) $\frac{1}{3} (2x^2 + 2x + 1)^{\frac{3}{2}} + \frac{2}{3} (2x + 1) \sqrt{2x^2 + 2x + 1}$
 $+ \frac{3}{8\sqrt{2}} \log \{(2x + 1) + \sqrt{2(2x^2 + 2x + 1)}\}$.
32. (i) $\frac{2}{3} \sin^{-1} x - \frac{1}{2} (x + 2) \sqrt{1 - x^2}$.
 (ii) $\frac{1}{4} (2x + 5) \sqrt{x^2 + x + 1} + \frac{1}{8} \log \{(x + \frac{1}{2}) + \sqrt{x^2 + x + 1}\}$.
33. $\frac{1}{3} (x^2 + 2x + 3)^{\frac{3}{2}} - \frac{1}{2} (x + 5) \sqrt{x^2 + 2x + 3} - 6 \log (x + 1 + \sqrt{x^2 + 2x + 3})$.
34. (i) $a \sin^{-1} \frac{x}{a} - \sqrt{a^2 - x^2}$. (ii) $(\frac{1}{2}x - a) \sqrt{a^2 - x^2} - \frac{1}{2}a^2 \sin^{-1} \frac{x}{a}$.
35. $\frac{1}{2} (x + 6) \sqrt{x^2 - 4} + 4 \log (x + \sqrt{x^2 - 4})$.

CHAPTER IV

SPECIAL TRIGONOMETRIC FUNCTIONS

4.1. Standard Integrals.

$$(A) \int \operatorname{cosec} x \, dx = \log \left| \tan \frac{x}{2} \right|.$$

$$\begin{aligned} \text{Proof. } \int \operatorname{cosec} x \, dx &= \int \frac{dx}{\sin x} = \int \frac{dx}{2 \sin \frac{1}{2}x \cos \frac{1}{2}x} \\ &= \int \frac{\frac{1}{2} \sec^2 \frac{1}{2}x}{\tan \frac{1}{2}x} dx \end{aligned}$$

$$\begin{aligned} & \text{(on multiplying numerator and denominator by } \sec^2 \frac{1}{2}x \text{)} \\ & = \log \left| \tan \frac{1}{2}x \right| \end{aligned}$$

since, numerator is the diff. coeff. of denominator.

$$\begin{aligned} (B) \int \sec x \, dx &= \log \left| \tan \left(\frac{\pi}{4} + \frac{x}{2} \right) \right| \\ &= \log |(\sec x + \tan x)|. \end{aligned}$$

$$\begin{aligned} \text{Proof. } \int \sec x \, dx &= \int \frac{dx}{\cos x} = \int \frac{dx}{\sin \left(\frac{1}{2}\pi + x \right)} \\ &= \int \frac{dx}{2 \sin \left(\frac{1}{2}\pi + \frac{1}{2}x \right) \cos \left(\frac{1}{2}\pi + \frac{1}{2}x \right)} \\ &= \int \frac{\frac{1}{2} \sec^2 \left(\frac{1}{2}\pi + \frac{1}{2}x \right) dx}{\tan \left(\frac{1}{2}\pi + \frac{1}{2}x \right)} \\ &= \log \left| \tan \left(\frac{1}{2}\pi + \frac{1}{2}x \right) \right| \text{ as in (A).} \end{aligned}$$

Note. *Alternative Methods :*

$$\int \operatorname{cosec} x \, dx = \int \frac{\operatorname{cosec} x (\operatorname{cosec} x - \cot x)}{\operatorname{cosec} x - \cot x} \, dx = \log |(\operatorname{cosec} x - \cot x)|$$

$$\begin{aligned} \int \operatorname{cosec} x \, dx &= \int \frac{dx}{\sin x} = \int \frac{\sin x}{\sin^2 x} \, dx \\ &= - \int \frac{d(\cos x)}{1 - \cos^2 x} = - \int \frac{dz}{1 - z^2}, \text{ where } z = \cos x \end{aligned}$$

$$\frac{1}{2} \log \frac{1-z}{1+z} = \frac{1}{2} \log \left| \frac{1 - \cos x}{1 + \cos x} \right|$$

$$\int \sec x \, dx = \int \frac{\sec x (\sec x + \tan x)}{\sec x + \tan x} \, dx = \log |\sec x + \tan x|,$$

since the numerator is the derivative of the denominator.

$$\begin{aligned} \int \sec x \, dx &= \int \frac{\cos x}{\cos^2 x} \, dx = \int \frac{d(\sin x)}{1 - \sin^2 x} \\ &= \int \frac{dz}{1 - z^2} = \frac{1}{2} \log \frac{1+z}{1-z}, \text{ where } z = \sin x \end{aligned}$$

$$= \frac{1}{2} \log \frac{1 + \sin x}{1 - \sin x}$$

$$\begin{aligned} \int \sec x \, dx &= \int \frac{dx}{\cos x} = \int \frac{dx}{\cos^2 \frac{1}{2}x - \sin^2 \frac{1}{2}x} \\ &= \int \frac{\sec^2 \frac{1}{2}x \, dx}{1 - \tan^2 \frac{1}{2}x} = 2 \int \frac{dz}{1 - z^2}, \text{ where } z = \tan \frac{1}{2}x \end{aligned}$$

$$= \log \frac{1+z}{1-z} = \log \left| \frac{1 + \tan \frac{1}{2}x}{1 - \tan \frac{1}{2}x} \right|.$$

It should be noted that the different forms in which the integrals of $\operatorname{cosec} x$ and of $\sec x$ are obtained by different methods can be easily shown to be identical by elementary trigonometry.

Thus,

$$\begin{aligned} \frac{1}{2} \log \left| \frac{1 - \cos x}{1 + \cos x} \right| &= \frac{1}{2} \log \left| \frac{2 \sin^2 \frac{1}{2}x}{2 \cos^2 \frac{1}{2}x} \right| = \frac{1}{2} \log |\tan^2 \frac{1}{2}x| \\ &= \log |\tan \frac{1}{2}x|; \text{ etc.} \end{aligned}$$

$$1.2. \int \frac{dx}{a + b \cos x}$$

The given integral

$$\begin{aligned} &= \int \frac{dx}{a (\cos^2 \frac{1}{2}x + \sin^2 \frac{1}{2}x) + b (\cos^2 \frac{1}{2}x - \sin^2 \frac{1}{2}x)} \\ &= \int \frac{\sec^2 \frac{1}{2}x dx}{(a+b) + (a-b) \tan^2 \frac{1}{2}x} \end{aligned}$$

(on multiplying the numerator and denominator by $\sec^2 \frac{1}{2}x$).

Case I. $a > b$.

$$\text{Put } \sqrt{a-b} \tan \frac{1}{2}x = z; \quad \therefore \frac{1}{2} \sqrt{a-b} \sec^2 \frac{1}{2}x dx = dz.$$

The given integral now becomes

$$\begin{aligned} &\frac{2}{\sqrt{a-b}} \int \frac{dz}{(a+b) + z^2} \\ &= \frac{2}{\sqrt{a^2 - b^2}} \tan^{-1} \frac{z}{\sqrt{a+b}} \quad [\text{See (A), Art. 2'3.}] \\ &= \frac{2}{\sqrt{a^2 - b^2}} \tan^{-1} \left(\sqrt{\frac{a-b}{a+b}} \tan \frac{x}{2} \right) \\ \text{i.e.,} \quad &= \frac{1}{\sqrt{a^2 - b^2}} \tan^{-1} \left(\frac{b + a \cos x}{a + b \cos x} \right). \end{aligned}$$

Case II. $a < b$.

$$\text{Put } \sqrt{b-a} \tan \frac{1}{2}x = z; \quad \therefore \frac{1}{2} \sqrt{b-a} \sec^2 \frac{1}{2}x dx = dz.$$

As before, the required integral becomes

$$\begin{aligned} & \frac{2}{\sqrt{b-a}} \int \frac{dz}{(a+b)-z^2} \\ &= \frac{2}{\sqrt{b-a}} \cdot \frac{1}{2\sqrt{b+a}} \log \left\{ \frac{\sqrt{b+a+z}}{\sqrt{b+a-z}} \right\} \\ & \qquad \qquad \qquad [\text{ See (C), Art. 2'3 }] \\ &= \frac{1}{\sqrt{b^2-a^2}} \log \left\{ \frac{\sqrt{b+a} + \sqrt{b-a} \tan \frac{1}{2}x}{\sqrt{b+a} - \sqrt{b-a} \tan \frac{1}{2}x} \right\} \end{aligned}$$

Note 1. Here it is assumed that $a > 0$, $b > 0$; if $a < 0$, $b > 0$ or, $a > 0$, $b < 0$, or, $a < 0$, $b < 0$, then the integral can be evaluated exactly in the same way.

Note 2. (i) If $b = a$, the integrand reduces to $\frac{1}{2a} \sec^2 \frac{1}{2}x$, the integral of which is $\frac{1}{a} \tan \frac{1}{2}x$.

(ii) If $b = -a$, the integrand reduces to $\frac{1}{2a} \operatorname{cosec}^2$, the integral of which is $-\frac{1}{a} \cot \frac{1}{2}x$.

Note 3. By an exactly similar process, the integral $\int \frac{dx}{a+b \sin x}$ or more generally $\int \frac{dx}{a+b \cos x+c \sin x}$ can be evaluated by breaking $\sin x$ and $\cos x$ in terms of $\frac{1}{2}x$ and then multiplying the numerator and the denominator of the integrand by $\sec^2 \frac{1}{2}x$ and substituting z for $\tan \frac{1}{2}x$. This is illustrated in Examples 3 and 4 of Art. 4'8 below.

In fact *any rational function of $\sin x$, $\cos x$* can be easily integrated by expressing $\sin x$ and $\cos x$ in terms of $\tan \frac{1}{2}x$, i.e., by writing

$$\sin x = \frac{2 \tan \frac{1}{2}x}{1 + \tan^2 \frac{1}{2}x} \quad \text{and} \quad \cos x = \frac{1 - \tan^2 \frac{1}{2}x}{1 + \tan^2 \frac{1}{2}x}$$

and then putting $\tan \frac{1}{2}x = z$.

Similar integrals involving *hyperbolic functions* can be evaluated by an exactly similar process.

4.3. Positive integral powers of sine and cosine.**(A) Odd positive index.**

Any odd positive power of a sine and cosine can be integrated immediately by substituting $\cos x = z$ and $\sin x = z$ respectively as shown below.

$$\begin{aligned} \text{Ex. (i)} \quad \int \sin^3 x \, dx &= \int \sin^2 x \sin x \, dx = - \int (1 - \cos^2 x) \, d(\cos x) \\ &= - \int (1 - z^2) \, dz \quad [\text{Putting } z \text{ for } \cos x] \\ &= - \left(z - \frac{1}{3} z^3 \right) = - \left(\cos x - \frac{1}{3} \cos^3 x \right). \end{aligned}$$

$$\begin{aligned} \text{Ex. (ii)} \quad \int \cos^5 x \, dx &= \int \cos^4 x \cos x \, dx = \int (1 - \sin^2 x)^2 \, d(\sin x) \\ &= \int (1 - z^2)^2 \, dz \quad [\text{Putting } z \text{ for } \sin x] \\ &= \int (1 - 2z^2 + z^4) \, dz = z - \frac{2}{3} z^3 + \frac{1}{5} z^5 \\ &= \sin x - \frac{2}{3} \sin^3 x + \frac{1}{5} \sin^5 x. \end{aligned}$$

(B) Even positive index.

In order to integrate any even positive power of sine and cosine, we should first express it in terms of multiple angles by means of trigonometry and then integrate it.

$$\begin{aligned} \text{Ex. (iii)} \quad \text{Integrate } \int \cos^4 x \, dx. \\ \cos^4 x &= \left\{ \frac{1}{2} (1 + \cos 2x) \right\}^2 = \frac{1}{4} \{ 1 + 2 \cos 2x + \cos^2 2x \} \\ &= \frac{1}{4} \left[1 + 2 \cos 2x + \frac{1}{2} (1 + \cos 4x) \right] \\ &= \frac{3}{8} + \frac{1}{2} \cos 2x + \frac{1}{8} \cos 4x. \\ \therefore \int \cos^4 x \, dx &= \int \left(\frac{3}{8} + \frac{1}{2} \cos 2x + \frac{1}{8} \cos 4x \right) dx \\ &= \frac{3}{8} x + \frac{1}{4} \sin 2x + \frac{1}{32} \sin 4x. \end{aligned}$$

Note 1. It should be noted that when the index is large, it would be more convenient to express the powers of sines or cosines of angles in terms of multiple angles by the use of De Moivre's Theorem, as shown below.

Ex. (iv) Integrate $\int \sin^8 x \, dx$.

$$\begin{array}{l} \text{Let } \cos x + i \sin x = y, \\ \text{then, } \cos x - i \sin x = \frac{1}{y} \end{array} \quad \left. \begin{array}{l} \therefore \cos nx + i \sin nx = y^n \\ \cos nx - i \sin nx = \frac{1}{y^n} \end{array} \right\}$$

$$\begin{array}{ll} \therefore y + \frac{1}{y} = 2 \cos x & y^n + \frac{1}{y^n} = 2 \cos nx \\ y - \frac{1}{y} = 2i \sin x & y^n - \frac{1}{y^n} = 2i \sin nx. \end{array}$$

$$\begin{aligned} \therefore 2^8 i^8 \sin^8 x &= \left(y - \frac{1}{y} \right)^8 \\ &= \left(y^8 + \frac{1}{y^8} \right) - 8 \left(y^6 + \frac{1}{y^6} \right) + 28 \left(y^4 + \frac{1}{y^4} \right) - 56 \left(y^2 + \frac{1}{y^2} \right) + 70 \\ &= 2 \cos 8x - 8 \cdot 2 \cos 6x + 28 \cdot 2 \cos 4x - 56 \cdot 2 \cos 2x + 70. \end{aligned}$$

$$\therefore \sin^8 x = 2^{-7} (\cos 8x - 8 \cos 6x + 28 \cos 4x - 56 \cos 2x + 35).$$

$$\begin{aligned} \therefore \int \sin^8 x \, dx &= 2^{-7} \int (\cos 8x - 8 \cos 6x + 28 \cos 4x - 56 \cos 2x + 35) \, dx \\ &= \frac{1}{2^7} \left[\frac{\sin 8x}{8} - \frac{8 \sin 6x}{6} + 28 \frac{\sin 4x}{4} - 56 \frac{\sin 2x}{2} + 35x \right] \\ &= \frac{1}{2^7} \left[\frac{1}{8} \sin 8x - \frac{4}{3} \sin 6x + 7 \sin 4x - 28 \sin 2x + 35x \right]. \end{aligned}$$

Note 2. When the index is an odd positive integer, then also we can first express the function in terms of multiple angles and then integrate it; but in this case, it is better to adopt the method shown above in (A).

$$\text{Thus, } \int \sin^3 x \, dx = \int \frac{1}{2} (3 \sin x - \sin 3x) \, dx = -\frac{3}{2} \cos x + \frac{1}{12} \cos 3x.$$

4.4. Products of positive integral powers of sine and cosine.

Any product of the form $\sin^p x \cos^q x$ admits of immediate integration as in Sec A, Art. 4.3, whenever *either* p or q is a positive odd integer, whatever the other may be. But when *both* p and q are positive even indices, we may first express the function as the sum of a series of sines or cosines of multiples of x as in Sec. B, Art. 4.3, and then integrate it.

Ex. (i) Integrate $\int \sin^2 x \cos^5 x \, dx$.

$$\begin{aligned} I &= \int \sin^2 x \cos^4 x \cos x \, dx \\ &= \int \sin^2 x (1 - \sin^2 x)^2 \, d(\sin x) \\ &= \int z^2 (1 - z^2)^2 \, dz, \quad [\text{putting } z = \sin x] \\ &= \int (z^2 - 2z^4 + z^6) \, dz \\ &= \frac{1}{3} z^3 - \frac{2}{5} z^5 + \frac{1}{7} z^7 \\ &= \frac{1}{3} \sin^3 x - \frac{2}{5} \sin^5 x + \frac{1}{7} \sin^7 x. \end{aligned}$$

Ex. (ii) Integrate $\int \sin^4 x \cos^2 x \, dx$.

$$\left. \begin{array}{l} \text{Let } \cos x + i \sin x = y; \\ \text{then, } \cos x - i \sin x = \frac{1}{y} \end{array} \right\} \quad \therefore \begin{array}{l} \cos nx + i \sin nx = y^n \\ \cos nx - i \sin nx = \frac{1}{y^n}. \end{array}$$

$$\therefore y + \frac{1}{y} = 2 \cos x \qquad y^n + \frac{1}{y^n} = 2 \cos nx.$$

$$y - \frac{1}{y} = 2i \sin nx \qquad y^n - \frac{1}{y^n} = 2i \sin nx.$$

$$\begin{aligned} \therefore 2^0 i^4 \sin^4 x \cos^2 x &= \left(y - \frac{1}{y}\right)^4 \left(y + \frac{1}{y}\right)^2 = \left(y - \frac{1}{y}\right)^2 \left(y^2 - \frac{1}{y^2}\right)^2 \\ &= \left(y^2 - 2 + \frac{1}{y^2}\right) \left(y^4 - 2 + \frac{1}{y^4}\right) \\ &= \left(y^6 + \frac{1}{y^6}\right) - 2 \left(y^4 + \frac{1}{y^4}\right) - \left(y^2 + \frac{1}{y^2}\right) + 4 \\ &= 2 \cos 6x - 2 \cdot 2 \cos 4x - 2 \cos 2x + 4. \end{aligned}$$

$$\therefore \sin^4 x \cos^2 x = 2^{-5} [\cos 6x - 2 \cos 4x - \cos 2x + 2].$$

$$\begin{aligned} \therefore \int \sin^4 x \cos^2 x \, dx &= 2^{-5} \int (\cos 6x - 2 \cos 4x - \cos 2x + 2) \, dx \\ &= \frac{1}{2^5} \left[\frac{\sin 6x}{6} - \frac{2 \sin 4x}{4} - \frac{\sin 2x}{2} + 2x \right] \end{aligned}$$

Note. The expression $\sin^p x \cos^q x$ also admits of immediate integration in terms of $\tan x$ or $\cot x$ if $p+q$ be a negative even integer, whatever p and q may be. In this case, the best substitution is $\tan x$ or $\cot x = z$. For other cases of $\sin^p x \cos^q x$, a reduction formula is generally required. See § 8'14–8'17.

Ex. (iii) Integrate $\int \frac{\sin^2 x}{\cos^6 x} dx$.

Here, $p+q=2-6=-4$; \therefore put $\tan x = z$, then $\sec^2 x dx = dz$.

Now,
$$\begin{aligned} I &= \int \tan^2 x \cdot \sec^4 x dx \\ &= \int z^2 (1+z^2) dz = \frac{1}{3}z^3 + \frac{1}{5}z^5 \\ &= \frac{1}{3} \tan^3 x + \frac{1}{5} \tan^5 x. \end{aligned}$$

Ex. (iv) Integrate $\int \frac{dx}{\sin^{\frac{1}{2}} x \cos^{\frac{7}{2}} x}$.

Here, $p+q = -\frac{1}{2} - \frac{7}{2} = -4$; \therefore put $\tan x = z$, then $\sec^2 x dx = dz$.

Now,
$$\begin{aligned} I &= \int \frac{\sec^4 x dx}{\tan^{\frac{1}{2}} x} = \int \frac{1+z^2}{z^{\frac{1}{2}}} dz \\ &= \int (z^{-\frac{1}{2}} + z^{\frac{3}{2}}) dz = 2z^{\frac{1}{2}} + \frac{2}{5}z^{\frac{5}{2}} \\ &= 2 \tan^{\frac{1}{2}} x + \frac{2}{5} \tan^{\frac{5}{2}} x. \end{aligned}$$

4'5. Integral powers of tangent and cotangent.

Any integral powers of tangent and cotangent can be readily integrated. Thus,

(i)
$$\begin{aligned} \int \tan^3 x dx &= \int \tan x \cdot \tan^2 x dx = \int \tan x (\sec^2 x - 1) dx \\ &= \int \tan x d(\tan x) - \int \tan x dx = \frac{1}{2} \tan^2 x - \log \sec x. \end{aligned}$$

(ii)
$$\begin{aligned} \int \cot^4 x dx &= \int \cot^2 x (\operatorname{cosec}^2 x - 1) dx \\ &= \int \cot^2 x \operatorname{cosec}^2 x dx - \int \cot^2 x dx \\ &= -\int \cot^2 x d(\cot x) = \int (\operatorname{cosec}^2 x - 1) dx \\ &= -\frac{1}{2} \cot^3 x + \cot x + x. \end{aligned}$$

4.6. Positive integral powers of secant and cosecant.**(A) Even positive index.**

Even positive powers of secant or cosecant admit of immediate integration in terms of $\tan x$ or $\cot x$. Thus,

$$\begin{aligned} \text{(i) } \int \sec^4 x \, dx &= \int (1 + \tan^2 x) \sec^2 x \, dx \\ &= \int \sec^2 x \, dx + \int \tan^2 x \, d(\tan x) \\ &= \tan x + \frac{1}{3} \tan^3 x. \end{aligned}$$

$$\begin{aligned} \text{(ii) } \int \operatorname{cosec}^6 x \, dx &= \int \operatorname{cosec}^4 x \cdot \operatorname{cosec}^2 x \, dx \\ &= \int (1 + \cot^2 x)^2 \operatorname{cosec}^2 x \, dx \\ &= - \int (1 + 2 \cot^2 x + \cot^4 x) \cdot d(\cot x) \\ &= - \cot x - \frac{2}{3} \cot^3 x - \frac{1}{5} \cot^5 x. \end{aligned}$$

(B) Odd positive index.

Odd positive powers of secant and cosecant are to be integrated by the application of the rule of integration by parts.

$$\begin{aligned} \text{(iii) } \int \sec^3 x \, dx &= \int \sec x \cdot \sec^2 x \, dx = \sec x \tan x - \int \sec x \tan^2 x \, dx \\ &= \sec x \tan x - \int \sec x (\sec^2 x - 1) \, dx \\ &= \sec x \tan x + \int \sec x \, dx - \int \sec^3 x \, dx. \end{aligned}$$

\therefore transposing $\int \sec^3 x \, dx$ to the left side, writing the value of $\int \sec x \, dx$, and dividing by 2, we get

$$\int \sec^3 x \, dx = \frac{1}{2} \sec x \tan x + \frac{1}{2} \log \tan \left(\frac{\pi}{4} + \frac{x}{2} \right).$$

$$\begin{aligned} \text{(iv) } \int \sec^5 x \, dx &= \int \sec^3 x \sec^2 x \, dx \\ &= \sec^3 x \tan x - \int 3 \sec^3 x \tan^2 x \, dx \\ &= \sec^3 x \tan x - 3 \int \sec^3 x (\sec^2 x - 1) \, dx \\ &= \sec^3 x \tan x + 3 \int \sec^3 x \, dx - 3 \int \sec^5 x \, dx. \end{aligned}$$

Now, transposing $3 \int \sec^5 x \, dx$ and writing the value of $\int \sec^3 x \, dx$, we get ultimately,

$$\int \sec^5 x \, dx = \frac{\tan x \sec^3 x}{4} + \frac{3}{4} \cdot \frac{\tan x \sec x}{2} + \frac{3}{4} \cdot \frac{1}{2} \log \tan \left(\frac{\pi}{4} + \frac{x}{2} \right).$$

$$\begin{aligned}
 \text{(v)} \int \operatorname{cosec}^3 x \, dx &= \int \operatorname{cosec} x \operatorname{cosec}^2 x \, dx \\
 &= -\operatorname{cosec} x \cot x - \int \operatorname{cosec} x \cot^2 x \, dx \\
 &= -\operatorname{cosec} x \cot x - \int \operatorname{cosec} x (\operatorname{cosec}^2 x - 1) \, dx \\
 &= -\operatorname{cosec} x \cot x + \int \operatorname{cosec} x \, dx - \int \operatorname{cosec}^3 x \, dx.
 \end{aligned}$$

\therefore transposing $\int \operatorname{cosec}^3 x \, dx$ and writing the value of $\int \operatorname{cosec} x \, dx$,
 $\int \operatorname{cosec}^3 x \, dx = -\frac{1}{2} \operatorname{cosec} x \cot x + \frac{1}{2} \log \tan \frac{1}{2} x.$

4.7. Hyperbolic Functions.

$$\text{(i)} \int \sinh x \, dx = \int \frac{1}{2}(e^x - e^{-x}) \, dx = \frac{1}{2}(e^x + e^{-x}) = \cosh x.$$

$$\text{(ii)} \int \cosh x \, dx = \int \frac{1}{2}(e^x + e^{-x}) \, dx = \frac{1}{2}(e^x - e^{-x}) = \sinh x.$$

$$\text{(iii)} \int \tanh x \, dx = \int \frac{\sinh x}{\cosh x} \, dx = \log (\cosh x).$$

$$\text{(iv)} \int \coth x \, dx = \int \frac{\cosh x}{\sinh x} \, dx = \log |(\sinh x)|.$$

$$\begin{aligned}
 \text{(v)} \int \operatorname{cosech} x \, dx &= \int \frac{dx}{\sinh x} = 2 \int \frac{dx}{e^x - e^{-x}} \\
 &= 2 \int \frac{e^x \, dx}{e^{2x} - 1} \\
 &= \int \left(\frac{1}{e^x - 1} - \frac{1}{e^x + 1} \right) d(e^x) \\
 &= \log \left| \frac{e^x - 1}{e^x + 1} \right| \\
 &= \log |\tanh \frac{1}{2} x|.
 \end{aligned}$$

[on dividing the numerator and denominator by $e^{\frac{1}{2}x}$]

$$\begin{aligned}
 \text{(vi)} \int \operatorname{sech} x \, dx &= \int \frac{dx}{\cosh x} = 2 \int \frac{e^x}{1 + e^{2x}} \, dx \\
 &= 2 \int \frac{d(e^x)}{1 + e^{2x}} = 2 \tan^{-1}(e^x) \\
 &= 2 \tan^{-1}(\cosh x + \sinh x).
 \end{aligned}$$

Otherwise :

$$\begin{aligned} \int \operatorname{sech} x \, dx &= \int \frac{dx}{\cosh x} = \int \frac{dx}{\cosh^2 \frac{1}{2}x + \sinh^2 \frac{1}{2}x} \\ &= 2 \int \frac{\frac{1}{2} \operatorname{sech}^2 \frac{1}{2}x}{1 + \tanh^2 \frac{1}{2}x} dx \\ &= 2 \int \frac{dz}{1+z^2} \quad [\text{on putting } z = \tanh \frac{1}{2}x] \\ &= 2 \tan^{-1} z = 2 \tan^{-1} (\tanh \frac{1}{2}x). \end{aligned}$$

$$(vii) \int \operatorname{sech}^2 x \, dx = \tanh x.$$

$$(viii) \int \operatorname{cosech}^2 x \, dx = -\operatorname{coth} x.$$

$$(ix) \int \operatorname{sech} x \tanh x \, dx = -\operatorname{sech} x.$$

$$(x) \int \operatorname{cosech} x \operatorname{coth} x \, dx = -\operatorname{cosech} x.$$

4.8. Illustrative Examples.

Ex. 1. Integrate $\int \frac{dx}{a \sin x + b \cos x}$. [C. P. 1928, '30]

Put $a = r \cos \theta$, $b = r \sin \theta$, then $a \sin x + b \cos x = r \sin (x + \theta)$.

Here $r = \sqrt{a^2 + b^2}$ and $\theta = \tan^{-1} \frac{b}{a}$.

$$\begin{aligned} \therefore I &= \int \frac{dx}{r \sin (x + \theta)} = \frac{1}{r} \int \operatorname{cosec} (x + \theta) \, dx \\ &= \frac{1}{r} \int \operatorname{cosec} z \, dz, \text{ where } z = x + \theta \\ &= \frac{1}{r} \log \tan \frac{z}{2} = \frac{1}{r} \log \tan \frac{x + \theta}{2} \\ &= \frac{1}{\sqrt{a^2 + b^2}} \log \left| \tan \left(\frac{x}{2} + \frac{1}{2} \tan^{-1} \frac{b}{a} \right) \right|. \end{aligned}$$

Note. Since, as above, $\sin x + \cos x = \sqrt{2} \sin \left(x + \frac{\pi}{4} \right)$,

$$\begin{aligned}\therefore \int \frac{dx}{\sin x + \cos x} &= \frac{1}{\sqrt{2}} \int \operatorname{cosec} \left(x + \frac{\pi}{4} \right) dx \\ &= \frac{1}{\sqrt{2}} \log \tan \left(\frac{x}{2} + \frac{\pi}{8} \right) \Big|.\end{aligned}$$

Ex. 2. Integrate $\int \frac{dx}{a^2 \sin^2 x + b^2 \cos^2 x}$

Multiply the numerator and denominator by $\sec^2 x$ and put $\tan x = z$.

$$\begin{aligned}\therefore I &= \int \frac{dz}{a^2 z^2 + b^2} = \frac{1}{a^2} \int \frac{dz}{z^2 + k^2}, \text{ where } k = \frac{b}{a} \\ &= \frac{1}{a^2} \cdot \frac{1}{k} \tan^{-1} \frac{z}{k} = \frac{1}{ab} \tan^{-1} \left(\frac{a}{b} \tan x \right).\end{aligned}$$

Ex. 3. Integrate $\int \frac{dx}{5 - 13 \sin x}$

$$I = \int \frac{dx}{5 (\sin^2 \frac{1}{2}x + \cos^2 \frac{1}{2}x) - 13.2 \sin \frac{1}{2}x \cos \frac{1}{2}x}$$

Multiplying the numerator and denominator by $\sec^2 \frac{1}{2}x$, this

$$\begin{aligned}&= \int \frac{\sec^2 \frac{1}{2}x dx}{5 (\tan^2 \frac{1}{2}x + 1) - 26 \tan \frac{1}{2}x} \\ &= \int \frac{2dz}{5z^2 - 26z + 5}, \quad [\text{putting } \tan \frac{1}{2}x = z] \\ &= \frac{2}{5} \int \frac{dz}{(z - \frac{13}{5})^2 - (\frac{12}{5})^2} \\ &= \frac{2}{5} \int \frac{du}{u^2 - a^2}, \quad \text{where } u = z - \frac{13}{5} \text{ and } a = \frac{12}{5} \\ &= \frac{2}{5} \cdot \frac{1}{2a} \log \frac{u-a}{u+a} = \frac{1}{12} \log \frac{z-5}{z-\frac{1}{5}} \\ &= \frac{1}{12} \log \left| \frac{5 \tan \frac{1}{2}x - 25}{5 \tan \frac{1}{2}x - 1} \right|\end{aligned}$$

on restoring the value of z .

Ex. 4. Integrate $\int \frac{dx}{13 + 3 \cos x + 4 \sin x}$ [C. P. 1933]

$$I = \int \frac{dx}{13 (\sin^2 \frac{1}{2}x + \cos^2 \frac{1}{2}x) + 3 (\cos^2 \frac{1}{2}x - \sin^2 \frac{1}{2}x) + 4.2 \sin \frac{1}{2}x \cos \frac{1}{2}x}$$

Multiplying the numerator and denominator by $\sec^2 \frac{1}{2}x$, this

$$\begin{aligned} &= \int \frac{\sec^2 \frac{1}{2}x \, dx}{10 \tan^2 \frac{1}{2}x + 8 \tan \frac{1}{2}x + 16} \\ &= \int \frac{2 \, dz}{10z^2 + 8z + 16}, \quad [\text{putting } z = \tan \frac{1}{2}x] \\ &= \frac{1}{5} \int \frac{dz}{(z + \frac{2}{5})^2 + (\frac{6}{5})^2} = \frac{1}{5} \int \frac{du}{u^2 + a^2}, \\ &\qquad\qquad\qquad \text{where } u = z + \frac{2}{5}, \quad a = \frac{6}{5} \\ &= \frac{1}{5} \cdot \frac{1}{a} \tan^{-1} \frac{u}{a} = \frac{1}{6} \tan^{-1} \frac{5z + 2}{6} \\ &= \frac{1}{6} \tan^{-1} \frac{5 \tan \frac{1}{2}x + 2}{6}. \end{aligned}$$

Ex. 5. Integrate $\int \frac{2 \sin x + 3 \cos x}{3 \sin x + 4 \cos x} \, dx$.

Let $2 \sin x + 3 \cos x$

$$\begin{aligned} &= l (\text{denominator}) + m (\text{diff. of denominator}) \\ &= l (3 \sin x + 4 \cos x) + m (3 \cos x - 4 \sin x) \\ &= (3l - 4m) \sin x + (4l + 3m) \cos x. \end{aligned}$$

Now comparing coefficients of $\sin x$ and $\cos x$ on both sides, we get $3l - 4m = 2$ and $4l + 3m = 3$ whence $l = \frac{1}{5}$, $m = \frac{1}{5}$.

$$\therefore 2 \sin x + 3 \cos x = \frac{1}{5} (3 \sin x + 4 \cos x) + \frac{1}{5} (3 \cos x - 4 \sin x).$$

$$\begin{aligned} \therefore I &= \frac{18}{25} \int dx + \frac{1}{25} \int \frac{3 \cos x - 4 \sin x}{3 \sin x + 4 \cos x} \, dx \\ &= \frac{18}{25}x + \frac{1}{25} \log (3 \sin x - 4 \cos x). \end{aligned}$$

Note. Generally $\int \frac{a \sin x + b \cos x}{c \sin x + d \cos x} \, dx$ can be treated in the same way.

Ex. 6. Integrate $\int \frac{1}{\sin(x-a) \sin(x-b)} \, dx$.

$$\begin{aligned} \frac{1}{\sin(x-a) \sin(x-b)} &= \frac{1}{\sin(a-b)} \cdot \frac{\sin \{(x-b) - (x-a)\}}{\sin(x-a) \sin(x-b)} \\ &= \frac{1}{\sin(a-b)} \left[\frac{\cos(x-a)}{\sin(x-a)} - \frac{\cos(x-b)}{\sin(x-b)} \right]. \end{aligned}$$

$$\begin{aligned} \therefore I &= \frac{1}{\sin(a-b)} \left[\int \frac{\cos(x-a)}{\sin(x-a)} dx - \int \frac{\cos(x-b)}{\sin(x-b)} dx \right] \\ &= \frac{1}{\sin(a-b)} [\log \sin(x-a) - \log \sin(x-b)] \\ &= \frac{1}{\sin(a-b)} \log \frac{\sin(x-a)}{\sin(x-b)}. \end{aligned}$$

Ex. 7. Integrate $\int \frac{\tan x}{\sqrt{a+b \tan^2 x}} dx$, $b > a$.

$$\begin{aligned} I &= \int \frac{\sin x dx}{\sqrt{a \cos^2 x + b \sin^2 x}} = \int \frac{\sin x dx}{\sqrt{b - (b-a) \cos^2 x}} \\ &= \frac{1}{\sqrt{b-a}} \int \frac{\sin x dx}{\sqrt{\frac{b}{b-a} - \cos^2 x}} = \frac{1}{\sqrt{b-a}} \int \frac{dz}{\sqrt{k^2 - z^2}}, \\ & \qquad \qquad \qquad \left[\text{putting } z = \cos x \text{ and } k^2 = \frac{b}{b-a} \right] \\ &= \frac{1}{\sqrt{b-a}} \cos^{-1} \frac{z}{k} = \frac{1}{\sqrt{b-a}} \cos^{-1} \left[\sqrt{\frac{b-a}{b}} \cos x \right]. \\ & \qquad \qquad \qquad \text{[See Art. 23(E), Note]} \end{aligned}$$

Ex. 8. Integrate $\int \frac{dx}{3+4 \cosh x}$

$$\begin{aligned} I &= \int \frac{dx}{3(\cosh^2 \frac{1}{2}x - \sinh^2 \frac{1}{2}x) + 4(\cosh^2 \frac{1}{2}x + \sinh^2 \frac{1}{2}x)} \\ &= \int \frac{dx}{7 \cosh^2 \frac{1}{2}x + \sinh^2 \frac{1}{2}x} \\ &= \int \frac{\operatorname{sech}^2 \frac{1}{2}x}{7 + \tanh^2 \frac{1}{2}x} dx. \end{aligned}$$

(on multiplying the numerator and denominator by $\operatorname{sech}^2 \frac{1}{2}x$.)

Put $\tanh \frac{1}{2}x = z$; then $\frac{1}{2} \operatorname{sech}^2 \frac{1}{2}x dx = dz$.

$$\therefore I = 2 \int \frac{dz}{7+z^2} = \frac{2}{\sqrt{7}} \tan^{-1} \frac{z}{\sqrt{7}} = \frac{2}{\sqrt{7}} \tan^{-1} \left(\frac{1}{\sqrt{7}} \tanh \frac{1}{2}x \right).$$

EXAMPLES IV

Integrate with respect to x the following functions :—

1. (i) $\operatorname{cosec} 2x$. [C. P. 1929]

(ii) $\cos^3 x$.

(iii) $\sin^4 x$.

(iv) $\sin^5 x$.

(v) $\sin^2 x \cos^2 x$.

(vi) $\sin^3 x \cos^3 x$.

(vii) $\sin^4 x \cos^4 x$.

(viii) $\sin^2 x \cos^3 x$.

(ix) $\cos^2 x \sin^3 x$.

(x) $\sin 2x \cos^3 x$.

(xi) $\sin 3x \cos^3 x$.

(xii) $\sec^2 x \operatorname{cosec}^2 x$.

(xiii) $\sin^5 x \sec^6 x$.

2. (i) $\cot^3 x$. (ii) $\tan^4 x$. (iii) $\sec^6 x$.

(iv) $\operatorname{cosec}^4 x$. (v) $\operatorname{cosec}^5 x$. (vi) $\tan^2 x \sec^4 x$.

Evaluate the following integrals :—

3. (i) $\int \frac{\cos 2x}{\sin x} dx$.

(ii) $\int \frac{\cos 2x}{\cos x} dx$.

(iii) $\int \frac{\sin x}{\sin 2x} dx$.

(iv) $\int \frac{\cos x}{\cos 2x} dx$.

(v) $\int \left(\frac{\tan x}{\cos x} \right)^4 dx$.

(vi) $\int \frac{x \cos x}{\sin^2 x} dx$.

4. (i) $\int \sqrt{\sin x} \cos^3 x dx$.

(ii) $\int \frac{dx}{\sqrt{\sin^5 x \cos^7 x}}$.

5. (i) $\int \frac{dx}{(\sin x + \cos x)^2}$.

(ii) $\int \frac{dx}{1 + \sin 2x}$.

$$6. \int \frac{dx}{3 \sin x - 4 \cos x}$$

$$7. \int \frac{dx}{(3 \sin x + 4 \cos x)^2}$$

$$8. (i) \int \frac{\sin x}{\cos 2x} dx.$$

$$(ii) \int \frac{\sin x}{\sin 3x} dx.$$

$$9. (i) \int \frac{dx}{\cos^2 x - \sin^2 x}$$

$$(ii) \int \frac{dx}{1 - \sin^4 x}$$

$$10. \int \frac{\cot^2 x + 1}{\cot^2 x - 1} dx.$$

$$11. \int \frac{dx}{4 \cos^3 x - 3 \cos x}$$

$$12. (i) \int \frac{\sin^3 x}{\cos^{\frac{2}{3}} x} dx.$$

$$(ii) \int \frac{\sin^5 x}{\cos^2 x} dx.$$

$$13. (i) \int \frac{dx}{\sin x \cos^2 x}$$

$$(ii) \int \frac{dx}{\sin x \cos^3 x}$$

$$(iii) \int \frac{\sin 2x dx}{\sin 5x \sin 3x}$$

$$(iv) \int \frac{dx}{\cos 3x - \cos x}$$

[Put $\sin^2 x + \cos^2 x$ in the numerator of (i) and (ii).]

$$14. (i) \int \frac{dx}{\sin^4 x \cos^2 x}$$

$$(ii) \int \frac{dx}{\sin^4 x \cos^4 x}$$

[Put $\tan x = z$ in (i) and (ii).]

$$15. (i) \int \frac{\sqrt{\tan x}}{\sin x \cos x} dx.$$

$$(ii) \int \frac{\cos x - \sin x}{\sqrt{\sin 2x}} dx.$$

$$16. (i) \int \frac{dx}{4 - 5 \sin^2 x}$$

$$(ii) \int \frac{dx}{1 + \cos^2 x}$$

$$17. \quad (i) \int \frac{\sin 2x}{\sin^4 x + \cos^4 x} dx. \quad (ii) \int \frac{dx}{\sin^4 x + \cos^4 x}.$$

[(ii) Write $\sin^4 x + \cos^4 x = \cos^2 2x + \frac{1}{2} \sin^2 2x$.]

$$18. \quad (i) \int \frac{\sin x}{\sqrt{1 + \sin x}} dx. \quad (ii) \int \frac{\sin 2x dx}{(\sin x + \cos x)^2}.$$

$$19. \quad \int \frac{\sin x}{(1 + \cos x)^2} dx.$$

$$20. \quad (i) \int \frac{dx}{1 + \tan x}. \quad (ii) \int \frac{dx}{1 + \cos a \cos x}.$$

$$21. \quad (i) \int \frac{\cos x}{\sin x + \cos x} dx. \quad (ii) \int \frac{\cos x dx}{2 \sin x + 3 \cos x}.$$

[(i) Numerator = $\frac{1}{2}\{(\sin x + \cos x) + (\cos x - \sin x)\}$.]

$$(iii) \int \sqrt{\frac{\operatorname{cosec} x - \cot x}{\operatorname{cosec} x + \cot x}} \cdot \frac{\sec x}{\sqrt{1 + 2 \sec x}} dx.$$

$$22. \quad \int \frac{\sec x}{a + b \tan x} dx.$$

$$23. \quad \int \frac{dx}{a + b \tan x}$$

$$24. \quad \int \frac{dx}{a + b \sin x} \quad [C. P. 1933]$$

$$25. \quad (i) \int \frac{dx}{5 + 4 \sin x}. \quad (ii) \int \frac{dx}{4 + 5 \sin x}$$

$$(iii) \int \frac{dx}{4 + 3 \sinh x} \quad (iv) \int \frac{dx}{4 + 3 \cosh x}$$

$$26. \quad (i) \int \frac{dx}{5 + 4 \cos x}. \quad (ii) \int \frac{dx}{3 + 5 \cos x}$$

$$27. \quad (i) \int \frac{dx}{\cos a + \cos x}. \quad (ii) \int \frac{\cos x dx}{5 - 3 \cos x}$$

$$28. \int \frac{dx}{a^2 - b^2 \cos^2 x}$$

$$29. \int \frac{\sin x \, dx}{\sqrt{a^2 \cos^2 x + b^2 \sin^2 x}}$$

$$30. \int \frac{\sin 2x \, dx}{(a + b \cos x)^2}$$

$$31. \int \frac{11 \cos x - 16 \sin x}{2 \cos x + 5 \sin x} \, dx.$$

$$32. (i) \int \frac{dx}{1 - \cos x + \sin x}$$

$$(ii) \int \frac{dx}{3 + 2 \sin x + \cos x}$$

$$33. \int \frac{6 + 3 \sin x + 14 \cos x}{3 + 4 \sin x + 5 \cos x} \, dx.$$

$$34. \int \sqrt{1 + \sec x} \, dx \quad [\text{Put } \sqrt{2} \sin \frac{1}{2}x = z.]$$

$$35. (i) \int \frac{1}{\sec x + \operatorname{cosec} x} \, dx. \quad (ii) \int \frac{dx}{\sin x + \tan x}$$

$$36. (i) \int \left(\sqrt{\tan x} + \sqrt{\cot x} \right) \, dx. \quad (ii) \int \sqrt{\cot x} \, dx.$$

[(i) Put $\sin x - \cos x = z$ and note $2 \sin x \cos x = 1 - (\sin x - \cos x)^2$.]

$$37. \int \sqrt{\left\{ \frac{\sin(x-a)}{\sin(x+a)} \right\}} \, dx.$$

$$38. \int \frac{x^2 \, dx}{(x \sin x + \cos x)^2}$$

ANSWERS

1. (i) $\frac{1}{2} \log \tan x$. (ii) $\sin x - \frac{1}{3} \sin^3 x$. (iii) $\frac{2}{3}x - \frac{1}{3} \sin 2x + \frac{1}{3} \sin 4x$.
 (iv) $\frac{2}{3} \cos^3 x - \cos x - \frac{1}{3} \cos^5 x$. (v) $\frac{1}{3}x - \frac{1}{3} \sin 4x$.
 (vi) $\frac{1}{4} \sin^4 x - \frac{1}{8} \sin^6 x$. (vii) $\frac{1}{12} [3x - \sin 4x + \frac{1}{3} \sin 8x]$.
 (viii) $\frac{1}{3} \sin^3 x - \frac{1}{5} \sin^5 x$. (ix) $\frac{1}{6} \cos^6 x - \frac{1}{3} \cos^4 x$. (x) $-\frac{2}{5} \cos^5 x$.
 (xi) $\frac{2}{3} \sin^2 x - \frac{7}{4} \sin^4 x + \frac{2}{3} \sin^6 x$. (xii) $\tan x - \cot x$.
 (xiii) $\sec x - \frac{2}{3} \sec^3 x + \frac{1}{5} \sec^5 x$.
2. (i) $-\frac{1}{2} \cot^2 x - \log \sin x$. (ii) $\frac{1}{3} \tan^3 x - \tan x + x$.
 (iii) $\tan x (1 + \frac{2}{3} \tan^2 x + \frac{1}{6} \tan^4 x)$. (iv) $-\cot x - \frac{1}{3} \cot^3 x$.
 (v) $-\frac{1}{2} \cot x \operatorname{cosec}^3 x - \frac{2}{3} \cot x \operatorname{cosec} x + \frac{2}{3} \log \tan \frac{1}{2}x$.
 (vi) $\tan^3 x (\frac{1}{3} + \frac{1}{5} \tan^2 x)$.
3. (i) $\log \tan \frac{1}{2}x + 2 \cos x$.
 (ii) $2 \sin x - \log (\sec x + \tan x)$. (iii) $\frac{1}{2} \log (\sec x + \tan x)$.
 (iv) $\frac{1}{2\sqrt{2}} \log \frac{1 + \sqrt{2} \sin x}{1 - \sqrt{2} \sin x}$. (v) $\frac{1}{5} \tan^5 x + \frac{1}{7} \tan^7 x$.
- (vi) $\log \tan \frac{1}{2}x - x \operatorname{cosec} x$. 4. (i) $\frac{2}{3} \sqrt{\sin x} (7 \sin x - 3 \sin^3 x)$.
 (ii) $2 \cot^2 x (\frac{1}{3} \tan^4 x + 2 \tan^2 x - \frac{1}{3})$. 5. (i) & (ii) $-\frac{1}{1 + \tan x}$.
6. $\frac{1}{5} \log \tan (\frac{1}{2}x - \frac{1}{2} \tan^{-1} \frac{4}{3})$. 7. $-\frac{1}{3(3 \tan x + 4)}$.
8. (i) $\frac{1}{2\sqrt{2}} \log \frac{1 + \sqrt{2} \cos x}{1 - \sqrt{2} \cos x}$. (ii) $\frac{1}{2\sqrt{3}} \log \frac{\sqrt{3} + \tan x}{\sqrt{3} - \tan x}$.
9. (i) $\frac{1}{2} \log \tan (\frac{1}{4}\pi + x)$ (ii) $\frac{1}{2} \tan x + \frac{1}{2\sqrt{2}} \tan^{-1}(\sqrt{2} \tan x)$.
10. $\frac{1}{2} \log \tan (\frac{1}{4}\pi + x)$. 11. $\frac{1}{3} \log \tan (\frac{1}{4}\pi + \frac{2}{3}x)$.
12. (i) $-\frac{2}{3} \cos^3 x + \frac{1}{15} \cos^5 x$. (ii) $\sec x + 2 \cos x - \frac{1}{3} \cos^3 x$.
13. (i) $\sec x + \log \tan \frac{1}{2}x$. (ii) $\frac{1}{2} \tan^2 x + \log \tan x$.
 (iii) $\frac{1}{3} \log \sin 3x - \frac{1}{5} \log \sin 5x$. (iv) $\frac{1}{4} [\operatorname{cosec} x - \log (\sec x + \tan x)]$.
14. (i) $\tan x - 2 \cot x - \frac{1}{3} \cot^3 x$. (ii) $\frac{1}{3} (\tan^3 x - \cot^3 x) + 3(\tan x - \cot x)$.
15. (i) $2 \sqrt{\tan x}$. (ii) $\log (\cos x + \sin x + \sqrt{\sin 2x})$.

16. (i) $\frac{1}{4} \log \frac{2 + \tan x}{2 - \tan x}$. (ii) $\frac{1}{\sqrt{2}} \tan^{-1} \left(\frac{\tan x}{\sqrt{2}} \right)$.
17. (i) $\tan^{-1}(\tan^2 x)$. (ii) $\frac{1}{\sqrt{2}} \tan^{-1} \left(\frac{1}{\sqrt{2}} \tan 2x \right)$.
18. (i) $2\sqrt{1 - \sin x} - \sqrt{2} \log \tan \left(\frac{1}{2}x + \frac{1}{8}\pi \right)$.
 (ii) $x + \frac{1}{1 + \tan x}$ 19. $2 \tan \frac{1}{2}x - x$.
20. (i) $\frac{1}{2} \{x + \log(\sin x + \cos x)\}$. (ii) $2 \operatorname{cosec} a \tan^{-1}(\tan \frac{1}{2}a \tan \frac{1}{2}x)$.
21. (i) $\frac{1}{2} \{x + \log(\sin x + \cos x)\}$. (ii) $\frac{1}{1^2}x + \frac{1}{1^2} \log(2 \sin x + 3 \cos x)$.
 (iii) $\sin^{-1}(\frac{1}{2} \sec^2 \frac{1}{2}x)$.
22. $\frac{1}{\sqrt{a^2 + b^2}} \log \tan \left(\frac{x}{2} + \frac{1}{2} \tan^{-1} \frac{a}{b} \right)$.
23. $\frac{a}{a^2 + b^2}x + \frac{b}{a^2 + b^2} \log(a \cos x + b \sin x)$.
24. $\frac{2}{\sqrt{a^2 - b^2}} \tan^{-1} \left\{ \frac{a \tan \frac{1}{2}x + b}{\sqrt{a^2 - b^2}} \right\}$, if $a > b$;
 $\frac{1}{\sqrt{b^2 - a^2}} \log \left\{ \frac{a \tan \frac{1}{2}x + b - \sqrt{b^2 - a^2}}{a \tan \frac{1}{2}x + b + \sqrt{b^2 - a^2}} \right\}$, if $a < b$.
25. (i) $\frac{2}{3} \tan^{-1} \frac{1}{3} (5 \tan \frac{1}{2}x + 4)$. (ii) $\frac{1}{3} \log \frac{2 \tan \frac{1}{2}x + 1}{2 \tan \frac{1}{2}x + 4}$.
 (iii) $\frac{1}{5} \log \frac{1 + 2 \tanh \frac{1}{2}x}{4 - 2 \tanh \frac{1}{2}x}$. (iv) $\frac{1}{\sqrt{7}} \log \frac{\sqrt{7} + \tanh \frac{1}{2}x}{\sqrt{7} - \tanh \frac{1}{2}x}$.
26. (i) $\frac{2}{3} \tan^{-1} \left(\frac{1}{3} \tan \frac{1}{2}x \right)$. (ii) $\frac{1}{4} \log \left(\frac{2 + \tan \frac{1}{2}x}{2 - \tan \frac{1}{2}x} \right)$.
27. (i) $\frac{1}{\sin a} \log \frac{\cos \frac{1}{2}(x-a)}{\cos \frac{1}{2}(x+a)}$. (ii) $-\frac{1}{3}x + \frac{4}{3} \tan^{-1}(2 \tan \frac{1}{2}x)$.
28. $\frac{1}{a\sqrt{a^2 - b^2}} \tan^{-1} \left(\frac{a}{\sqrt{a^2 - b^2}} \tan x \right)$, if $a > b$;
 $\frac{1}{2a\sqrt{b^2 - a^2}} \log \frac{a \tan x - \sqrt{b^2 - a^2}}{a \tan x + \sqrt{b^2 - a^2}}$, if $a < b$.

$$29. -\frac{1}{\sqrt{a^2-b^2}} \log (\sqrt{a^2-b^2} \cos x + \sqrt{a^2 \cos^2 x + b^2 \sin^2 x}),$$

$$\text{if } a > b; -\frac{1}{\sqrt{b^2-a^2}} \sin^{-1} \left(\frac{\sqrt{b^2-a^2}}{b} \cos x \right), \text{ if } a < b.$$

$$30. -2b^{-2} \log (a+b \cos x) - 2ab^{-2} (a+b \cos x)^{-1}.$$

$$31. 3 \log (2 \cos x + 5 \sin x) - 2x.$$

$$32. (i) -\log (1 + \cot \frac{1}{2}x).$$

$$(ii) \tan^{-1}(1 + \tan \frac{1}{2}x).$$

$$33. 2x + \log (3 + 4 \sin x + 5 \cos x).$$

$$34. 2 \sin^{-1}(\sqrt{2} \sin \frac{1}{2}x).$$

$$35. (i) \frac{1}{2} [\sin x - \cos x - \frac{1}{\sqrt{2}} \log \tan (\frac{1}{2}x + \frac{1}{4}\pi)].$$

$$(ii) \frac{1}{2} \log \tan \frac{1}{2}x - \frac{1}{4} \tan^2 \frac{1}{2}x.$$

$$36. \sqrt{2} \sin^{-1} (\sin x - \cos x).$$

$$37. \cos a \cos^{-1}(\cos x \sec a) - \sin a \log (\sin x + \sqrt{\sin^2 x - \sin^2 a}).$$

$$38. \frac{\sin x - x \cos x}{x \sin x + \cos x}$$

CHAPTER V
RATIONAL FRACTIONS

[*Method of breaking up into partial fractions*]

5.1. Integration of Rational Fractions.

When we have to integrate a rational fraction, say $\frac{f(x)^*}{\phi(x)}$, if $f(x)$ be not of a lower degree than $\phi(x)$, we shall first

express $\frac{f(x)}{\phi(x)}$ by ordinary division in the form

$$C_p x^p + C_{p-1} x^{p-1} + \dots + C_0 + \frac{\psi(x)}{\phi(x)},$$

where $C_p x^p + \dots + C_0$ is the quotient, and $\psi(x)$ is the remainder and hence of lower degree than $\phi(x)$.

$$\text{Then } \int \frac{f(x)}{\phi(x)} dx = C_p \frac{x^{p+1}}{p+1} + \dots + C_0 x + \int \frac{\psi(x)}{\phi(x)} dx.$$

So we shall now consider how to integrate that rational fraction $\frac{\psi(x)}{\phi(x)}$ in which *the numerator is of a lower degree than the denominator*. The best way of effecting the integration is first to decompose the fraction into a number of partial fractions and then to integrate each term separately.

*When $f(x)$ and $\phi(x)$ are algebraic expressions containing terms involving positive integral powers of x only, of the form

$$a_0 + a_1 x + a_2 x^2 + \dots + a_n x^n.$$

We shall not enter here into a detailed discussion of the theory of partial fractions for which the student is referred to treatises on Higher Algebra, but we shall briefly indicate the different methods adopted in breaking up a fraction into partial fractions according to the nature of the factors of the denominator of the fraction.

We know from the Theory of Equations that $\phi(x)$ can always be broken up into real factors which may be linear or quadratic and some of which may be repeated.

Thus the general form of $\phi(x)$ is

$$A(x - \alpha)(x - \beta) \cdots (x - \gamma)^p (x - \delta)^q \cdots \{(x - l)^2 + m^2\} \cdots \\ \cdots \{(x - l')^2 + m'^2\}^r.$$

Case I. *When the denominator contains factors, real, linear, but none repeated.*

To each non-repeated linear factor of the denominator, such as $x - a$, there corresponds a partial fraction of the form $\frac{A}{x - a}$, where A is a constant. The given fraction can be expressed as a sum of fractions of this type and the unknown constants A 's can be determined easily as shown by the following examples.

Ex. 1. Integrate $\int \frac{x^2 + x - 1}{x^3 + x^2 - 6x} dx$. [P. P. 1931]

$$x^3 + x^2 - 6x = x(x^2 + x - 6) = x(x + 3)(x - 2).$$

Let $\frac{x^2 + x - 1}{x(x + 3)(x - 2)} = \frac{A}{x} + \frac{B}{x + 3} + \frac{C}{x - 2}$.

Multiplying both sides by $x(x+3)(x-2)$, we get

$$x^2 + x - 1 = A(x+3)(x-2) + Bx(x-2) + Cx(x+3).$$

Putting $x=0, -3, 2$ successively on both sides, we get

$$A = \frac{1}{6}, B = \frac{1}{3}, C = \frac{1}{2}.$$

\therefore the given integral is

$$\begin{aligned} & \frac{1}{6} \int \frac{dx}{x} + \frac{1}{3} \int \frac{dx}{x+3} + \frac{1}{2} \int \frac{dx}{x-2} \\ & = \frac{1}{6} \log x + \frac{1}{3} \log(x+3) + \frac{1}{2} \log(x-2). \end{aligned}$$

Ex. 2. Integrate $\int \frac{x^3}{(x-a)(x-b)(x-c)} dx.$

Here numerator is of the same degree as denominator and if the numerator be divided by the denominator, the fraction would be of the form

$$1 + \frac{P}{Q}, \text{ where } Q \equiv (x-a)(x-b)(x-c) \text{ and } P \text{ of lower degree than } Q.$$

Hence, we can write

$$\frac{x^3}{(x-a)(x-b)(x-c)} = 1 + \frac{A}{x-a} + \frac{B}{x-b} + \frac{C}{x-c}. \quad (1)$$

$$\begin{aligned} \therefore x^3 &= (x-a)(x-b)(x-c) + A(x-b)(x-c) \\ &+ B(x-c)(x-a) + C(x-a)(x-b). \end{aligned} \quad (2)$$

Putting $x=a, b, c$ successively on both sides of the above identity (2), we get

$$A = \frac{a^3}{(a-b)(a-c)}, \quad B = \frac{b^3}{(b-c)(b-a)}, \quad C = \frac{c^3}{(c-a)(c-b)}.$$

\therefore from (1), it follows that the given integral

$$\begin{aligned} &= \int dx + \frac{a^3}{(a-b)(a-c)} \int \frac{dx}{x-a} + \frac{b^3}{(b-c)(b-a)} \int \frac{dx}{x-b} \\ &+ \frac{c^3}{(c-a)(c-b)} \int \frac{dx}{x-c} \\ &= x + \frac{a^3}{(a-b)(a-c)} \log(x-a) + \frac{b^3}{(b-c)(b-a)} \log(x-b) \\ &+ \frac{c^3}{(c-a)(c-b)} \log(x-c). \end{aligned}$$

Case II. *When the denominator contains factors, real, linear, but some repeated.*

To each p -fold linear factor, such as $(x - a)^p$ there will correspond the sum of p partial fractions of the form

$$\frac{A_p}{(x - a)^p} + \frac{A_{p-1}}{(x - a)^{p-1}} + \dots + \frac{A_1}{(x - a)},$$

where the constants A_p, A_{p-1}, \dots, A_1 can be evaluated easily.

Ex. 3. *Integrate* $\int \frac{x^2}{(x+1)^2(x+2)} dx$.

Let
$$\frac{x^2}{(x+1)^2(x+2)} = \frac{A}{(x+1)^2} + \frac{B}{x+1} + \frac{C}{x+2}.$$

Multiplying both sides by $(x+1)^2(x+2)$, we get

$$x^2 = A(x+2) + B(x+1)(x+2) + C(x+1)^2.$$

Putting $x = -1, -2$ successively, we get $A = 1, C = 4$.

Again, equating coefficients of x^2 on both sides,

$$B + C = 1; \quad \therefore B = -3, \text{ since } C = 4.$$

$$\begin{aligned} \therefore \text{ the given integral} &= \int \frac{dx}{(x+1)^2} - 3 \int \frac{dx}{x+1} + 4 \int \frac{dx}{x+2} \\ &= -\frac{1}{x+1} - 3 \log(x+1) + 4 \log(x+2). \end{aligned}$$

Note. The partial fractions in the above case can also be obtained in the following way. Denote the first power of the repeated factor i.e., $x+1$ by z , then the fraction $= \frac{1}{z^2} \cdot \frac{(z-1)^2}{z+1}$. Now, divide Num. by Denom. of the 2nd fraction after writing them in ascending powers of z , till highest power of the repeated factor, viz., z^2 , appears in the remainder. Thus the fraction $= \frac{1}{z^2} \left(1 - 3z + \frac{4z^2}{1+z} \right) = \frac{1}{z^2} - \frac{3}{z} + \frac{4}{1+z}$. Now replace z by $x+1$, and the reqd. fractions are obtained.

Case III. *When the denominator contains factors, real, quadratic, but none repeated.*

To each non-repeated quadratic factor, such as $x^2 + px + q$, (or, $x^2 + q$, $q \neq 0$), there corresponds a partial fraction of the form $\frac{Ax + B}{x^2 + px + q}$, the method of integration of which is explained in Art. 2'5.

Ex. 4. Integrate $\int \frac{x}{(x-1)(x^2+4)} dx$.

$$\text{Let } \frac{x}{(x-1)(x^2+4)} = \frac{A}{x-1} + \frac{Bx+C}{x^2+4}.$$

$$\therefore x = A(x^2+4) + (Bx+C)(x-1).$$

Putting $x=1$, on both sides, we get $A = \frac{1}{5}$.

Equating coefficients of x^2 and x on both sides, we get

$$A + B = 0 \text{ and } C - B = 1; \text{ hence } B = -\frac{1}{5}, C = \frac{4}{5}.$$

\therefore the given integral becomes

$$\begin{aligned} \frac{1}{5} \int \frac{dx}{x-1} - \frac{1}{5} \int \frac{x-4}{x^2+4} dx &= \frac{1}{5} \int \frac{dx}{x-1} - \frac{1}{10} \int \frac{2x dx}{x^2+4} + \frac{4}{5} \int \frac{dx}{x^2+4} \\ &= \frac{1}{5} \log(x-1) - \frac{1}{10} \log(x^2+4) + \frac{2}{5} \tan^{-1} \frac{x}{2}. \end{aligned}$$

Ex. 5. Integrate $\int \frac{dx}{(x^2+a^2)(x^2+b^2)}$. [C. P. 1928, '31, '37]

$$\frac{1}{(x^2+a^2)(x^2+b^2)} = \frac{1}{a^2-b^2} \left[\frac{1}{x^2+b^2} - \frac{1}{x^2+a^2} \right].$$

$$\begin{aligned} \therefore \text{ the given integral} &= \frac{1}{a^2-b^2} \left[\int \frac{dx}{x^2+b^2} - \int \frac{dx}{x^2+a^2} \right] \\ &= \frac{1}{a^2-b^2} \left[\frac{1}{b} \tan^{-1} \frac{x}{b} - \frac{1}{a} \tan^{-1} \frac{x}{a} \right]. \end{aligned}$$

Ex. 6. Integrate $\int \frac{dx}{x^3+1}$.

Since, $x^3+1=(x+1)(x^2-x+1)$,

let us assume $\frac{1}{x^3+1}=\frac{A}{x+1}+\frac{Bx+C}{x^2-x+1}$.

$\therefore 1=A(x^2-x+1)+(Bx+C)(x+1)$.

Putting $x=-1$, we get $A=\frac{1}{3}$.

Equating the coefficients of x^2 , and the constant terms, we have

$$A+B=0 \text{ and } A+C=1. \quad \therefore B=-\frac{1}{3}, C=\frac{2}{3}.$$

\therefore the given integral becomes

$$\begin{aligned} & \frac{1}{3} \int \frac{dx}{x+1} - \frac{1}{3} \int \frac{x-2}{x^2-x+1} dx \\ &= \frac{1}{3} \int \frac{dx}{x+1} - \frac{1}{6} \int \frac{(2x-1)-3}{x^2-x+1} dx \\ &= \frac{1}{3} \int \frac{dx}{x+1} - \frac{1}{6} \int \frac{2x-1}{x^2-x+1} dx + \frac{1}{2} \int \frac{dx}{x^2-x+1} \\ &= \frac{1}{3} \log(x+1) - \frac{1}{6} \log(x^2-x+1) + \frac{1}{2} \int \frac{dx}{(x-\frac{1}{2})^2 + (\frac{\sqrt{3}}{2})^2} \\ &= \frac{1}{3} \log(x+1) - \frac{1}{6} \log(x^2-x+1) + \frac{1}{2} \cdot \frac{2}{\sqrt{3}} \tan^{-1} \left(\frac{2x-1}{\sqrt{3}} \right) \\ &= \frac{1}{3} \log(x+1) - \frac{1}{6} \log(x^2-x+1) + \frac{1}{\sqrt{3}} \tan^{-1} \left(\frac{2x-1}{\sqrt{3}} \right). \end{aligned}$$

Case IV. When the denominator contains factors real, quadratic, but some repeated.

In this case we shall require the use of Reduction Formula to perform the integration, for the general discussion of which see Chap. VIII.

Ex. 7. Integrate $\int \frac{dx}{(1+x^2)^2}$.

Although this case comes under Case (IV), it can be treated more simply as follows : Put $x = \tan \theta$.

$$\begin{aligned} \therefore I &= \int \frac{\sec^2 \theta \, d\theta}{\sec^4 \theta} = \int \cos^2 \theta \, d\theta \\ &= \int \frac{1}{2} (1 + \cos 2\theta) \, d\theta = \frac{1}{2} \left(\theta + \frac{1}{2} \sin 2\theta \right) \\ &= \frac{1}{2} \left\{ \theta + \frac{1}{2} \cdot \frac{2 \tan \theta}{1 + \tan^2 \theta} \right\} \\ &= \frac{1}{2} \left\{ \tan^{-1} x + \frac{x}{1+x^2} \right\}. \end{aligned}$$

5.2. Two Special Cases.

(A) In many cases if *the numerator and the denominator of a given fraction contain even powers of x only*, we can first write the fraction in a simpler form by putting z for x^2 , and then break it up into partial fractions involving z , *i.e.*, x^2 , and then integrate it. Thus,

Ex. 8. Integrate $\int \frac{x^2}{x^4+x^2-2} \, dx$.

Putting $x^2 = z$, we have

$$\frac{x^2}{x^4+x^2-2} = \frac{z}{z^2+z-2} = \frac{z}{(z+2)(z-1)} = \frac{A}{z+2} + \frac{B}{z-1} \text{ say.}$$

$$\therefore z = A(z-1) + B(z+2).$$

Putting $z = -2$ and 1 respectively, we get $A = \frac{2}{3}$, $B = \frac{1}{3}$.

$$\frac{x^2}{x^4+x^2-2} = \frac{2}{3} \cdot \frac{1}{x^2+2} + \frac{1}{3} \cdot \frac{1}{x^2-1}.$$

$$\begin{aligned} I &= \frac{2}{3} \int \frac{dx}{x^2+2} + \frac{1}{3} \int \frac{dx}{x^2-1} \\ &= \frac{2}{3} \cdot \frac{1}{\sqrt{2}} \tan^{-1} \frac{x}{\sqrt{2}} + \frac{1}{3} \cdot \frac{1}{2} \log \frac{x-1}{x+1}. \end{aligned}$$

(B) If in a fraction, the numerator contains only odd powers of x and the denominator only even powers, then it is found more convenient to change the variable first by putting $x^2 = z$ and then break it up into partial fractions as usual. Thus,

Ex. 9. Integrate $\int \frac{x^3 dx}{x^4 + 3x^2 + 2}$.

Put $x^2 = z$. $\therefore 2x dx = dz$, $\therefore x^3 dx = \frac{1}{2}z dz$.

$$I = \frac{1}{2} \int \frac{z dz}{z^2 + 3z + 2}$$

Now, $\frac{z}{z^2 + 3z + 2} = \frac{z}{(z+1)(z+2)} = \frac{A}{z+1} + \frac{B}{z+2}$ say.

We determine as usual $A = -1$, $B = 2$.

$$\begin{aligned} \therefore I &= \frac{1}{2} \left[2 \int \frac{dz}{z+2} - \int \frac{dz}{z+1} \right] = \frac{1}{2} \left[2 \log (z+2) - \log (z+1) \right] \\ &= \log (x^2 + 2) - \frac{1}{2} \log (x^2 + 1). \end{aligned}$$

5.3. Integral of the form

$$\int \frac{dx}{(x-a)^m(x-b)^n}$$

where m and n are positive integers and a and b are unequal, positive or negative.

Put $x - a = z(x - b)$.

Ex. 10. Integrate $\int \frac{dx}{(x-1)^2(x-2)^3}$.

Put $x - 1 = z(x - 2)$

$$\therefore x = \frac{1-2z}{1-z} \quad \therefore dx = -\frac{dz}{(1-z)^2}$$

Hence, the integral transforms into

$$\begin{aligned} \int \frac{(1-z)^3}{z^2} dz &= \int \frac{1-3z+3z^2-z^3}{z^2} dz \\ &= -\frac{1}{z} - 3 \log z + 3z - \frac{1}{2}z^2 \\ &= -\left(\frac{x-2}{x-1}\right) - 3 \log \left(\frac{x-1}{x-2}\right) + 3\left(\frac{x-1}{x-2}\right) - \frac{1}{2}\left(\frac{x-1}{x-2}\right)^2. \end{aligned}$$

EXAMPLES V

Integrate the following :

1. $\int \frac{(x-1) dx}{(x-2)(x-3)}$ [C. P. 1937]

2. $\int \frac{x dx}{(x-a)(x-b)}$ [C. P. 1923]

3. $\int \frac{(x-1) dx}{(x+2)(x-3)}$ [C. P. 1924]

4. (i) $\int \frac{x dx}{x^2 - 12x + 35}$ (ii) $\int \frac{3x dx}{x^2 - x - 2}$

5. $\int \frac{x^2 dx}{(x-1)(x-2)(x-3)}$

6. (i) $\int \frac{(2x+3) dx}{x^3 + x^2 - 2x}$ (ii) $\int \frac{(x^2+1) dx}{x(x^2-1)}$

7. (i) $\int \frac{x^3 dx}{x^2 + 7x + 12}$ (ii) $\int \frac{(x-1)(x-5)}{(x-2)(x-4)} dx$

8. (i) $\int \frac{1-3x^2}{3x-x^3} dx$ (ii) $\int \frac{x dx}{(3-x)(3+2x)}$

9. (i) $\int \frac{x^2 dx}{(x-a)(x-b)(x-c)}$ (ii) $\int \frac{dx}{(x-a)^2(x-b)}$

- (iii) $\int \frac{dx}{(x-2)^2(x-1)^3}$ (iv) $\int \frac{dx}{(x+1)^2(x+2)^3}$
10. (i) $\int \frac{x^2 dx}{(x+1)(x+2)^2}$ (ii) $\int \frac{(3-x)}{x^2+x^3} dx$
11. (i) $\int \frac{dx}{x^3-x^2-x+1}$ (ii) $\int \frac{dx}{x(x+1)^2}$
12. (i) $\int \frac{dx}{(x^2-1)^2}$ (ii) $\int \frac{(x+1) dx}{(x-1)^2(x+2)^2}$
13. (i) $\int \frac{dx}{(x-1)^3(x+1)}$ (ii) $\int \frac{(3x+2) dx}{x(x+1)^3}$
14. (i) $\int \frac{dx}{1-x^3}$ (ii) $\int \frac{2+x^2}{1-x^3} dx$
15. (i) $\int \frac{x}{x^4-1} dx$ (ii) $\int \frac{dx}{x(x^4-1)}$
16. (i) $\int \frac{x^2}{1-x^4} dx$ (ii) $\int \frac{dx}{x^4-1}$
17. (i) $\int \frac{x dx}{(x^2+a^2)(x^2+b^2)}$ (ii) $\int \frac{x^2 dx}{(x^2+a^2)(x^2+b^2)}$
18. (i) $\int \frac{x^3 dx}{(x^2+a^2)(x^2+b^2)}$ (ii) $\int \frac{x^4 dx}{(x^2+a^2)(x^2+b^2)}$
19. $\int \frac{dx}{(x^2+a^2)(x+b)}$
20. (i) $\int \frac{x dx}{(1+x)(1+x^2)}$ (ii) $\int \frac{x}{x^3-1} dx$
21. $\int \frac{(x^2-1)}{x^4+x^2+1} dx$
22. (i) $\int \frac{x^2 dx}{x^4-x^2-12}$ (ii) $\int \frac{x dx}{x^4-x^2-1}$

$$23. \int \frac{dx}{(x^2 + 4x + 5)^2}$$

$$24. \int \frac{x^2 dx}{(x^2 + 1)(2x^2 + 1)}$$

$$25. \int \frac{dx}{x(1 + x + x^2 + x^3)}$$

$$26. \int \frac{dx}{x^4 + x^2 + 1}$$

$$[x^4 + x^2 + 1 = (x^2 + x + 1)(x^2 - x + 1)]$$

$$27. (i) \int \frac{dx}{x^4 + 1} \quad (ii) \int \frac{x^2 + 1}{x^4 + 1} dx$$

$$[x^4 + 1 = (x^2 + x\sqrt{2} + 1)(x^2 - x\sqrt{2} + 1)]$$

$$28. (i) \int \frac{dx}{\cos x (5 + 3 \cos x)} \quad (ii) \int \frac{dx}{\sin 2x - \sin x}$$

$$29. (i) \int \frac{dx}{1 + 3e^x + 2e^{2x}} \quad (ii) \int \frac{e^x dx}{e^x - 3e^{-x} + 2}$$

$$30. \int \frac{dx}{\sin x (3 + 2 \cos x)} \quad [Put \cos x = z] \quad [P. P. 1932]$$

$$31. \text{ Show that } \int \frac{dx}{\phi(x)}, \text{ where } \phi(x) = \prod_{r=0}^n (x + r)$$

$$= \frac{1}{n!} \left[\log x + \sum_{r=1}^n (-1)^r \binom{n}{r} \log (x + r) \right]$$

$$32. \text{ Show that } \int \frac{x^{n-1}}{f(x)} dx$$

$$= \sum_{r=1}^n \frac{(a_r)^{n-1}}{f'(a_r)} \log (x - a_r)$$

$$\text{where } f(x) = \prod_{r=1}^n (x - a_r), [a_i \neq a_k \text{ if } i \neq k]$$

ANSWERS

1. $2 \log (x-3) - \log (x-2)$.
2. $\frac{1}{a-b} \{a \log (x-a) - b \log (x-b)\}$.
3. $\frac{1}{5} \{3 \log (x+2) + 2 \log (x-3)\}$.
4. (i) $\frac{1}{2} \{7 \log (x-7) - 5 \log (x-5)\}$. (ii) $\log \{(x-2)^2 (x+1)\}$.
5. $\frac{1}{2} \log (x-1) - 4 \log (x-2) + \frac{9}{2} \log (x-3)$.
6. (i) $\frac{5}{3} \log (x-1) - \frac{5}{2} \log x - \frac{1}{6} \log (x+2)$. (ii) $\log (x^2-1) - \log x$.
7. (i) $\frac{1}{2} x^2 - 7x - 27 \log (x+3) + 64 \log (x+4)$. (ii) $x - \frac{3}{2} \log \frac{x-4}{x-2}$.
8. (i) $\frac{1}{3} \log \{x (x^2-3)^4\}$. (ii) $-\frac{1}{3} \log (3-x) - \frac{1}{6} \log (3+2x)$.
9. (i) $\frac{a^2}{(a-b)(a-c)} \log (x-a) + \frac{b^2}{(b-c)(b-a)} \log (x-b)$
 $+ \frac{c^2}{(c-a)(c-b)} \log (x-c)$.
 (ii) $\frac{1}{(b-a)(x-a)} + \frac{1}{(b-a)^2} \log \frac{x-b}{x-a}$.
 (iii) $-\frac{x-1}{x-2} - 3 \log \frac{x-2}{x-1} + 3 \frac{x-2}{x-1} - \frac{1}{2} (x-2)^2$.
 (iv) $-\frac{x+2}{x+1} - 3 \log \frac{x+1}{x+2} + 3 \frac{x+1}{x+2} - \frac{1}{2} (x+2)^2$.
10. (i) $\frac{4}{x+2} + \log (x+1)$. (ii) $-\frac{3}{x} - 4 \log x + 4 \log (x+1)$.
11. (i) $-\frac{1}{2(x-1)} + \frac{1}{4} \log \frac{x+1}{x-1}$. (ii) $\frac{1}{x+1} + \log \frac{x}{x+1}$.
12. (i) $\frac{1}{4} \log \frac{x+1}{x-1} - \frac{1}{2} \frac{x}{x^2-1}$.
 (ii) $\frac{1}{9} \left(\frac{1}{x+2} - \frac{2}{x-1} - \frac{1}{3} \log \frac{x-1}{x+2} \right)$.
13. (i) $\frac{1}{4} \left\{ \frac{x-2}{(x-1)^2} + \frac{1}{2} \log \frac{x-1}{x+1} \right\}$. (ii) $2 \log \frac{x}{x+1} + \frac{4x+3}{2(x+1)^2}$.
14. (i) $\frac{1}{\sqrt{3}} \tan^{-1} \frac{2x+1}{\sqrt{3}} - \frac{1}{3} \log \frac{1-x}{\sqrt{1+x+x^2}}$.

$$(ii) \log(1-x) + \frac{2}{\sqrt{3}} \tan^{-1} \frac{2x+1}{\sqrt{3}}.$$

$$15. (i) \frac{1}{4} \{\log(x^2-1) - \log(x^2+1)\}. \quad (ii) \frac{1}{4} \log(x^2-1) - \log x.$$

$$16. (i) \frac{1}{4} \{\log(1+x) - \log(1-x)\} - \frac{1}{2} \tan^{-1} x.$$

$$(ii) \frac{1}{4} \log \frac{x-1}{x+1} - \frac{1}{2} \tan^{-1} x.$$

$$17. (i) \frac{1}{2(a^2-b^2)} \log \frac{x^2+b^2}{x^2+a^2}. \quad (ii) \frac{1}{a^2-b^2} \left\{ a \tan^{-1} \frac{x}{a} - b \tan^{-1} \frac{x}{b} \right\}.$$

$$18. (i) \frac{1}{2(a^2-b^2)} \{a^2 \log(x^2+a^2) - b^2 \log(x^2+b^2)\}.$$

$$(ii) x + \frac{a^3}{b^2-a^2} \tan^{-1} \frac{x}{a} + \frac{b^3}{a^2-b^2} \tan^{-1} \frac{x}{b}.$$

$$19. \frac{1}{a^2+b^2} \left\{ \log \frac{x+b}{\sqrt{x^2+a^2}} + \frac{b}{a} \tan^{-1} \frac{x}{a} \right\}$$

$$20. (i) -\frac{1}{2} \log(1+x) + \frac{1}{4} \log(1+x^2) + \frac{1}{2} \tan^{-1} x.$$

$$(ii) \frac{1}{3} \log \frac{x-1}{\sqrt{x^2+x+1}} + \frac{1}{\sqrt{3}} \tan^{-1} \frac{2x+1}{\sqrt{3}}.$$

$$21. \frac{1}{2} [\log(x^2-x+1) - \log(x^2+x+1)].$$

$$22. (i) \left\{ \frac{1}{7} \log \frac{x-2}{x+2} + \frac{\sqrt{3}}{7} \tan^{-1} \frac{x}{\sqrt{3}} \right\}. \quad (ii) \frac{1}{8} \{\log(x^2-2) - \log(x^2+1)\}.$$

$$23. \frac{1}{2} \left\{ \tan^{-1}(x+2) + \frac{x+2}{x^2+4x+5} \right\}. \quad 24. \tan^{-1} x - \frac{1}{\sqrt{2}} \tan^{-1}(x\sqrt{2}).$$

$$25. \log x - \frac{1}{2} \log(1+x) - \frac{1}{4} \log(1+x^2) - \frac{1}{2} \tan^{-1} x.$$

$$26. \frac{1}{4} \log \frac{1+x+x^2}{1-x+x^2} + \frac{1}{2\sqrt{3}} \tan^{-1} \left(\frac{x\sqrt{3}}{1-x^2} \right).$$

$$27. (i) \frac{1}{4\sqrt{2}} \log \frac{1+x\sqrt{2}+x^2}{1-x\sqrt{2}+x^2} + \frac{1}{2\sqrt{2}} \tan^{-1} \left(\frac{x\sqrt{2}}{1-x^2} \right).$$

$$(ii) \frac{1}{\sqrt{2}} \tan^{-1} \frac{x\sqrt{2}}{1-x^2}.$$

$$28. (i) \frac{1}{8} \log \tan \left(\frac{1}{4}\pi + \frac{1}{2}x \right) - \frac{1}{10} \tan^{-1} \left(\frac{1}{2} \tan \frac{1}{2}x \right).$$

$$(ii) \frac{1}{8} \log(1+\cos x) + \frac{1}{2} \log(1-\cos x) - \frac{3}{8} \log(1-2\cos x).$$

$$29. (i) x + \log(1+e^x) - 2 \log(1+2e^x). \quad (ii) \frac{1}{4} \log(e^x-1)(e^x+3)^2.$$

$$30. -\frac{1}{2} \log(1+\cos x) + \frac{1}{10} \log(1-\cos x) + \frac{3}{8} \log(3+2\cos x).$$

CHAPTER VI
DEFINITE INTEGRALS

6.1. Thus far we have defined integration as *the inverse of differentiation*. Now, we shall define integration as a *process of summation*. In fact the integral calculus was invented in the attempt to calculate the area bounded by curves by supposing the given area to be divided into an infinite number of infinitesimal parts called elements, the sum of all these elements being the area required. Historically the integral sign is merely the long S used by early writers to denote the sum.

This new definition, as explained in the next article, is of a fundamental importance, because it is used in most of the applications of the integral calculus to practical problems.

6.2. Integration as the limit of a sum.

The generalised definition is given in Note 2 below. We first start with a special case of that definition which is advantageous for application in most cases.

Let $f(x)$ be a *bounded** *single-valued continuous function defined* in the interval (a, b) , a and b being both *finite quantities*, and $b > a$; and let the interval (a, b) be divided into n equal sub-intervals each of length h , by the points

$$a + h, a + 2h, \dots a + (n - 1)h, \text{ so that } nh = b - a;$$

**i.e.*, which does not become infinite at any point. See *Authors' Differential Calculus*.

then $\lim_{h \rightarrow 0} h [f(a) + f(a+h) + f(a+2h) + \cdots + f(a+n-1h)]$

i.e., shortly $\lim_{h \rightarrow 0} h \sum_{r=0}^{n-1} f(a+rh), (nh = b-a)$

or, $\lim_{n \rightarrow \infty} \frac{b-a}{n} \sum f\left(a + (b-a) \frac{r}{n}\right)$

($\because n \rightarrow \infty$ when $h \rightarrow 0$)

is defined as *the definite integral of $f(x)$ with respect to x between the limits a and b , and is denoted by the symbol*

$$\int_a^b f(x) dx.$$

' a ' is called the *lower or inferior limit*, and ' b ' is called the *upper or superior limit*.

Cor. Putting $a=0$, we get

$$\int_0^b f(x) dx = \lim_{h \rightarrow 0} h \sum_{r=0}^{n-1} f(rh), \text{ where, } nh = b.$$

Note 1. $\int_a^b f(x) dx$ is also sometimes defined as

$$\lim_{h \rightarrow 0} h \sum_{r=1}^n f(a+rh), \quad \text{or,} \quad \lim_{h \rightarrow 0} h \sum_{r=0}^n f(a+rh);$$

these definitions differ from one another only in the inclusion or exclusion of the terms $hf(a)$ and $hf(a+nh)$, i.e., $hf(b)$ which ultimately vanishes.

It should be carefully noted that whichever of these slightly different forms of the definition we use, we always arrive at the same result. Sometimes for the sake of simplicity we use one or other of these definitions.

Supposing the interval (a, b) to be divided into n equal parts each of length Δx by the points $x_0 (= a), x_1, x_2, \dots, x_n (= b)$, the definite

integral $\int_a^b f(x) dx$ may also be defined as $\lim_{n \rightarrow \infty} \sum_{r=0}^{n-1} f(x_r) \Delta x$.

Note 2. The above definition of a definite integral is a special case of the more generalised definition* as given below.

Let $f(x)$ be a bounded function defined in the interval (a, b) ; and let the interval (a, b) be divided in any manner into n sub-intervals (equal or unequal), of lengths $\delta_1, \delta_2, \dots, \delta_n$. In each sub-interval choose a perfectly arbitrary point (which may be within or at either end-point of the interval); and let these points be $x = \zeta_1, \zeta_2, \dots, \zeta_n$.

$$\text{Let } S_n = \sum_{r=1}^n \delta_r f(\zeta_r).$$

Now, let n increase indefinitely in such a way that the greatest of the lengths $\delta_1, \delta_2, \dots, \delta_n$ tends to zero. If in this case, S_n tends to a definite limit which is independent of the way in which the interval (a, b) is sub-divided and the intermediate points $\zeta_1, \zeta_2, \dots, \zeta_n$ are chosen, then this limit, when it exists, is called the definite integral of $f(x)$ from a to b .

It can be shown that when $f(x)$ is a continuous function, the above limit always exists.

In the present volume however, in Art. 6·4, we prove that if in addition to $f(x)$ being continuous in the interval, there exists a function of which it is the differential coefficient, then the above limit exists.

In the definition of the Article above, for the sake of simplicity, $f(x)$ is taken to be a continuous function, the intervals are taken to be of equal lengths, and $\zeta_1, \zeta_2, \dots, \zeta_n$ are taken as the end-points of the successive sub-intervals.

The method of unequal sub-divisions of the interval is illustrated in Ex. 5 below.

Ex. 1. Evaluate from first principles $\int_a^b e^x dx$. [C. P. 1922]

* For an alternative definition based on the concept of bounds, see Appendix.

From the definition,

$$\begin{aligned}
 \int_a^b e^x dx &= \lim_{h \rightarrow 0} h \sum_{r=0}^{n-1} e^{a+rh}, \text{ where } nh = b - a, \\
 &= \lim_{h \rightarrow 0} h [e^a + e^{a+h} + \dots + e^{a+(n-1)h}] \\
 &= \lim_{h \rightarrow 0} h \cdot e^a [1 + e^h + e^{2h} + \dots + e^{(n-1)h}] \\
 &= \lim_{h \rightarrow 0} h \cdot e^a \cdot \frac{e^{nh} - 1}{e^h - 1} \\
 &= e^a (e^{b-a} - 1) \cdot \lim_{h \rightarrow 0} \frac{h}{e^h - 1}, \text{ since } nh = b - a. \\
 &= e^b - e^a. \\
 &\quad \left[\text{since, } \lim_{h \rightarrow 0} \frac{h}{e^h - 1} = 1. \right]
 \end{aligned}$$

Ex. 2. Find from the definition, the value of

$$\int_0^1 x^2 dx. \quad [\text{C. P. 1935, '37}]$$

From the definition,

$$\begin{aligned}
 \int_0^1 x^2 dx &= \lim_{h \rightarrow 0} h \sum_{r=1}^n (rh)^2, \text{ where } nh = 1 \\
 &= \lim_{h \rightarrow 0} h [1^2 h^2 + 2^2 h^2 + \dots + n^2 h^2] \\
 &= \lim_{h \rightarrow 0} [h^3 (1^2 + 2^2 + \dots + n^2)] \\
 &= \lim_{h \rightarrow 0} h^3 \cdot \frac{n(n+1)(2n+1)}{6} \\
 &= \frac{1}{6} \cdot \lim_{h \rightarrow 0} [2n^3 h^3 + 3n^2 h^2 \cdot h + nh \cdot h^2] \\
 &= \frac{1}{6} \cdot \lim_{h \rightarrow 0} (2 + 3h + h^2), \text{ since } nh = 1 \\
 &= \frac{1}{6} \cdot 2 = \frac{1}{3}.
 \end{aligned}$$

Ex. 3 Prove *ab initio* $\int_a^b \frac{1}{x^2} dx = \frac{1}{a} - \frac{1}{b}$. [C. P. 1943]

Here, by the definition,

$$\int_a^b \frac{1}{x^2} dx = \lim_{h \rightarrow 0} h \left[\frac{1}{a^2} + \frac{1}{(a+h)^2} + \frac{1}{(a+2h)^2} + \dots + \frac{1}{(a+n-1h)^2} \right],$$

where $nh = b - a$.

Denoting the right-hand series by S , since, obviously,

$$\frac{1}{(a+rh)^2} \text{ is } > \frac{1}{(a+rh)(a+r+1h)} \text{ and } < \frac{1}{(a+r-1h)(a+rh)},$$

$$\text{we get } S > h \left[\frac{1}{a(a+h)} + \frac{1}{(a+h)(a+2h)} + \dots + \frac{1}{(a+n-1h)(a+nh)} \right],$$

$$\text{i.e., } > \left[\left(\frac{1}{a} - \frac{1}{a+h} \right) + \left(\frac{1}{a+h} - \frac{1}{a+2h} \right) + \dots + \left(\frac{1}{(a+n-1h)} - \frac{1}{(a+nh)} \right) \right]$$

$$\text{i.e., } > \left(\frac{1}{a} - \frac{1}{a+nh} \right) \text{ i.e., } > \frac{1}{a} - \frac{1}{b} \quad \left[\because nh = b - a \right],$$

$$\text{also } S < h \left[\frac{1}{(a-h)a} + \frac{1}{a(a+h)} + \dots + \frac{1}{(a+n-2h)(a+n-1h)} \right],$$

$$\text{i.e., } < \left[\left(\frac{1}{a-h} - \frac{1}{a} \right) + \left(\frac{1}{a} - \frac{1}{a+h} \right) + \dots + \left(\frac{1}{a+n-2h} - \frac{1}{a+n-1h} \right) \right],$$

$$\text{i.e., } < \left(\frac{1}{a-h} - \frac{1}{(a+n-1h)} \right), \text{ i.e., } < \left(\frac{1}{a-h} - \frac{1}{b-h} \right).$$

$$\text{Hence } \left(\frac{1}{a} - \frac{1}{b} \right) < S < \left(\frac{1}{a-h} - \frac{1}{b-h} \right),$$

and this being true for all values of h , proceeding to the limit when $h \rightarrow 0$, $\left(\frac{1}{a-h} - \frac{1}{b-h} \right)$ clearly tends to $\left(\frac{1}{a} - \frac{1}{b} \right)$, and S by definition becomes $\int_a^b \frac{dx}{x^2}$, and hence $\int_a^b \frac{dx}{x^2} = \frac{1}{a} - \frac{1}{b}$.

For an alternative method, see Ex. 5 ; here $m = -2$.

Ex. 4. Prove by summation, $\int_a^b \sin x \, dx = \cos a - \cos b$.

$$\begin{aligned}
 \int_a^b \sin x \, dx &= \lim_{h \rightarrow 0} h \sum_{r=0}^{n-1} \sin(a+rh), \text{ where } nh = b-a, \\
 &= \lim_{h \rightarrow 0} h [\sin a + \sin(a+h) + \sin(a+2h) + \dots \text{ to } n \text{ terms}], \\
 &= \lim_{h \rightarrow 0} h \cdot \sin \left\{ a + (n-1) \frac{h}{2} \right\} \frac{\sin \frac{1}{2}nh}{\sin \frac{1}{2}h} \\
 &= \lim_{h \rightarrow 0} \frac{\frac{1}{2}h}{\sin \frac{1}{2}h} \cdot 2 \sin \frac{1}{2}nh \cdot \sin \left\{ a + (n-1) \frac{h}{2} \right\} \\
 &= \lim_{h \rightarrow 0} \frac{\frac{1}{2}h}{\sin \frac{1}{2}h} \left[\cos \left(a - \frac{1}{2}h \right) - \cos \left\{ a + (2n-1) \frac{h}{2} \right\} \right] \\
 &= \lim_{h \rightarrow 0} [\cos(a - \frac{1}{2}h) - \cos(a + nh - \frac{1}{2}h)] \text{ since } \lim_{\theta \rightarrow 0} \frac{\theta}{\sin \theta} = 1 \\
 &= \lim_{h \rightarrow 0} [\cos(a - \frac{1}{2}h) - \cos(b - \frac{1}{2}h)], \text{ since } a + nh = b, \\
 &= \cos a - \cos b.
 \end{aligned}$$

Ex. 5. Evaluate $\int_a^b x^m \, dx$, where m is any number, positive or negative, integer or fraction, but $\neq -1$ ($0 < a < b$).

Let us divide the interval (a, b) into n parts by points of division $a, ar, ar^2, \dots, ar^{n-1}, ar^n$ where $ar^n = b$, i.e., $r = (b/a)^{\frac{1}{n}}$.

Evidently as $n \rightarrow \infty$, $r = (b/a)^{\frac{1}{n}} \rightarrow 1$, so that each of the intervals $a(r-1), ar(r-1), \dots, ar^{n-1}(r-1) \rightarrow 0$. Now, by the generalised definition, as given in Note 2, Art. 6'2,

$$\begin{aligned}
 \int_a^b x^m \, dx &= \lim_{n \rightarrow \infty} [a^m \cdot a(r-1) + (ar)^m \cdot ar(r-1) + (ar^2)^m \cdot (ar^2)(r-1) \\
 &\quad + \dots \text{ to } n \text{ terms}] \\
 &= \lim_{r \rightarrow 1} a^{m+1} (r-1) [1 + r^{m+1} + r^{2(m+1)} + \dots \text{ to } n \text{ terms}]
 \end{aligned}$$

$$\begin{aligned}
 &= \lim_{r \rightarrow 1} a^{m+1} (r-1) \cdot \frac{(r^{m+1})^n - 1}{r^{m+1} - 1} \quad [m+1 \neq 0] \\
 &= \lim_{r \rightarrow 1} a^{m+1} \cdot \frac{r-1}{r^{m+1} - 1} \cdot \{(r^n)^{m+1} - 1\} \\
 &= \lim_{r \rightarrow 1} \frac{r-1}{r^{m+1} - 1} \cdot a^{m+1} \cdot \left\{ \left(\frac{b}{a} \right)^{m+1} - 1 \right\} \\
 &= \lim_{r \rightarrow 1} \frac{r-1}{r^{m+1} - 1} \cdot (b^{m+1} - a^{m+1}) \\
 &= \frac{b^{m+1} - a^{m+1}}{m+1} \cdot [m \neq -1]
 \end{aligned}$$

$$\left[\because \lim_{r \rightarrow 1} \frac{r-1}{r^{m+1} - 1}, \text{ being of the form } \frac{0}{0} = \lim_{r \rightarrow 1} \frac{1}{(m+1)r^m} = \frac{1}{m+1} \right]$$

Note 1. Since x^m being continuous in (a, b) is integrable in (a, b) , a unique limit of the summation S_n as given in Note 2, Art. 6'2, exists ; so it is immaterial in what mode we calculate it. The same remark holds for the next example.

Note 2. In evaluating $\int_0^b x^m dx$ [$m \neq -1, b > 0$] we may first evaluate $\int_a^b x^m dx$ [$0 < a < b$] as above, and then make $a \rightarrow 0+$.

Ex. 6. Show from the definition

$$\int_a^b \frac{1}{x} dx = \log \frac{b}{a} \quad (0 < a < b)$$

As in Ex. 5, divide the interval (a, b) into n parts by points of division, $a, ar, ar^2, \dots, ar^{n-1}, ar^n$, where $ar^n = b$ i.e., $r = (b/a)^{1/n}$. Evidently as $n \rightarrow \infty, r = (b/a)^{1/n} \rightarrow 1$, so that each of the intervals $a(r-1), ar(r-1) \dots \rightarrow 0$. Now, by the generalised definition,

$$\begin{aligned}
 \int_a^b \frac{1}{x} dx &= \lim_{n \rightarrow \infty} \sum_{k=1}^n \frac{1}{ar^{k-1}} (ar^k - ar^{k-1}) \\
 &= \lim_{n \rightarrow \infty} \sum (r-1) = \lim_{n \rightarrow \infty} n(r-1)
 \end{aligned}$$

$$\begin{aligned}
&= \lim_{n \rightarrow \infty} \frac{1}{n} [(b/a)^{1/n} - 1] \\
&= \lim_{h \rightarrow 0} \left[\frac{e^h - 1}{h} \cdot \log \frac{b}{a} \right], \text{ where } h = \frac{1}{n} \log \frac{b}{a} \\
&= \log \frac{b}{a} \cdot \left[\because \lim_{h \rightarrow 0} \frac{e^h - 1}{h} = 1 \right]
\end{aligned}$$

Ex. 7. Find ab initio the value of $\int_0^{\frac{1}{2}\pi} \sec^2 x \, dx$.

By definition, the required integral

$$I = \lim_{h \rightarrow 0} \frac{1}{h} \sum_{r=1}^n \sec^2 rh, \text{ where } nh = \frac{1}{2}\pi.$$

Now, $\sec(r-1)h \sec rh < \sec^2 rh < \sec rh \sec(r+1)h$,

since $\sec x$ increases with x in $0 < x < \frac{1}{2}\pi$.

$$\begin{aligned}
\text{Also, } \sec rh \sec(r+1)h &= \frac{1}{\sin h} \cdot \frac{\sin\{(r+1)h - rh\}}{\cos rh \cos(r+1)h} \\
&= \frac{1}{\sin h} \{\tan(r+1)h - \tan rh\}.
\end{aligned}$$

Similarly, $\sec(r-1)h \sec rh$

$$= \frac{1}{\sin h} \{\tan rh - \tan(r-1)h\}.$$

Thus, I lies between $\lim_{h \rightarrow 0} \frac{1}{h} \sum_{r=1}^n \{\tan rh - \tan(r-1)h\}$

$$\text{and } \lim_{h \rightarrow 0} \frac{1}{h} \sum_{r=1}^n \{\tan(r+1)h - \tan rh\}$$

$$\text{i.e., } \lim_{h \rightarrow 0} \frac{1}{h} \sum_{r=1}^n \{\tan rh - \tan 0\} \text{ and } \lim_{h \rightarrow 0} \frac{1}{h} \sum_{r=1}^n \{\tan(n+1)h - \tan h\}.$$

Since $nh = \frac{1}{2}\pi$, and $\lim_{h \rightarrow 0} (h/\sin h) = 1$ as $h \rightarrow 0$, both the above limits tend to $\tan \frac{1}{2}\pi$, i.e., 1.

Hence, I has the value 1.

6.3. Geometrical Interpretation of $\int_a^b f(x) dx$.

Let the function $f(x)$, which we suppose to be finite and continuous in the interval (a, b) , $[b > a]$, be represented graphically and let $y = f(x)$ be the equation of the *continuous curve* PQ , and let AC , BD be two ordinates corresponding to the points $x = a$, $x = b$, meeting the curve at finite points.

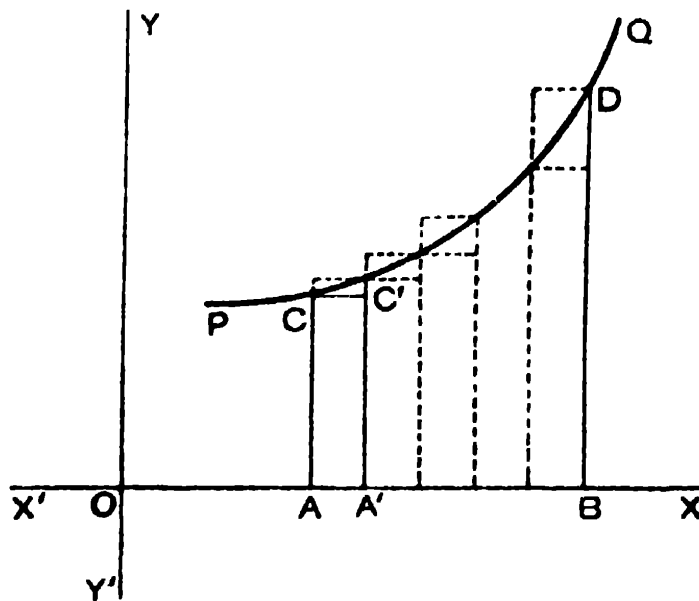

We have $OA = a$, $OB = b$ and $\therefore AB = b - a$.

Let AB be divided into n equal parts each of length h .

$\therefore nh = b - a$, or, $a + nh = b$.

Let the ordinates be erected through the points whose abscissæ are $a + h$, $a + 2h$, $a + (n - 1)h$ to meet the curve at finite points.

Let us complete the set of inner rectangles $ACC'A'$, and also the set of outer rectangles.

Let S denote the area enclosed between the curve $y = f(x)$, two ordinates $x = a$, $x = b$, and the x -axis.

Let S_1 denote the sum of the inner rectangles.

$\therefore S_1 < S$; $[f(x) \text{ monotone increasing}]$

$$\begin{aligned} \text{Now, } S_1 &= hf(a) + hf(a+h) + \cdots + hf(a + \overline{n-1}h) \\ &= h \sum_{r=0}^{n-1} f(a+rh). \end{aligned}$$

Let S_2 denote the sum of the outer rectangles ;

$$\therefore S_2 > S.$$

$$\begin{aligned} \text{Now, } S_2 &= hf(a+h) + hf(a+2h) + \cdots + hf(a+nh) \\ &= h \sum_{r=0}^{n-1} f(a+rh) - hf(a) + hf(b). \end{aligned}$$

We have, $S_1 < S < S_2$.

Now, let the number of sub-divisions increase indefinitely, and consequently the length of each of the sub-intervals diminishes indefinitely.

Thus, as $n \rightarrow \infty$, $h \rightarrow 0$.

\therefore both $hf(a)$ and $hf(b) \rightarrow 0$, since $f(a)$ and $f(b)$ are finite.

$$\therefore S_1 \rightarrow \lim_{h \rightarrow 0} h \sum_{r=0}^{n-1} f(a+rh) = \int_a^b f(x) dx.$$

$$S_2 \rightarrow \lim_{h \rightarrow 0} h \sum_{r=0}^{n-1} f(a+rh) = \int_a^b f(x) dx.$$

Since, we have always $S_1 < S < S_2$,

$$\therefore S = \int_a^b f(x) dx.$$

Thus, $\int_a^b f(x) dx$ geometrically represents the area of the space enclosed by the curve $y=f(x)$, the ordinates $x=a$, $x=b$, and the x -axis.

Note. The arguments here postulate a concave curve. Similar arguments apply for a convex curve, or even for a curve which alternately rises and falls in the interval.

6.4. Fundamental Theorem of Integral Calculus.

If $f(x)$ is integrable in (a, b) [$a < b$], and if there exists a function $\phi(x)$, such that $\phi'(x) = f(x)$ in (a, b) , then

$$\int_a^b f(x) dx = \phi(b) - \phi(a).$$

Divide the interval (a, b) into n parts by taking intermediate points,

$$a = x_0 < x_1 < x_2 < \dots < x_n = b.$$

Then we have, by the Mean Value Theorem of Differential Calculus,

$$\phi(x_r) - \phi(x_{r-1}) = (x_r - x_{r-1}) \phi'(\xi_r), \quad [x_{r-1} < \xi_r < x_r]$$

$$\therefore \sum_{r=0}^n \phi'(\xi_r) \delta_r = \sum [\phi(x_r) - \phi(x_{r-1})]$$

$$[\text{where } \delta_r = x_r - x_{r-1}]$$

$$= \phi(b) - \phi(a).$$

$\therefore \lim_{\delta \rightarrow 0} \sum \phi'(\xi_r) \delta_r = \phi(b) - \phi(a)$, where δ is the greatest of the sub-intervals δ_r . Since $f(x)$, and hence $\phi'(x)$ is integrable in (a, b) , therefore,

$$\lim_{\delta \rightarrow 0} \sum \phi'(\xi_r) \delta_r = \int_a^b \phi'(x) dx = \int_a^b f(x) dx.$$

$$\therefore \int_a^b f(x) dx = \phi(b) - \phi(a).$$

Note 1. The above theorem establishes a *connection between the integration as a particular kind of summation, and the integration as an operation inverse to differentiation.* This also establishes the existence of the limit of the sum referred to in Art. 6'2, Note 2. For an alternative proof of the theorem see Appendix.

Note 2. From the above theorem it is clear that *the definite integral is a function of its upper and lower limits* and not of the independent variable x .

Note 3. It should be noted that if the upper limit is the independent variable, the integral is not a definite integral but simply another form of the indefinite integral. Thus, suppose $\int f(x) dx = \phi(x)$; then

$$\int_a^x f(x) dx = \phi(x) - \phi(a) = \phi(x) + \text{a constant} = \int f(x) dx.$$

6'5. Evaluation of the Definite Integral.

By the help of the above theorem, the value of a definite integral can be obtained much more easily than by the tedious process of summation. The success in the evaluation of a definite integral by this method mainly depends upon the success in the evaluation of the corresponding indefinite integral, as will be seen from the following illustrative examples. The application of the above theorem in the evaluation of the definite integral is very simple.

Suppose we require to evaluate $\int_a^b f(x) dx$.

First evaluate the indefinite integral $\int f(x) dx$ by the usual methods, and suppose the result is $\phi(x)$.

Next substitute for x in $\phi(x)$ first the upper limit and then the lower limit, and subtract the last result from the first.

$$\text{Thus, } \int_a^b f(x) dx = \phi(b) - \phi(a).$$

Now, $\phi(b) - \phi(a)$ is very often shortly written as $\left[\phi(x) \right]_a^b$.

It should be carefully noted that *in a definite integral, the arbitrary constant of integration does not appear.*

For if we write $\int f(x) dx = \phi(x) + c = \psi(x)$ say,

$$\begin{aligned} \text{then } \int_a^b f(x) dx &= \psi(b) - \psi(a) = \{\phi(b) + c\} - \{\phi(a) + c\} \\ &= \phi(b) - \phi(a). \end{aligned}$$

Thus, *while evaluating a definite integral, arbitrary constant need not be added in the value of the corresponding indefinite integral.*

Illustrative Examples.

Ex. 1. Evaluate $\int_a^b x^n dx$.

$$\int x^n dx = \frac{x^{n+1}}{n+1}.$$

$$\therefore \int_a^b x^n dx = \left[\frac{x^{n+1}}{n+1} \right]_a^b = \frac{1}{n+1} [b^{n+1} - a^{n+1}]; \quad n+1 \neq 0.$$

Ex. 2. Evaluate $\int_0^{\frac{\pi}{2}} \cos^2 x dx$. [C. U. 1936]

$$\begin{aligned} \int \cos^2 x dx &= \frac{1}{2} \int 2 \cos^2 x dx = \frac{1}{2} \int (1 + \cos 2x) dx \\ &= \frac{1}{2} x + \frac{1}{4} \sin 2x. \end{aligned}$$

$$\begin{aligned} \therefore \int_0^{\frac{\pi}{2}} \cos^2 x dx &= \left[\frac{1}{2} x + \frac{1}{4} \sin 2x \right]_0^{\frac{\pi}{2}} \\ &= \frac{1}{4} \pi + \frac{1}{4} \sin \pi = \frac{1}{4} \pi. \end{aligned}$$

Ex. 3. Evaluate $\int_0^1 \frac{1-x}{1+x} dx$. [C. U. 1937]

$$\begin{aligned} \int \frac{1-x}{1+x} dx &= \int \left(\frac{2}{1+x} - 1 \right) dx \\ &= 2 \int \frac{1}{1+x} dx - \int dx = 2 \log(1+x) - x. \end{aligned}$$

$$\therefore I = \left[2 \log(1+x) - x \right]_0^1 = 2 \log 2 - 1 - 2 \log 1 = 2 \log 2 - 1.$$

Ex. 4. Evaluate $\int_0^a \frac{dx}{a^2+x^2}$.

$$\int \frac{dx}{a^2+x^2} = \frac{1}{a} \tan^{-1} \frac{x}{a}.$$

$$\begin{aligned} \therefore I &= \left[\frac{1}{a} \tan^{-1} \frac{x}{a} \right]_0^a = \frac{1}{a} \tan^{-1} 1 - \frac{1}{a} \tan^{-1} 0 \\ &= \frac{1}{a} \cdot \frac{\pi}{4} - \frac{1}{a} \cdot 0 = \frac{\pi}{4a}. \end{aligned}$$

Note. Two points should be noted when evaluating a definite integral for which the indefinite integral involves an inverse trigonometrical function.

(i) The result must never be expressed in degrees; for the ordinary rules for the differentiation and integration of trigonometrical functions hold only when the angles are measured in radians.

(ii) In substituting the limits in the inverse functions, care should be taken to choose the right values of the expressions obtained. Unless otherwise mentioned, usually the principal values are used.

6.6. Substitution in a Definite Integral.

While integrating an indefinite integral by the substitution of a new variable, it is sometimes rather troublesome

to transform the result back into the original variable. In all such cases, while integrating the corresponding integral between limits (*i.e.*, corresponding definite integral), we can avoid the tedious process of restoring the original variable, *by changing the limits of the definite integral to correspond with the change in the variable.*

Therefore in a definite integral the substitution should be effected in three places (i) in the integrand, (ii) in the differential and (iii) in the limits.

The following illustrative examples show the procedure to be employed.

Illustrative Examples.

Ex. 1. Evaluate $\int_0^1 \frac{\sin^{-1} x}{\sqrt{1-x^2}} dx$.

Put $\sin^{-1} x = \theta$. $\therefore d\theta = \frac{1}{\sqrt{1-x^2}} dx$.

0 and 1 are the limits of x ; the corresponding limits of θ where $\theta = \sin^{-1} x$ are found as follows :

When $x=0$, $\theta = \sin^{-1} 0 = 0$.

When $x=1$, $\theta = \sin^{-1} 1 = \frac{1}{2}\pi$.

$$\int_0^{\frac{\pi}{2}} \theta d\theta = \left[\frac{1}{2} \theta^2 \right]_0^{\frac{\pi}{2}} = \frac{1}{8} \pi^2.$$

Note. Of course this example can be worked out by first finding the indefinite integral in terms of x and then substituting the limits.

Ex. 2. Evaluate $\int_0^a \sqrt{a^2 - x^2} dx$.

Put $x = a \sin \theta$. $\therefore dx = a \cos \theta d\theta$.

Also, when $x = 0$, $\theta = 0$, and when $x = a$, $\theta = \frac{1}{2}\pi$.

$$\therefore I = \int_0^{\frac{1}{2}\pi} a^2 \cos^2 \theta d\theta = a^2 \int_0^{\frac{1}{2}\pi} \cos^2 \theta d\theta.$$

$$\text{Now, } \int \cos^2 \theta d\theta = \frac{1}{2} \int (1 + \cos 2\theta) d\theta = \frac{1}{2} \left[\theta + \frac{1}{2} \sin 2\theta \right].$$

$$\therefore I = a^2 \cdot \frac{1}{2} \left[\theta + \frac{1}{2} \sin 2\theta \right]_0^{\frac{1}{2}\pi} = \frac{1}{4} \pi a^2.$$

Ex. 3. Evaluate $\int_a^\beta \sqrt{(x-a)(\beta-x)} dx$. [C. P. 1925, '32, '37]

Put $x = a \cos^2 \theta + \beta \sin^2 \theta$. $\therefore dx = 2(\beta - a) \sin \theta \cos \theta d\theta$;

also, $x - a = \beta \sin^2 \theta - a(1 - \cos^2 \theta) = (\beta - a) \sin^2 \theta$.

$$\beta - x = \beta(1 - \sin^2 \theta) - a \cos^2 \theta = (\beta - a) \cos^2 \theta.$$

\therefore when $x = a$, $(\beta - a) \sin^2 \theta = 0$.

$\therefore \sin \theta = 0$. $\therefore \theta = 0$, since $\beta \neq a$.

Similarly, when $x = \beta$, $(\beta - a) \cos^2 \theta = 0$.

$\therefore \cos \theta = 0$. $\therefore \theta = \frac{1}{2}\pi$.

$$\therefore I = 2(\beta - a)^2 \int_0^{\frac{\pi}{2}} \sin^2 \theta \cos^2 \theta d\theta.$$

Now, $\sin^2 \theta \cos^2 \theta = \frac{1}{4} \cdot 4 \sin^2 \theta \cos^2 \theta = \frac{1}{4} \sin^2 2\theta = \frac{1}{8} (1 - \cos 4\theta)$.

$$\text{Also, } \int (1 - \cos 4\theta) d\theta = \theta - \frac{1}{4} \sin 4\theta.$$

$$\begin{aligned} \therefore I &= 2(\beta - a)^2 \frac{1}{8} \int_0^{\frac{\pi}{2}} (1 - \cos 4\theta) d\theta = \frac{1}{4} (\beta - a)^2 \cdot \left[\theta - \frac{1}{4} \sin 4\theta \right]_0^{\frac{\pi}{2}} \\ &= \frac{1}{4} (\beta - a)^2 \left[\frac{1}{2}\pi - \frac{1}{4} \sin 2\pi \right] = \frac{1}{8} \pi (\beta - a)^2. \end{aligned}$$

Ex. 4. Evaluate $\int_a^\beta \frac{dx}{\sqrt{(x-a)(\beta-x)}} \quad (\beta > a)$

As in Ex. 3, put $x = a \cos^2 \theta + \beta \sin^2 \theta$.

$$\therefore I = \int_0^{\frac{1}{2}\pi} 2d\theta = 2 \cdot \frac{1}{2} \pi = \pi.$$

Ex. 5. Show that $\int_0^{\frac{1}{2}} \frac{dx}{(1-2x^2)\sqrt{1-x^2}} = \frac{1}{2} \log(2 + \sqrt{3})$.

[C. P. 1933]

Put $x = \sin \theta$. Then $dx = \cos \theta d\theta$; also when $x=0$, $\theta=0$, and when $x = \frac{1}{2}$, $\theta = \frac{1}{6}\pi$.

$$\begin{aligned} \therefore I &= \int_0^{\frac{1}{2}\pi} \frac{\cos \theta d\theta}{\cos 2\theta \cos \theta} = \int_0^{\frac{1}{2}\pi} \sec 2\theta d\theta \\ &= \left[\frac{1}{2} \log \tan \left(\frac{1}{4}\pi + \theta \right) \right]_0^{\frac{\pi}{6}} \\ &= \frac{1}{2} [\log \tan \frac{1}{4}\pi - \log \tan \frac{1}{4}\pi] = \frac{1}{2} \log(2 + \sqrt{3}). \end{aligned}$$

Ex. 6. Show that $\int_0^{\frac{1}{2}\pi} \sin^6 \theta \cos^3 \theta d\theta = \frac{2}{63}$. [C. P. 1925]

Let $\sin \theta = x$. $\therefore \cos \theta d\theta = dx$;

also when $\theta=0$, $x=0$ and when $\theta = \frac{1}{2}\pi$, $x=1$.

$$\begin{aligned} \therefore I &= \int_0^{\frac{1}{2}\pi} \sin^6 \theta (1 - \sin^2 \theta) \cdot \cos \theta d\theta = \int_0^1 x^6 (1 - x^2) dx \\ &= \int_0^1 x^6 dx - \int_0^1 x^8 dx = \left[\frac{x^7}{7} \right]_0^1 - \left[\frac{x^9}{9} \right]_0^1 = \frac{1}{7} - \frac{1}{9} = \frac{2}{63}. \end{aligned}$$

6.7. Series represented by Definite Integrals.

The definition of the definite integral as the limit of a sum enables us to evaluate easily the limits of the sums

of certain series, when the number of terms tends to infinity by identifying them with some definite integrals. This is illustrated by the following examples.

In identifying a series with a definite integral, it should be noted that the definite integral

$$\int_a^b f(x) dx = \lim_{h \rightarrow 0} h \sum f(a + rh), \text{ when } nh = b - a,$$

may be expressed as

$$\lim_{n \rightarrow \infty} \frac{b-a}{n} \sum f\left(a + r \frac{b-a}{n}\right) = \int_a^b f(x) dx.$$

In the special case when $a = 0$, $b = 1$, we have $h = 1/n$.

Hence, in this case, we have

$$\lim_{n \rightarrow \infty} \frac{1}{n} \sum f\left(\frac{r}{n}\right) = \int_0^1 f(x) dx$$

[As if we write x for r/n and dx for $1/n$.]

or putting $h = 1/n$, $\lim_{h \rightarrow 0} h \sum f(rh) = \int_0^1 f(x) dx.$

[As if we write x for rh and dx for h .]

Ex. 1. Evaluate $\lim_{n \rightarrow \infty} \left\{ \frac{1}{n+1} + \frac{1}{n+2} + \dots + \frac{1}{n+n} \right\}.$

Dividing the numerator and denominator of each term of the above series by n , the given series becomes

$$\begin{aligned} &= \lim_{n \rightarrow \infty} \left\{ \frac{1}{n} \left(\frac{1}{1 + \frac{1}{n}} + \frac{1}{1 + \frac{2}{n}} + \dots + \frac{1}{1 + \frac{n}{n}} \right) \right\} \\ &= \lim_{n \rightarrow \infty} \frac{1}{n} \cdot \sum_{r=1}^n \frac{1}{1 + \frac{r}{n}} = \lim_{h \rightarrow 0} h \sum_{r=1}^n \frac{1}{1 + rh} \quad \left[\text{putting } h = \frac{1}{n} \right] \\ &= \int_0^1 \frac{1}{1+x} dx = \left[\log(1+x) \right]_0^1 = \log 2. \end{aligned}$$

Ex. 2. Evaluate

$$Lt_{n \rightarrow \infty} \left\{ \left(1 + \frac{1}{n^2}\right)^2 \left(1 + \frac{2^2}{n^2}\right)^4 \left(1 + \frac{3^2}{n^2}\right)^6 \cdots \left(1 + \frac{n^2}{n^2}\right)^{2n} \right\}.$$

Let A denote the given expression ; then

$$\log A = \sum_{r=1}^n \frac{2r}{n^2} \log \left(1 + \frac{r^2}{n^2}\right).$$

$$\begin{aligned} \therefore Lt_{n \rightarrow \infty} \log A &= Lt_{n \rightarrow \infty} \frac{1}{n} \sum_{r=1}^n 2 \frac{r}{n} \log \left(1 + \frac{r^2}{n^2}\right) \\ &= \int_0^1 2x \log (1+x^2) dx \\ &= \int_1^2 \log z dz. \quad [\text{putting } 1+x^2=z] \\ &= \left[z \log z - z \right]_1^2 = 2 \log 2 - 1 = \log \frac{4}{e}. \end{aligned}$$

Since, $\log Lt_{n \rightarrow \infty} A = Lt_{n \rightarrow \infty} \log A = \log \frac{4}{e}$,

$\therefore Lt_{n \rightarrow \infty} A$, i.e., the limit = $\frac{4}{e}$.

Ex. 3. Prove that $Lt_{n \rightarrow \infty} \frac{1^m + 2^m + 3^m + \cdots + n^m}{n^{m+1}} = \frac{1}{m+1} [m > -1]$.

Left side

$$\begin{aligned} &= Lt_{n \rightarrow \infty} \frac{1}{n} \left[\left(\frac{1}{n}\right)^m + \left(\frac{2}{n}\right)^m + \cdots + \left(\frac{n}{n}\right)^m \right] \\ &= Lt_{n \rightarrow \infty} \frac{1}{n} \sum_{r=1}^n \left(\frac{r}{n}\right)^m = Lt_{h \rightarrow 0} h \sum_{r=1}^n \left(\frac{r}{h}\right)^m \left[\text{where } h = \frac{1}{n} \right] \\ &= \int_0^1 x^m dx = \left[\frac{x^{m+1}}{m+1} \right]_0^1 \\ &= \frac{1}{m+1}. \end{aligned}$$

EXAMPLES VI(A)

1. Find by the method of summation the values of :—

$$(i) \int_a^b e^{-x} dx.$$

$$(ii) \int_a^b e^{kx} dx.$$

$$(iii) \int_0^1 x^3 dx.$$

$$(iv) \int_0^1 (ax + b) dx.$$

$$(v) \int_0^{\frac{1}{2}\pi} \sin x dx.$$

$$(vi) \int_a^b \cos \theta d\theta.$$

$$(vii) \int_0^1 \sqrt{x} dx.$$

$$(viii) \int_1^4 \frac{1}{\sqrt{x}} dx.$$

$$(ix) \int_0^a \sin nx dx.$$

$$(x) \int_{\frac{1}{2}\pi}^{\frac{3}{2}\pi} \operatorname{cosec}^2 x dx.$$

Evaluate the following integrals (*Ex. 2 to Ex. 12*) :—

$$2. (i) \int_0^1 x^3 \sqrt{1+3x^4} dx.$$

$$(ii) \int_0^{2a} \sqrt{2ax-x^2} dx.$$

$$(iii) \int_1^{e^2} \frac{dx}{x(1+\log x)^2}.$$

$$(iv) \int_0^1 \frac{dx}{(x^2+1)^2}.$$

$$3. \int_0^1 xe^x dx.$$

[*C. P. 1936*]

$$4. (i) \int_0^1 \sin^{-1} x dx.$$

$$(ii) \int_0^1 \tan^{-1} x dx.$$

$$(iii) \int_0^1 (\cos^{-1} x)^2 dx.$$

$$(iv) \int_0^1 x \log(1+2x) dx.$$

$$(v) \int_0^1 x(\tan^{-1} x)^2 dx.$$

$$(vi) \int_0^1 x^2 \sqrt{4-x^2} dx.$$

$$5. (i) \int_0^{\pi} \sin mx \sin nx \, dx. \quad [C. P. 1937]$$

$$(ii) \int_0^{\pi} \cos mx \cos nx \, dx. \quad (m, n \text{ being integers })$$

$$(iii) \int_0^{\frac{1}{2}\pi} \sin x \sin 2x \, dx. \quad [C. P. 1940]$$

$$6. (i) \int_0^{\pi} \sin^2 nx \, dx. \quad (ii) \int_0^{\pi} \cos^2 nx \, dx.$$

(n being an integer)

$$7. (i) \int_0^1 \frac{x \, dx}{\sqrt{1+x^2}}. \quad (ii) \int_0^a \frac{dx}{(a^2+x^2)^{\frac{3}{2}}}.$$

$$(iii) \int_0^a \frac{dx}{\sqrt{ax-x^2}}. \quad (iv) \int_2^3 \frac{dx}{\sqrt{(x-1)(5-x)}}.$$

$$8. (i) \int_0^{\frac{1}{2}\pi} x \sin x \, dx. \quad (ii) \int_0^{\frac{1}{2}\pi} \sec x \, dx.$$

$$(iii) \int_0^{\frac{1}{2}\pi} (\sec \theta - \tan \theta) \, d\theta.$$

$$9. (i) \int_0^{\frac{1}{2}\pi} \tan x \, dx. \quad (ii) \int_0^{\frac{1}{2}\pi} \tan^2 x \, dx.$$

$$10. (i) \int_0^{\frac{1}{2}\pi} \cos 2x \cos 3x \, dx. \quad (ii) \int_0^{\frac{1}{2}\pi} \sin^2 x \cos^3 x \, dx.$$

$$(iii) \int_0^{\frac{1}{2}\pi} x \cos x \cos 3x \, dx. \quad (iv) \int_0^{\frac{1}{2}\pi} \sec^4 \theta \, d\theta.$$

$$11. \text{ (i) } \int_1^{e^e} x \log x \, dx. \quad \text{(ii) } \int_0^{\frac{1}{2}\pi} x^2 \sin x \, dx.$$

$$\text{(iii) } \int_0^{\frac{1}{2}\pi} \sin \phi \cos \phi \sqrt{(a^2 \sin^2 \phi + b^2 \cos^2 \phi)} d\phi.$$

$$12. \text{ (i) } \int_0^a \frac{dx}{a^2 + x^2}. \quad \text{(ii) } \int_1^2 \frac{dx}{x(1+2x)^2}.$$

$$\text{(iii) } \int_0^{\frac{1}{2}\pi} \frac{dx}{a + b \cos x} \quad (a > b > 0).$$

$$\text{(iv) } \int_0^\pi \frac{dx}{1 - 2a \cos x + a^2} \quad (0 < a < 1).$$

Show that :—

$$13. \int_0^{\log 2} \frac{e^x}{1 + e^x} dx = \log \frac{3}{2}.$$

$$14. \int_a^b \frac{\log x}{x} dx = \frac{1}{2} \log \left(\frac{b}{a} \right) \log (ab).$$

$$15. \int_0^a \sin^{-1} \frac{2t}{1+t^2} dt = 2a \tan^{-1} a - \log (1 + a^2).$$

$$16. \text{ (i) } \int_1^2 \sqrt{(x-1)(2-x)} dx = \frac{1}{8}\pi.$$

$$\text{(ii) } \int_8^{15} \frac{dx}{(x-3)\sqrt{x+1}} = \frac{1}{2} \log \frac{5}{3}.$$

$$17. \int_0^a \frac{a^2 - x^2}{(a^2 + x^2)^2} dx = \frac{1}{2a}.$$

$$18. \int_0^{\frac{1}{2}\pi} \frac{\sin x \, dx}{1 + \cos^2 x} = \frac{\pi}{4} + \tan^{-1} \frac{1}{\sqrt{2}}.$$

$$19. \int_0^{\frac{1}{2}\pi} \cos^3 x \sqrt[4]{\sin x} \, dx = \frac{3}{8} \frac{\pi}{5}.$$

$$20. (i) \int_0^{\frac{1}{2}\pi} \frac{dx}{a^2 \cos^2 x + b^2 \sin^2 x} = \frac{\pi}{2ab} \quad [a, b > 0]$$

$$(ii) \int_0^{\frac{1}{2}\pi} \frac{\sin^2 x \cos^2 x}{(\sin^3 x + \cos^3 x)^2} dx = \frac{1}{6}.$$

$$21. (i) \int_0^{\frac{1}{2}\pi} \frac{dx}{4 + 5 \sin x} = \frac{1}{3} \log 2.$$

$$(ii) \int_0^{\frac{1}{2}\pi} \frac{dx}{5 + 4 \sin x} = \frac{2}{3} \tan^{-1} \frac{1}{3}.$$

$$22. (i) \int_0^{\frac{1}{2}\pi} \frac{dx}{5 + 3 \cos x} = \frac{1}{2} \tan^{-1} \frac{1}{2}.$$

$$(ii) \int_0^{\frac{1}{2}\pi} \frac{dx}{3 + 5 \cos x} = \frac{1}{4} \log 3.$$

$$(iii) \int_0^{\frac{1}{2}\pi} \frac{dx}{1 + 4 \cot^2 x} = \frac{\pi}{6}.$$

$$23. \int_0^{\frac{1}{2}\pi} \frac{dx}{1 + \cos \theta \cos x} = \frac{\theta}{\sin \theta}.$$

$$24. \int_0^{\frac{1}{2}\pi} \frac{\cos x dx}{(1 + \sin x)(2 + \sin x)} = \log \frac{4}{3}.$$

$$25. \int_0^{\frac{1}{2}\pi} \frac{\sin 2x}{\sin^4 x + \cos^4 x} dx = \frac{\pi}{4}.$$

$$26. (i) \int_0^{\frac{1}{2}\pi} \frac{dx}{(a^2 \cos^2 x + b^2 \sin^2 x)^2} = \frac{\pi}{4} \cdot \frac{a^2 + b^2}{a^3 b^3} \quad [a, b > 0]$$

[Multiply num. and denom. by $\sec^4 x$; then put $b \tan x = a \tan \theta$]

$$(ii) \int_0^{\frac{1}{2}\pi} \frac{x \sin x \cos x}{(a^2 \cos^2 x + b^2 \sin^2 x)^2} dx = \frac{\pi}{4ab^2(a+b)} \quad [a, b > 0]$$

$$27. \int_2^e \left\{ \frac{1}{\log x} - \frac{1}{(\log x)^2} \right\} dx = e - \frac{2}{\log 2}.$$

$$28. (i) \int_2^3 \frac{dx}{(x-1)\sqrt{x^2-2x}} = \frac{\pi}{3}.$$

$$(ii) \int_0^1 \frac{dx}{(1+x)\sqrt{1+2x-x^2}} = \frac{\pi}{4\sqrt{2}}.$$

29. Evaluate the following :—

$$(i) \operatorname{Lt}_{n \rightarrow \infty} \left[\frac{1}{n+m} + \frac{1}{n+2m} + \dots + \frac{1}{n+nm} \right].$$

$$(ii) \operatorname{Lt}_{n \rightarrow \infty} \left[\frac{n}{n^2+1^2} + \frac{n}{n^2+2^2} + \dots + \frac{n}{n^2+n^2} \right].$$

$$(iii) \operatorname{Lt}_{n \rightarrow \infty} \left[\frac{1}{\sqrt{n^2-1^2}} + \frac{1}{\sqrt{n^2-2^2}} + \dots + \frac{1}{\sqrt{n^2-(n-1)^2}} \right].$$

$$(iv) \operatorname{Lt}_{n \rightarrow \infty} \left[\frac{1}{\sqrt{2n-1^2}} + \frac{1}{\sqrt{4n-2^2}} + \dots + \frac{1}{n} \right].$$

[Write $n = \sqrt{2n^2 - n^2}$ in the last term]

$$(v) \operatorname{Lt}_{n \rightarrow \infty} \left[\frac{1^2}{n^3+1^3} + \frac{2^2}{n^3+2^3} + \dots + \frac{n^2}{2n^3} \right].$$

$$(vi) \operatorname{Lt}_{n \rightarrow \infty} \left[\frac{1}{n} + \frac{n^2}{(n+1)^3} + \frac{n^2}{(n+2)^3} + \dots + \frac{1}{8n} \right].$$

$$(vii) \operatorname{Lt}_{n \rightarrow \infty} \left[\frac{1}{n} + \frac{\sqrt{n^2-1^2}}{n^2} + \dots + \frac{\sqrt{n^2-(n-1)^2}}{n^2} \right].$$

$$(viii) \operatorname{Lt}_{n \rightarrow \infty} \sum_{r=1}^{n-1} \frac{1}{n} \sqrt{\left(\frac{n+r}{n-r}\right)}.$$

$$(ix) \operatorname{Lt}_{n \rightarrow \infty} \left\{ \left(1 + \frac{1}{n}\right) \left(1 + \frac{2}{n}\right) \dots \left(1 + \frac{n}{n}\right) \right\}^{\frac{1}{n}}.$$

$$(x) \operatorname{Lt}_{n \rightarrow \infty} \left\{ \left(1 + \frac{1^2}{n^2}\right) \left(1 + \frac{2^2}{n^2}\right) \dots \left(1 + \frac{n^2}{n^2}\right) \right\}^{\frac{1}{n}}.$$

$$(xi) \lim_{n \rightarrow \infty} \sum_{r=1}^n \frac{n+r}{n^2+r^2}.$$

$$(xii) \lim_{n \rightarrow \infty} \sum_{r=1}^n \frac{n}{(n+r) \sqrt{r(2n+r)}}.$$

$$(xiii) \lim_{n \rightarrow \infty} \left[\frac{1}{n} + \frac{1}{n+1} + \frac{1}{n+2} + \dots + \frac{1}{3n} \right].$$

$$(xiv) \lim_{n \rightarrow \infty} \frac{1}{\sqrt{n}} \left[1 + \frac{1}{\sqrt{2}} + \dots + \frac{1}{\sqrt{n}} \right].$$

$$(xv) \lim_{n \rightarrow \infty} \left[\frac{\sqrt{(n+1)} + \sqrt{(n+2)} + \dots + \sqrt{2n}}{n \sqrt{n}} \right].$$

$$(xvi) \lim_{n \rightarrow \infty} \left[\frac{n!}{n^n} \right]^{1/n}.$$

30. If $\int_0^a \frac{dx}{\sqrt{x+a} + \sqrt{x}} = \int_0^{2\pi} \frac{\sin \theta d\theta}{\cos^2 \theta}$

find the value of a .

31. If a be positive and the positive value of the square root is taken, show that

$$\int_{-1}^{+1} \frac{dx}{\sqrt{(1-2ax+a^2)}} = \begin{cases} 2 & \text{if } a < 1; \\ \frac{2}{a} & \text{if } a > 1. \end{cases}$$

32. If m and n are positive integers, show that

$$(i) \int_{-\pi}^{+\pi} \sin mx \sin nx dx = \begin{cases} 0 & \text{if } m \neq n \\ \pi & \text{if } m = n. \end{cases}$$

$$(ii) \int_{-\pi}^{+\pi} \sin mx \cos nx dx = 0.$$

$$(iii) \int_{-\pi}^{+\pi} \cos mx \cos nx dx = \begin{cases} 0 & \text{if } m \neq n \\ \pi & \text{if } m = n. \end{cases}$$

ANSWERS

1. (i) $(e^{-a} - e^{-b})$. (ii) $(e^{kb} - e^{ka})/k$. (iii) $\frac{1}{2}$. (iv) $\frac{1}{2}a + b$.
 (v) 1. (vi) $\sin b - \sin a$. (vii) $\frac{2}{3}$. (viii) 2.
 (ix) $(1 - \cos na)/n$. (x) 1.
2. (i) $\frac{7}{18}$. (ii) $\frac{1}{2}\pi a^2$. (iii) $\frac{2}{3}$. (iv) $\frac{1}{2}(\pi + 2)$.
3. 1. 4. (i) $\frac{1}{2}\pi - 1$. (ii) $\frac{1}{4}\pi - \frac{1}{2}\log 2$. (iii) $\pi - 2$. (iv) $\frac{2}{3}\log 3$.
 (v) $\frac{1}{2}\pi(\frac{1}{2}\pi - 1) + \frac{1}{2}\log 2$. (vi) $\frac{1}{2}\pi - \frac{1}{2}\sqrt{3}$.
5. (i) $\frac{\sin(m-n)\pi}{2(m-n)} - \frac{\sin(m+n)\pi}{2(m+n)}$. (ii) 0. (iii) $\frac{2}{3}$.
6. (i) $\frac{1}{2}\pi$. (ii) $\frac{1}{2}\pi$. 7. (i) $\sqrt{2} - 1$. (ii) $\frac{1}{a^2\sqrt{2}}$. (iii) π .
 (iv) $\frac{1}{8}\pi$. 8. (i) 1. (ii) $\log(\sqrt{2} + 1)$. (iii) $\log 2$. 9. (i) $\frac{1}{2}\log 2$.
 (ii) $1 - \frac{1}{4}\pi$. 10. (i) $\frac{2}{3}$. (ii) $\frac{2}{15}$. (iii) $\frac{1}{18}(\pi - 3)$. (iv) $\frac{4}{3}$.
11. (i) $\frac{1}{2}$. (ii) $\pi - 2$. (iii) $\frac{1}{3} \cdot \frac{a^2 + ab + b^2}{a + b}$.
12. (i) $\frac{\pi}{4a}$. (ii) $\log \frac{6}{5} - \frac{2}{15}$.
- (iii) $\frac{1}{\sqrt{a^2 - b^2}} \cos^{-1} \left(\frac{b}{a} \right)$. (iv) $\frac{\pi}{1 - a^2}$. 29. (i) $\frac{1}{m} \log(1 + m)$.
 (ii) $\frac{1}{4}\pi$. (iii) $\frac{1}{2}\pi$. (iv) $\frac{1}{2}\pi$. (v) $\frac{1}{3}\log 2$. (vi) $\frac{2}{3}$.
 (vii) $\frac{1}{4}\pi$. (viii) $\frac{1}{2}\pi + 1$. (ix) $4/e$.
- (x) $2e^{\frac{1}{2}(\pi - 4)}$. (xi) $\frac{\pi}{4} + \frac{1}{2}\log 2$. (xii) $\frac{1}{3}\pi$. (xiii) $\log_e 3$.
 (xiv) 2. (xv) $\frac{4}{3}\sqrt{2} - \frac{2}{3}$. (xvi) e^{-1} . 30. $\frac{9}{18}$.

6·8. General Properties of Definite Integrals.

$$(i) \int_a^b f(x) dx = \int_a^b f(z) dz.$$

$$\text{Let } \int f(x) dx = \phi(x); \quad \therefore \int_a^b f(x) dx = \phi(b) - \phi(a);$$

$$\text{then, } \int f(z) dz = \phi(z); \quad \therefore \int_a^b f(z) dz = \phi(b) - \phi(a).$$

$$(ii) \int_a^b f(x) dx = - \int_b^a f(x) dx.$$

$$\text{Let } \int f(x) dx = \phi(x); \quad \therefore \int_a^b f(x) dx = \phi(b) - \phi(a),$$

$$\text{and } - \int_b^a f(x) dx = -[\phi(a) - \phi(b)] = \phi(b) - \phi(a).$$

Thus, an interchange of limits changes the sign of the integral.

$$(iii) \int_a^b f(x) dx = \int_a^c f(x) dx + \int_c^b f(x) dx. \quad (a < c < b).$$

$$\text{Let } \int f(x) dx = \phi(x); \quad \therefore \int_a^b f(x) dx = \phi(b) - \phi(a).$$

$$\text{Right side} = \{\phi(c) - \phi(a)\} + \{\phi(b) - \phi(c)\} = \phi(b) - \phi(a).$$

Generalisation.

$$\begin{aligned} \int_a^b f(x) dx &= \int_a^{c_1} f(x) dx + \int_{c_1}^{c_2} f(x) dx + \dots \\ &\quad + \int_{c_{n-1}}^{c_n} f(x) dx + \int_{c_n}^b f(x) dx \end{aligned}$$

when $a < c_1 < c_2 < \dots < c_n < b$.

$$(iv) \int_0^a f(x) dx = \int_0^a f(a-x) dx.$$

Proof. Put $a-x=z$, $\therefore dx = -dz$;

also when $x=0$, $z=a$, and when $x=a$, $z=0$.

$$\therefore \text{right side} = - \int_a^0 f(z) dz = \int_0^a f(z) dz = \int_0^a f(x) dx.$$

$$\text{Illustration : } \int_0^{\frac{\pi}{2}} \sin x dx = \int_0^{\pi} \sin\left(\frac{\pi}{2} - x\right) dx = \int_0^{\frac{\pi}{2}} \cos x dx.$$

$$(v) \int_0^{na} f(x) dx = n \int_0^a f(x) dx, \text{ if } f(x) = f(a+x).$$

Proof.

$$\int_0^{na} f(x) dx = \int_0^a f(x) dx + \int_a^{2a} f(x) dx + \cdots + \int_{(n-1)a}^{na} f(x) dx.$$

Put $z+a=x$, then, $dx = dz$,

also when $x=a$, $z=0$, and when $x=2a$, $z=a$;

$$\begin{aligned} \therefore \int_a^{2a} f(x) dx &= \int_0^a f(z+a) dz = \int_0^a f(a+x) dx \\ &= \int_0^a f(x) dx. \end{aligned}$$

Similarly, it can be shown that

$$\int_{2a}^{3a} f(x) dx = \int_a^{2a} f(x) dx = \int_0^a f(x) dx ;$$

and so on. Thus, each of the integrals on the right side

can be shown to be equal to $\int_0^a f(x) dx$. Hence, the result.

Illustration :

Since, $\sin^2 x = \sin^2 (\pi - x)$, $\therefore \int_0^{2\pi} \sin^2 x \, dx = 4 \int_0^{\pi} \sin^2 x \, dx$.

$$(vi) \int_0^{2a} f(x) \, dx = \int_0^a f(x) \, dx + \int_0^a f(2a - x) \, dx.$$

$$\text{Proof. } \int_0^{2a} f(x) \, dx = \int_0^a f(x) \, dx + \int_a^{2a} f(x) \, dx. \quad [\text{By (iii)}]$$

Put $x = 2a - z$ in the 2nd integral ; then, $dx = -dz$,
also when $x = a$, $z = a$; and when $x = 2a$, $z = 0$.

\therefore the second integral on the right side *viz.*

$$\begin{aligned} \int_a^{2a} f(x) \, dx &= - \int_a^0 f(2a - z) \, dz = \int_0^a f(2a - z) \, dz \\ & \quad [\text{By (ii)}] \\ &= \int_0^a f(2a - x) \, dx. \quad [\text{By (i)}] \end{aligned}$$

Hence the result.

$$(vii) \int_0^{2a} f(x) \, dx = 2 \int_0^a f(x) \, dx, \text{ if } f(2a - x) = f(x),$$

$$\text{and } \int_0^{2a} f(x) \, dx = 0, \text{ if } f(2a - x) = -f(x).$$

These two results follow immediately from (vi).

Illustration :

Since, $\sin (\pi - x) = \sin x$, and $\cos (\pi - x) = -\cos x$,

$$\therefore \int_0^{\pi} \sin x \, dx = 2 \int_0^{\frac{\pi}{2}} \sin x \, dx ; \text{ and } \int_0^{\pi} \cos x \, dx = 0,$$

$$\text{and generally } \int_0^{\pi} f(\sin x) \, dx = 2 \int_0^{\frac{\pi}{2}} f(\sin x) \, dx,$$

$$\text{and } \int_0^{\pi} f(\cos x) \, dx = 0, \text{ if } f(\cos x) \text{ is an odd function of } \cos x.$$

$$(viii) \int_{-a}^{+a} f(x) dx = \int_0^a \{f(x) + f(-x)\} dx.$$

$$Proof. \int_{-a}^{+a} f(x) dx = \int_{-a}^0 f(x) dx + \int_0^{+a} f(x) dx.$$

Now, putting $x = -z$,

$$\begin{aligned} \int_{-a}^0 f(x) dx &= - \int_a^0 f(-z) dz = \int_0^a f(-z) dz \\ &= \int_0^a f(-x) dx. \end{aligned}$$

Hence, the result follows.

Cor. If $f(x)$ is an odd function of x i.e., $f(-x) = -f(x)$,

$$\int_{-a}^{+a} f(x) dx = 0,$$

and if $f(x)$ is an even function of x i.e., $f(-x) = f(x)$,

$$\int_{-a}^{+a} f(x) dx = 2 \int_0^a f(x) dx.$$

Illustration :

$$\int_{-\frac{\pi}{2}}^{+\frac{\pi}{2}} \sin^5 x dx = 0, \text{ and}$$

$$\int_{-\frac{\pi}{2}}^{+\frac{\pi}{2}} \sin^4 x dx = 2 \int_0^{\frac{1}{2}\pi} \sin^4 x dx.$$

6.9. Illustrative Examples.

By the help of the above properties of definite integrals we can evaluate many definite integrals without evaluating the corresponding indefinite integrals, as shown in the following examples.

Ex. 1. Show that $\int_0^{\frac{\pi}{2}} \log \tan x \, dx = 0$.

$$\begin{aligned} I &= \int_0^{\frac{\pi}{2}} \log \tan \left(\frac{\pi}{2} - x \right) dx \quad [\text{By (iv), Art. 6'8}] \\ &= \int_0^{\frac{\pi}{2}} \log \cot x \, dx = - \int_0^{\frac{\pi}{2}} \log \tan x \, dx = -I. \end{aligned}$$

$$\therefore 2I = 0; \quad \therefore I = 0.$$

Ex. 2. Show that $\int_0^{\frac{\pi}{2}} \frac{\sqrt{\sin x}}{\sqrt{\sin x} + \sqrt{\cos x}} \, dx = \frac{\pi}{4}$.

$$\begin{aligned} I &= \int_0^{\frac{\pi}{2}} \frac{\sqrt{\sin \left(\frac{\pi}{2} - x \right)}}{\sqrt{\sin \left(\frac{\pi}{2} - x \right)} + \sqrt{\cos \left(\frac{\pi}{2} - x \right)}} \, dx \\ &= \int_0^{\frac{\pi}{2}} \frac{\sqrt{\cos x}}{\sqrt{\cos x} + \sqrt{\sin x}} \, dx. \end{aligned}$$

$$\begin{aligned} \therefore 2I &= \int_0^{\frac{\pi}{2}} \frac{\sqrt{\sin x}}{\sqrt{\sin x} + \sqrt{\cos x}} \, dx + \int_0^{\frac{\pi}{2}} \frac{\sqrt{\cos x}}{\sqrt{\cos x} + \sqrt{\sin x}} \, dx \\ &= \int_0^{\frac{\pi}{2}} \frac{\sqrt{\sin x} + \sqrt{\cos x}}{\sqrt{\sin x} + \sqrt{\cos x}} \, dx = \int_0^{\frac{\pi}{2}} dx = \left[x \right]_0^{\frac{\pi}{2}} = \frac{1}{2}\pi. \end{aligned}$$

$$\therefore I = \frac{1}{4}\pi.$$

Ex. 3. Show that $\int_0^{\frac{\pi}{2}} \log \sin x \, dx = \int_0^{\frac{\pi}{2}} \log \cos x \, dx = \frac{\pi}{2} \log \frac{1}{2}$.

$$\begin{aligned} \int_0^{\frac{\pi}{2}} \log \sin x \, dx &= \int_0^{\frac{\pi}{2}} \log \sin \left(\frac{\pi}{2} - x \right) dx \\ &= \int_0^{\frac{\pi}{2}} \log \cos x \, dx. \end{aligned}$$

[By Art. 6'8, (iv)]

$$\begin{aligned}
2I &= \int_0^{\frac{\pi}{2}} \log \sin x \, dx + \int_0^{\frac{\pi}{2}} \log \cos x \, dx \\
&= \int_0^{\frac{\pi}{2}} (\log \sin x + \log \cos x) \, dx = \int_0^{\frac{\pi}{2}} \log (\sin x \cos x) \, dx \\
&= \int_0^{\frac{\pi}{2}} \log \left(\frac{\sin 2x}{2} \right) \, dx = \int_0^{\frac{\pi}{2}} (\log \sin 2x - \log 2) \, dx \\
&= \int_0^{\frac{\pi}{2}} \log \sin 2x \, dx - \frac{\pi}{2} \log 2.
\end{aligned}$$

Put $2x = z$; $\therefore dx = \frac{1}{2} dz$.

$$\begin{aligned}
\therefore \int_0^{\frac{\pi}{2}} \log \sin 2x \, dx &= \frac{1}{2} \int_0^{\pi} \log \sin z \, dz \\
&= \frac{1}{2} \int_0^{\pi} \log \sin x \, dx = I \quad [\text{By (vi), Art. 6.8}]
\end{aligned}$$

$$\therefore 2I = I - \frac{\pi}{2} \log 2; \quad \therefore I = -\frac{\pi}{2} \log 2 = \frac{\pi}{2} \log \frac{1}{2}.$$

Ex. 4. Show that $\int_0^1 \frac{\log(1+x)}{1+x^2} \, dx = \frac{\pi}{8} \log 2$.

Put $x = \tan \theta$; $\therefore dx = \sec^2 \theta \, d\theta$; also when $x = 0$, $\theta = 0$;
and when $x = 1$, $\theta = \frac{1}{4}\pi$.

$$\therefore I = \int_0^{\frac{1}{4}\pi} \log(1 + \tan \theta) \, d\theta = \int_0^{\frac{1}{4}\pi} \log \{1 + \tan(\frac{1}{4}\pi - \theta)\} \, d\theta.$$

[By Art. 6.8, (iv)]

$$\text{Now, } 1 + \tan\left(\frac{\pi}{4} - \theta\right) = 1 + \frac{1 - \tan \theta}{1 + \tan \theta} = \frac{2}{1 + \tan \theta};$$

$$\begin{aligned}
\therefore I &= \int_0^{\frac{1}{4}\pi} \log \frac{2}{1 + \tan \theta} \, d\theta = \int_0^{\frac{1}{4}\pi} \{\log 2 - \log(1 + \tan \theta)\} \, d\theta \\
&= \int_0^{\frac{1}{4}\pi} \log 2 \, d\theta - \int_0^{\frac{1}{4}\pi} \log(1 + \tan \theta) \, d\theta = \frac{1}{4}\pi \cdot \log 2 - I.
\end{aligned}$$

$$\therefore 2I = \frac{1}{4}\pi \cdot \log 2; \quad \therefore I = \frac{\pi}{8} \log 2.$$

Ex. 5. Show that $\int_{-a}^{+a} \frac{xe^{x^2}}{1+x^2} dx = 0$.

$$I = \int_{-a}^0 \frac{xe^{x^2}}{1+x^2} dx + \int_0^a \frac{xe^{x^2}}{1+x^2} dx = I_1 + I_2, \text{ say.}$$

Putting $x = -z$, in the first integral,

$$I_1 = \int_a^0 \frac{ze^{z^2}}{1+z^2} dz = - \int_0^a \frac{ze^{z^2}}{1+z^2} dz = - \int_0^a \frac{xe^{x^2}}{1+x^2} dx = -I_2.$$

Hence the result.

6.10. Two Important Definite Integrals.

A. If n be a positive integer,*

$$\begin{aligned} \int_0^{\frac{1}{2}\pi} \sin^n x \, dx &= \int_0^{\frac{1}{2}\pi} \cos^n x \, dx \\ &= \frac{n-1}{n} \cdot \frac{n-3}{n-2} \cdot \frac{n-5}{n-4} \dots \frac{3}{4} \cdot \frac{1}{2} \cdot \frac{\pi}{2} \\ \text{or} \quad &= \frac{n-1}{n} \cdot \frac{n-3}{n-2} \cdot \frac{n-5}{n-4} \dots \frac{4}{5} \cdot \frac{2}{3} \cdot 1 \end{aligned}$$

according as n is even or odd.

Proof. $\int \sin^n x \, dx = \int \sin^{n-1} x \cdot \sin x \, dx$
 $= \sin^{n-1} x \cdot (-\cos x) + (n-1) \int \sin^{n-2} x \cos^2 x \, dx$
(integrating by parts)

$$\begin{aligned} &= -\sin^{n-1} x \cos x + (n-1) \int \sin^{n-2} x (1 - \sin^2 x) \, dx \\ &= -\sin^{n-1} x \cos x + (n-1) \int \sin^{n-2} x \, dx - (n-1) \int \sin^n x \, dx. \end{aligned}$$

\therefore transposing $-(n-1) \int \sin^n x \, dx$ to the left side and dividing by n , we have

$$\int \sin^n x \, dx = -\frac{\sin^{n-1} x \cos x}{n} + \frac{(n-1)}{n} \int \sin^{n-2} x \, dx. \dots (1)$$

* For other forms of these integrals see § 8.3.

$$\begin{aligned} \therefore \int_0^{\frac{1}{2}\pi} \sin^n x \, dx &= \left[-\frac{\sin^{n-1} x \cos x}{n} \right]_0^{\frac{1}{2}\pi} + \frac{n-1}{n} \int_0^{\frac{1}{2}\pi} \sin^{n-2} x \, dx \\ &= \frac{n-1}{n} \int_0^{\frac{1}{2}\pi} \sin^{n-2} x \, dx. \end{aligned}$$

Hence, denoting $\int_0^{\frac{1}{2}\pi} \sin^n x \, dx$ by I_n , we have

$$I_n = \frac{n-1}{n} I_{n-2}. \quad \dots \quad \dots \quad \dots \quad (2)$$

Changing n into $n-2$, $n-4$, etc. successively, we have from (2),

$$I_{n-2} = \frac{n-3}{n-2} I_{n-4}; \quad I_{n-4} = \frac{n-5}{n-4} I_{n-6}, \text{ etc.}$$

$$\therefore I_n = \frac{n-1}{n} \cdot \frac{n-3}{n-2} \cdot \frac{n-5}{n-4} \dots \frac{3}{4} \cdot \frac{1}{2} I_0$$

$$\text{or,} \quad = \frac{n-1}{n} \cdot \frac{n-3}{n-2} \cdot \frac{n-5}{n-4} \dots \frac{4}{5} \cdot \frac{2}{3} I_1$$

according as n is even or odd.

$$\text{But } I_0 = \int_0^{\frac{1}{2}\pi} dx = \frac{1}{2}\pi$$

$$\text{and } I_1 = \int_0^{\frac{1}{2}\pi} \sin x \, dx = \left[-\cos x \right]_0^{\frac{1}{2}\pi} = 1.$$

Thus, we get the required value of $\int_0^{\frac{1}{2}\pi} \sin^n x \, dx$.

Exactly in the same way it can be shown that $\int_0^{\frac{1}{2}\pi} \cos^n x \, dx$ has precisely the same value as the above integral in either case, n being even or odd.

Otherwise, it can be shown thus :

$$\int_0^{\frac{1}{2}\pi} \cos^n x \, dx = \int_0^{\frac{1}{2}\pi} \cos^n (\frac{1}{2}\pi - x) \, dx = \int_0^{\frac{1}{2}\pi} \sin^n x \, dx.$$

Note. The student can easily detect the law of formation of the factors in the above formulæ, noting that when the index is even, an additional factor $\frac{1}{2}\pi$ is written at the end but when the index is odd, no factor involving π is introduced. The formulæ (1) and (2) above are called Reduction Formulæ. [See Chap. VIII.]

B. $\int_0^{\frac{1}{2}\pi} \sin^m x \cos^n x \, dx$, m, n being positive integers.*

$$\begin{aligned} \int \sin^m x \cos^n x \, dx &= \int \cos^{n-1} x \cdot (\sin^m x \cos x) \, dx \\ &= \cos^{n-1} x \cdot \frac{\sin^{m+1} x}{m+1} + \frac{n-1}{m+1} \int \cos^{n-2} x \sin x \sin^{m+1} x \, dx \\ &\left[\text{integrating by parts and noting } \int \sin^m x \cos x \, dx = \frac{\sin^{m+1} x}{m+1} \right] \\ &= \frac{\sin^{m+1} x \cos^{n-1} x}{m+1} + \frac{n-1}{m+1} \int \sin^m x (1 - \cos^2 x) \cos^{n-2} x \, dx \\ &= \frac{\sin^{m+1} x \cos^{n-1} x}{m+1} + \frac{n-1}{m+1} \int \sin^m x \cos^{n-2} x \, dx \\ &\quad - \frac{n-1}{m+1} \int \sin^m x \cos^n x \, dx. \end{aligned}$$

Hence, transposing and dividing by $\frac{m+n}{m+1}$, we have

$$\begin{aligned} \int \sin^m x \cos^n x \, dx \\ &= \frac{\sin^{m+1} x \cos^{n-1} x}{m+n} + \frac{n-1}{m+n} \int \sin^m x \cos^{n-2} x \, dx. \quad \dots (1) \end{aligned}$$

* See Chap. VIII, Art. 8'15.

$$\begin{aligned} \int_0^{\frac{1}{2}\pi} \sin^m x \cos^n x \, dx &= \left[\frac{\sin^{m+1} x \cos^{n-1} x}{m+n} \right]_0^{\frac{1}{2}\pi} \\ &\quad + \frac{n-1}{m+n} \int_0^{\frac{1}{2}\pi} \sin^m x \cos^{n-2} x \, dx \\ &= \frac{n-1}{m+n} \int_0^{\frac{1}{2}\pi} \sin^m x \cos^{n-2} x \, dx. \quad (2) \end{aligned}$$

Again, writing $\int \sin^m x \cos^n x \, dx = \int \sin^{m-1} x (\cos^n x \sin x) dx$ and integrating by parts and proceeding as above, we get

$$\begin{aligned} \int \sin^m x \cos^n x \, dx &= -\frac{\sin^{m-1} x \cos^{n+1} x}{m+n} \\ &\quad + \frac{m-1}{m+n} \int \sin^{m-2} x \cos^n x \, dx \end{aligned}$$

and hence taking it between the limits 0 and $\frac{1}{2}\pi$, we get

$$\int_0^{\frac{1}{2}\pi} \sin^m x \cos^n x \, dx = \frac{m-1}{m+n} \int_0^{\frac{1}{2}\pi} \sin^{m-2} x \cos^n x \, dx. \quad \dots \quad (3)$$

Thus, denoting $\int_0^{\frac{1}{2}\pi} \sin^m x \cos^n x \, dx$ by $I_{m, n}$, we have

from (2) and (3),

$$\left. \begin{aligned} I_{m, n} &= \frac{n-1}{m+n} I_{m, n-2} \\ &= \frac{m-1}{m+n} I_{m-2, n} \end{aligned} \right\} \dots \dots \dots (4)$$

Again, since, $\int_0^{\frac{1}{2}\pi} \sin^m x \cos^n x \, dx$

$$\begin{aligned} &= \int_0^{\frac{1}{2}\pi} \sin^m (\tfrac{1}{2}\pi - x) \cos^n (\tfrac{1}{2}\pi - x) \, dx \\ &= \int_0^{\frac{1}{2}\pi} \sin^n x \cos^m x \, dx, \end{aligned}$$

$$I_{m, n} = I_{n, m}. \quad \dots \quad \dots \quad \dots \quad (5)$$

By means of the formulæ (2) and (3), either index can be reduced by 2, and by repetitions of this process we can, since m and n are positive integers, make the original integral *viz.*, $I_{m, n}$ depend upon one in which the indices are 1 or 0. The result, therefore, finally involves one or other of the following integrals :

$$\int_0^{\frac{1}{2}\pi} \sin x \cos x \, dx = \frac{1}{2} ; \quad \int_0^{\frac{1}{2}\pi} dx = \frac{\pi}{2} ;$$

$$\int_0^{\frac{1}{2}\pi} \sin x \, dx = 1 ; \quad \int_0^{\frac{1}{2}\pi} \cos x \, dx = 1$$
(6)

Thus, finally we have,

$$\int_0^{\frac{1}{2}\pi} \sin^m x \cos^n x \, dx = \int_0^{\frac{1}{2}\pi} \cos^m x \sin^n x \, dx$$

$$= \frac{1.3.5\dots(m-1).1.3.5\dots(n-1)}{2.4.6\dots(m+n)} \cdot \frac{\pi}{2},$$

when both m and n are even integers ; and

$$= \frac{2.4.6\dots(m-1)}{(n+1)(n+3)\dots(n+m)},$$

when one of the two indices, say m , is an odd integer.

Note. The above definite integrals are of great use in the application of Integral Calculus to practical problems ; *e.g.*, in the determination of centre of gravity, in the calculation of area, etc. ; and also many elementary definite integrals on suitable substitution reduce to one or other of the above forms, as shown in the following examples.

6.11. Illustrative Examples.

Ex. 1. Evaluate $\int_0^1 x^6 \sqrt{1-x^2} \, dx$.

Put $x = \sin \theta$; $\therefore dx = \cos \theta \, d\theta$ and $1-x^2 = \cos^2 \theta$;

also when $x=0$, $\theta=0$, and when $x=1$, $\theta = \frac{1}{2}\pi$.

The given integral then reduces to

$$\int_0^{\frac{1}{2}\pi} \sin^6 \theta \cos^3 \theta \, d\theta = \frac{1.3.5.1}{2.4.6.8} \cdot \frac{\pi}{2} = \frac{5\pi}{256}.$$

Ex. 2. Evaluate $\int_0^1 x^2 (1-x)^{\frac{2}{3}} dx$.

Put $x = \sin^2 \theta$; $\therefore dx = 2 \sin \theta \cos \theta d\theta$

and when $x = 0, 1$, we have $\theta = 0, \frac{1}{2}\pi$ respectively.

$$\therefore I = 2 \int_0^{\frac{1}{2}\pi} \sin^5 \theta \cos^4 \theta d\theta = 2 \cdot \frac{2 \cdot 4}{5 \cdot 7 \cdot 9} = \frac{16}{315}$$

Ex. 3. Evaluate $\int_0^\pi \cos^n x dx$.

Since $\cos^n x = -\cos^n (\pi - x)$, when n is odd,

and $= \cos^n (\pi - x)$, when n is even,

\therefore by Art. 6.8 (vii), it follows that $I = 0$, when n is odd,

and $I = 2 \int_0^{\frac{1}{2}\pi} \cos^n x dx$, when n is even

$$= 2 \cdot \frac{n-1}{n} \cdot \frac{n-3}{n-2} \cdot \frac{n-5}{n-4} \dots \frac{3}{4} \cdot \frac{1}{2} \cdot \frac{\pi}{2} \quad [\text{By Art. 6.10(A)}]$$

EXAMPLES VI(B)

Show that :—

$$1. (i) \int_a^b f(a+b-x) dx = \int_a^b f(x) dx.$$

$$(ii) \int_{a-c}^{b-c} f(x+c) dx = \int_a^b f(x) dx.$$

$$(iii) \int_a^b f(nx) dx = \frac{1}{n} \int_{na}^{nb} f(x) dx.$$

$$2. \int_0^{\frac{1}{2}\pi} \frac{\sin x}{\sin x + \cos x} dx = \frac{\pi}{4}.$$

$$3. \int_0^{\frac{1}{2}\pi} \frac{\cos x - \sin x}{1 + \sin x \cos x} dx = 0.$$

4. $\int_0^{\frac{1}{2}\pi} (a \cos^2 x + b \sin^2 x) dx = \frac{1}{2}\pi (a + b).$
5. $\int_0^{\frac{1}{2}\pi} \sin 2x \log \tan x dx = 0.$
6. $\int_0^{\pi} x f(\sin x) dx = \frac{1}{2}\pi \int_0^{\pi} f(\sin x) dx.$
7. $\int_0^{\pi} x \log \sin x dx = \frac{1}{2}\pi^2 \log \frac{1}{2}.$
8. $\int_0^{\pi} x \sin x \cos^2 x dx = \frac{\pi}{3}.$
9. $\int_0^{\pi} x \sin^2 x dx = \frac{1}{2}\pi^2.$
10. $\int_0^{\pi} \frac{\sin 4x}{\sin x} dx = 0.$
11. $\int_{-a}^{+a} x \sqrt{a^2 - x^2} dx = 0.$
12. $\int_0^{2\pi} \sin^4 \frac{1}{2}x \cos^5 \frac{1}{2}x dx = 0.$
13. $\int_0^1 \log \sin (\frac{1}{2}\pi\theta) d\theta = \log \frac{1}{2}. \quad [\text{Put } \frac{1}{2}\pi\theta = x]$
14. $\int_0^1 \frac{\log x}{\sqrt{1-x^2}} dx = \frac{\pi}{2} \log \frac{1}{2}. \quad [\text{Put } x = \sin \theta]$
15. $\int_0^{\frac{1}{2}\pi} \log (1 + \tan \theta) d\theta = \frac{\pi}{8} \log 2.$
16. $\int_0^{\pi} x \cos^4 x dx = \frac{3}{16} \pi^2.$

$$17. (i) \int_0^{\frac{1}{2}\pi} \cos^6 x \, dx = \frac{5}{32} \pi.$$

$$(ii) \int_0^{\frac{1}{2}\pi} \sin^9 x \, dx = \frac{128}{315}.$$

$$(iii) \int_0^{\frac{1}{2}\pi} \sin^4 \theta \cos^8 \theta \, d\theta = \frac{7\pi}{2048}.$$

$$(iv) \int_0^{\frac{1}{2}\pi} \sin^4 x \cos^5 x \, dx = \frac{8}{315}.$$

$$(v) \int_0^{\pi} (1 - \cos x)^2 \, dx = \frac{5\pi}{2}.$$

$$(vi) \int_0^{\pi} \sin^3 x \cos^3 x \, dx = 0.$$

$$(vii) \int_0^{\pi} \cos^7 \theta \, d\theta = 0.$$

$$(viii) \int_{-\frac{\pi}{2}}^{+\frac{\pi}{2}} \sin^7 x \, dx = 0.$$

$$18. (i) \int_0^1 x^3 (1-x)^3 \, dx = \frac{1}{140}.$$

$$(ii) \int_0^1 x^3 (1-x^2)^{\frac{5}{2}} \, dx = \frac{2}{63}.$$

$$(iii) \int_0^a \frac{x^4}{\sqrt{a^2 - x^2}} \, dx = \frac{3\pi}{16} a^4.$$

$$(iv) \int_0^1 \frac{x^6 \, dx}{\sqrt{1-x^2}} = \frac{5}{32} \pi.$$

$$19. \int_0^1 \frac{dx}{(-2 - 2x + 2)^3} = \frac{3\pi + 8}{32}. \quad [\text{Put } x = 1 + \tan \theta]$$

$$20. (i) \int_0^{\pi} \frac{x \sin x}{1 + \cos^2 x} \, dx = \frac{\pi^2}{4}.$$

$$(ii) \int_0^{\frac{1}{2}\pi} \frac{\sin^2 x}{\sin x + \cos x} \, dx = \frac{1}{\sqrt{2}} \log (\sqrt{2} + 1).$$

$$(iii) \int_0^\pi \frac{x \tan x}{\sec x + \tan x} dx = \frac{1}{2}\pi (\pi - 2).$$

$$(iv) \int_0^\pi \frac{x dx}{1 + \cos^2 x} = \frac{\pi^2}{2\sqrt{2}} \quad [C. P. 1952]$$

$$(v) \int_0^{\frac{1}{2}\pi} \frac{x dx}{\sec x + \operatorname{cosec} x} = \frac{\pi}{4} \{1 + \log(\sqrt{2} - 1)\}.$$

$$(vi) \int_0^1 \cot^{-1}(1 - x + x^2) dx = \frac{1}{2}\pi - \log 2.$$

$$(vii) \int_0^\pi \frac{x dx}{a^2 \sin^2 x + b^2 \cos^2 x}, (a, b > 0) = \frac{\pi^2}{2ab}.$$

$$(viii) \int_0^{\frac{1}{2}\pi} \frac{x dx}{1 + \cos 2x + \sin 2x} = \frac{\pi}{16} \log 2.$$

$$(ix) \int_0^a \frac{a(x - \sqrt{a^2 - x^2})^2}{(2x^2 - a^2)^2} dx = \frac{1}{\sqrt{2}} \log(\sqrt{2} + 1).$$

$$(x) \int_0^\pi \frac{x dx}{(a^2 \cos^2 x + b^2 \sin^2 x)^2} = \frac{\pi(a^2 + b^2)}{4a^3 b^3}.$$

21. If $I_n = \int_0^{\frac{1}{2}\pi} \tan^n \theta d\theta$, show that $I_n = \frac{1}{n-1} - I_{n-2}$.

Hence, find the value of $\int_0^{\frac{1}{2}\pi} \tan^6 x dx$.

22. Show that, if m and n are positive and m is integral,

$$\begin{aligned} \int_0^1 x^{n-1} (1-x)^{m-1} dx &= \int_0^1 x^{m-1} (1-x)^{n-1} dx \\ &= \frac{1.2.3 \dots (m-1)}{n(n+1) \dots (n+m-1)}. \end{aligned}$$

ANSWERS

21. $\frac{1}{15} - \frac{1}{4}\pi$.



CHAPTER VII

INFINITE (OR IMPROPER) INTEGRALS AND INTEGRATION OF INFINITE SERIES

7.1. Infinite Integrals.

In discussing definite integrals we have hitherto supposed that the range of integration is finite and the integrand is continuous in the range. If in an integral, either the range is infinite, or the integrand has an infinite discontinuity in the range (*i.e.*, the integrand tends to infinity at some points of the range), the integral is usually called an *Infinite Integral*, and by some writers, an *Improper Integral*. Simple cases of infinite integrals occur in elementary problems ; for example, in the problem of finding the area between a plane curve and its asymptote. We give below the definitions of infinite integrals in different cases.

(A) Infinite range.

$$(i) \int_a^{\infty} f(x) dx \text{ is defined as } \lim_{\epsilon \rightarrow \infty} \int_a^{\epsilon} f(x) dx,$$

provided $f(x)$ is integrable in (a, ϵ) , and this limit exists.

$$(ii) \int_{-\infty}^b f(x) dx \text{ is defined as } \lim_{\epsilon \rightarrow -\infty} \int_{\epsilon}^b f(x) dx,$$

provided $f(x)$ is integrable in (ϵ, b) , and this limit exists.

(iii) If the infinite integrals $\int_{-\infty}^a f(x) dx$ and $\int_a^{\infty} f(x) dx$

both exist, we say that $\int_{-\infty}^{+\infty} f(x) dx$ exists, and

$$\int_{-\infty}^{+\infty} f(x) dx = \int_{-\infty}^a f(x) dx + \int_a^{\infty} f(x) dx.$$

Note. In the above cases, when the limit tends to a finite number, the integral is said to be **convergent**, when it tends to infinity with a fixed sign, it is said to be **divergent**, and when it does not tend to any fixed limit, finite, or infinite, it is said to be **oscillatory**. When an integral is divergent or oscillatory, some writers say that the *integral does not exist* or the *integral has no meaning*. [See Ex. 2, § 7·2.]

(B) Integrand infinitely discontinuous at a point.

(i) If $f(x)$ is infinitely discontinuous only at the end-point a , i.e., if $f(x) \rightarrow \infty$, as $x \rightarrow a$, then

$$\int_a^b f(x) dx \text{ is defined as } \lim_{\epsilon \rightarrow 0} \int_{a+\epsilon}^b f(x) dx, \epsilon > 0,$$

provided $f(x)$ be integrable in $(a + \epsilon, b)$, and this limit exists.

(ii) If $f(x)$ is infinitely discontinuous only at the end-point b , i.e., if $f(x) \rightarrow \infty$ as $x \rightarrow b$, then

$$\int_a^b f(x) dx \text{ is defined as } \lim_{\epsilon \rightarrow 0} \int_a^{b-\epsilon} f(x) dx, \epsilon > 0,$$

provided $f(x)$ is integrable in $(a, b - \epsilon)$, and this limit exists.

(iii) If $f(x)$ is infinitely discontinuous at an internal point c ($a < c < b$) i.e., if $f(x) \rightarrow \infty$ as $x \rightarrow c$, then

$$\int_a^b f(x) dx = \lim_{\epsilon \rightarrow 0} \int_a^{c-\epsilon} f(x) dx + \lim_{\epsilon' \rightarrow 0} \int_{c+\epsilon'}^b f(x) dx$$

when $\epsilon \rightarrow 0$ and $\epsilon' \rightarrow 0$ independently.

Note. It sometimes happens that no definite limit exists when ϵ and ϵ' tend to zero *independently*, but that a limit exists when $\epsilon = \epsilon'$. [See *Ex. 7, Art. 7.2*]. When $\epsilon = \epsilon'$, the value of the limit on the right side when it exists is called the *principal value* of the improper integral and is very often denoted by $P \int_a^b f(x) dx$.

(iv) If a and b are both points of infinite discontinuity, then $\int_a^b f(x) dx$ is defined as $\int_a^c f(x) dx + \int_c^b f(x) dx$ when these two integrals exist, as defined above, c being a point between a and b .

7.2. Illustrative Examples.

Ex. 1. Evaluate $\int_0^{\infty} e^{-x} dx$.

$$I = \lim_{\epsilon \rightarrow \infty} \int_0^{\epsilon} e^{-x} dx = \lim_{\epsilon \rightarrow \infty} (1 - e^{-\epsilon}) = 1.$$

Ex. 2. Evaluate $\int_0^{\infty} \cos tx dx$.

$$I = \lim_{\epsilon \rightarrow \infty} \int_0^{\epsilon} \cos tx dx = \lim_{\epsilon \rightarrow \infty} \frac{\sin t\epsilon}{t}; \text{ but this limit does not exist.}$$

Hence, *the integral does not exist.**

*Although this integral does not exist in the manner defined above, it is expressed in terms of Dirac's delta function [$\delta(t)$] in modern mathematics. Detailed discussion is outside the scope of this book.

Ex. 3. Evaluate $\int_{-\infty}^{+\infty} \frac{dx}{1+x^2}$.

$$I = \int_{-\infty}^a \frac{dx}{1+x^2} + \int_a^{\infty} \frac{dx}{1+x^2}$$

$$\int_{-\infty}^a \frac{dx}{1+x^2} = \lim_{\epsilon \rightarrow -\infty} \int_{\epsilon}^a \frac{dx}{1+x^2} = \lim_{\epsilon \rightarrow -\infty} (\tan^{-1}a - \tan^{-1}\epsilon) \\ = \tan^{-1}a + \frac{1}{2}\pi.$$

$$\int_a^{\infty} \frac{dx}{1+x^2} = \lim_{\epsilon' \rightarrow \infty} \int_a^{\epsilon'} \frac{dx}{1+x^2} = \lim_{\epsilon' \rightarrow \infty} (\tan^{-1}\epsilon' - \tan^{-1}a) \\ = \frac{1}{2}\pi - \tan^{-1}a;$$

$$\therefore I = (\tan^{-1}a + \frac{1}{2}\pi) + (\frac{1}{2}\pi - \tan^{-1}a) = \pi.$$

Ex. 4. Evaluate $\int_0^1 \frac{dx}{x^{\frac{3}{2}}}$.

Here, $\frac{1}{x^{\frac{3}{2}}}$ tends to ∞ as x tends to $+0$.

$$\therefore \int_0^1 \frac{dx}{x^{\frac{3}{2}}} = \lim_{\epsilon \rightarrow 0} \int_{\epsilon}^1 \frac{dx}{x^{\frac{3}{2}}} = \lim_{\epsilon \rightarrow 0} 3(1 - \epsilon^{\frac{1}{2}}) = 3.$$

Ex. 5. Evaluate $\int_{-1}^{+1} \frac{dx}{x^2}$.

Here, $\frac{1}{x^2} \rightarrow \infty$ as $x \rightarrow 0$, an interior point of the interval $(-1, 1)$.

$$\therefore I = \int_{-1}^0 \frac{dx}{x^2} + \int_0^1 \frac{dx}{x^2}.$$

$$\text{Now, } \int_0^1 \frac{dx}{x^2} = \lim_{\epsilon \rightarrow 0} \int_{\epsilon}^1 \frac{dx}{x^2} = \lim_{\epsilon \rightarrow 0} \left(\frac{1}{\epsilon} - 1 \right);$$

this limit does not exist. So $\int_0^1 \frac{dx}{x^2}$ does not exist.

Similarly, $\int_{-1}^0 \frac{dx}{x^2}$ does not exist.

$$\therefore \int_{-1}^{+1} \frac{dx}{x^2} \text{ has no meaning.}$$

Note. In examples of this type usually a mistake is committed in this way :

$$\text{Since } \int \frac{1}{x^2} dx = -\frac{1}{x}, \quad \therefore \int_{-1}^{+1} \frac{1}{x^2} dx = \left[-\frac{1}{x} \right]_{-1}^{+1} = -2,$$

which is wrong.

In this connection, it should be carefully noted that the relation $\int_a^b f(x) dx = F(b) - F(a)$ cannot be used without special examination unless $F'(x) = f(x)$ for *all* values of x from a to b , both inclusive.

Here, since the relation $\frac{d}{dx} \left(-\frac{1}{x} \right) = \frac{1}{x^2}$ fails to have any meaning when $x=0$, and 0 is a value between -1 and $+1$, we cannot directly apply the Fundamental theorem of Integral Calculus to evaluate this definite Integral.

Ex. 6. Show that $\int_0^{\infty} e^{-ax} \cos bx dx = \frac{a}{a^2 + b^2}$, $a > 0$.

$$\begin{aligned} \int_0^{\epsilon} e^{-ax} \cos bx dx &= \left[\frac{e^{-ax} (-a \cos bx + b \sin bx)}{a^2 + b^2} \right]_0^{\epsilon} \quad [\text{Art. 3.3}] \\ &= \frac{1}{a^2 + b^2} \{ e^{-a\epsilon} (-a \cos b\epsilon + b \sin b\epsilon) - (-a) \}. \end{aligned}$$

$$\begin{aligned} \therefore \int_0^{\infty} e^{-ax} \cos bx dx &= \lim_{\epsilon \rightarrow \infty} \int_0^{\epsilon} e^{-ax} \cos bx dx \\ &= \lim_{\epsilon \rightarrow \infty} \left[\frac{1}{a^2 + b^2} \{ e^{-a\epsilon} (-a \cos b\epsilon + b \sin b\epsilon) + a \} \right]. \end{aligned}$$

$$\text{Now, } \lim_{\epsilon \rightarrow \infty} e^{-a\epsilon} (-a \cos b\epsilon + b \sin b\epsilon) = 0$$

[$\because e^{-a\epsilon} \rightarrow 0$ and $\cos b\epsilon$ and $\sin b\epsilon$ are bounded]

$$\therefore \int_0^{\infty} e^{-ax} \cos bx dx = \frac{a}{a^2 + b^2}.$$

Ex. 7. Evaluate $\int_{-1}^{+1} \frac{dx}{x}$.

The integrand here is undefined for $x=0$.

$$\begin{aligned} \therefore \int_{-1}^{+1} \frac{1}{x} dx &= \lim_{\epsilon \rightarrow 0} \int_{+1}^{-\epsilon} \frac{dx}{x} + \lim_{\epsilon' \rightarrow 0} \int_{\epsilon'}^1 \frac{dx}{x} \\ &= \lim_{\epsilon \rightarrow 0} \left[\log(-x) \right]_{-1}^{-\epsilon} + \lim_{\epsilon' \rightarrow 0} \left[\log x \right]_{\epsilon'}^1 \\ &= \lim_{\epsilon \rightarrow 0} \log \epsilon - \lim_{\epsilon' \rightarrow 0} \log \epsilon' = \lim_{\epsilon, \epsilon'} \log \frac{\epsilon}{\epsilon'} \end{aligned}$$

as ϵ and ϵ' tend to zero independently.

But this limit is not definite, since it depends upon the ratio $\epsilon : \epsilon'$, which may be anything, since ϵ and ϵ' are both arbitrary positive numbers.

But if we put $\epsilon = \epsilon'$, we get $P \int_{-1}^{+1} \frac{dx}{x} = Lt_{\epsilon \rightarrow 0} \log 1 = 0$.

Thus although the general value of the integral does not exist, its principal value exists.

Note. $\int_{-1}^{-\epsilon} \frac{dx}{x}$, where the range of integration is such that x is negative throughout, may be written, by putting $z = -x$, as $\int_1^{\epsilon} \frac{dz}{z} = \left[\log z \right]_1^{\epsilon} = \left[\log (-x) \right]_{-1}^{-\epsilon}$, for $\log x$ is imaginary here.

Ex. 8. Evaluate $\int_0^{\infty} \frac{x^2}{(1+x^2)^2} dx$.

Put $x = \tan \theta$; $\therefore dx = \sec^2 \theta d\theta$; as x increases from 0 to ∞ , θ increases from 0 to $\frac{1}{2}\pi$.

$$\therefore I = \int_0^{\frac{1}{2}\pi} \frac{\tan^2 \theta \sec^2 \theta}{\sec^4 \theta} d\theta = \int_0^{\frac{1}{2}\pi} \sin^2 \theta d\theta = \frac{1}{4}\pi.$$

Note. Thus sometimes an infinite integral can be transformed into an ordinary definite integral by a suitable substitution. But whenever a substitution is used to evaluate an infinite integral, we must see that the transformation is legitimate.

Ex. 9. Show that $\int_0^{\infty} e^{-x} x^n dx = n!$, n being a positive integer.

[C. P. 1938]

Let I_n denote the given integral.

$$I_n = Lt_{\epsilon \rightarrow \infty} \int_0^{\epsilon} e^{-x} x^n dx$$

$$= Lt_{\epsilon \rightarrow \infty} \left\{ \left[-e^{-x} x^n \right]_0^{\epsilon} + n \int_0^{\epsilon} e^{-x} x^{n-1} dx \right\}$$

[integrating by parts]

$$= n Lt_{\epsilon \rightarrow \infty} \int_0^{\epsilon} e^{-x} x^{n-1} dx, \quad \because Lt_{\epsilon \rightarrow \infty} e^{-\epsilon} \epsilon^n = 0,$$

[See Das & Mukherjees' Differential Calculus, Chap. on Indeterminate Forms, sum no. 2(iii).]

$$= n I_{n-1} = n(n-1) I_{n-2} \text{ (as before)}$$

$$= n(n-1)(n-2) I_{n-3} = \text{etc.}$$

$$= n(n-1)(n-2) \dots 2.1 \int_0^{\infty} e^{-x} dx$$

$$= n!, \text{ since } \int_0^{\infty} e^{-x} dx = 1. \text{ [See Ex. 1 above]}$$

7.3. The integral $\int_0^{\infty} e^{-x^2} dx$.

Since, $e^{-x^2} = 1/e^{x^2}$ is positive and $< \frac{1}{1+x^2}$, (for $x > 0$)

it follows that $\int_0^X e^{-x^2} dx$ increases monotonically with X ,

and $\int_0^X e^{-x^2} dx < \int_0^X \frac{dx}{1+x^2}$ i.e., $< \tan^{-1} X$.

[See Appendix A, §4]

This being true for all positive values of X , however large, and as $\tan^{-1} X$ increases with X and $\rightarrow \frac{1}{2}\pi$ as $X \rightarrow \infty$, it follows that $\int_0^X e^{-x^2} dx$ monotonically increases with X , and is bounded above.

Thus, the infinite integral $\int_0^{\infty} e^{-x^2} dx$ is *convergent*.

Denote it by I .

Now, a being any positive number, replace x by ax .

Then, $I = \int_0^{\infty} ae^{-a^2x^2} dx$.

$\therefore I.e^{-a^2} = \int_0^{\infty} ae^{-a^2(1+x^2)} dx$.

Since $ae^{-a^2(1+x^2)}$ is a continuous function for all positive values of x and a (which are independent), assuming the validity of integration under an integral sign in this case,

$$I \int_0^{\infty} e^{-a^2} da = \int_0^{\infty} \left\{ \int_0^{\infty} ae^{-a^2(1+x^2)} da \right\} dx. \quad \dots (i)$$

Also for any particular value of x , $\int_0^\epsilon a e^{-a^2(1+x^2)} da$

$$= \left[-\frac{1}{2} \cdot \frac{1}{1+x^2} \cdot e^{-a^2(1+x^2)} \right]_0^\epsilon = \frac{1}{2(1+x^2)} \left[1 - e^{-\epsilon^2(1+x^2)} \right]$$

$\rightarrow \frac{1}{2(1+x^2)}$ as $\epsilon \rightarrow \infty$.

Hence from (i), $I^2 = \int_0^\infty \frac{1}{2} \cdot \frac{1}{1+x^2} dx$

$$\frac{1}{2} \cdot \frac{\pi}{2}, \text{ or, } I = \frac{1}{2} \sqrt{\pi},$$

i.e., $\int_0^\infty e^{-x^2} dx = \frac{1}{2} \sqrt{\pi}$.

7.4. The integral $\int_0^\infty \frac{\sin bx}{x} dx$.

Let $u = \int_0^\infty \frac{e^{-ax} \sin bx}{x} dx, a > 0$.

Assuming the validity of differentiation under the integral sign, we have

$$\frac{du}{db} = \int_0^\infty e^{-ax} \cos bx dx$$

$$= \frac{a}{a^2 + b^2}, a > 0. \quad [\text{Sec Ex. 6, Art. 7.2}]$$

Now, integrating with respect to b ,

$$u = a \int \frac{db}{a^2 + b^2} = a \cdot \frac{1}{a} \tan^{-1} \frac{b}{a} + C = \tan^{-1} \frac{b}{a} + C \dots (1)$$

where C is the constant of integration.

From the given integral, we see that when $b = 0, u = 0$.

\therefore from (1), we deduce $C = 0$.

$$\therefore \int_0^\infty \frac{e^{-ax} \sin bx}{x} dx = \tan^{-1} \frac{b}{a} \dots (2)$$

* For an alternative proof see Chapter VIII, Art. 8.21.

Assuming u a continuous function of a , we deduce from (2) when $a \rightarrow 0$,

$$\int_0^{\infty} \frac{\sin bx}{x} dx = \frac{\pi}{2} \quad \text{or} \quad -\frac{\pi}{2}. \quad \dots (3)$$

according as $b >$ or $<$ 0.

Cor. When $b=1$, we have

$$\int_0^{\infty} \frac{\sin x}{x} dx = \frac{\pi}{2}. \quad \dots \quad \dots (4)$$

Note. There are other methods of obtaining the result. Students may consult text-books on Mathematical Analysis.

7.5. Integration of Infinite Series.

We have proved in Art. 1.4 that the integral of the sum of a finite number of terms is equal to the sum of the integrals of these terms. Now, the question arises whether this principle can be extended to the case, when the number of terms is *not finite*. In other words, is it always permissible to integrate an infinite series term by term? It is beyond the scope of an elementary treatise like this to investigate the conditions under which an infinite series can properly be integrated term by term. We should merely state the theorem that applies to most of the series that are ordinarily met with in elementary mathematics. For a fuller discussion students may consult any text-book on Mathematical Analysis.

Theorem. *A power series can be integrated term by term throughout any interval contained in the interval of convergence, but not necessarily extending to the end-points of the interval.*

Thus, if $f(x)$ can be expanded in a convergent infinite power series for all values of x in a certain continuous range, viz.,

$$f(x) = a_0 + a_1x + a_2x^2 + \dots \text{ to } \infty,$$

$$\begin{aligned} \text{then } \int_a^b f(x) dx &= \int_a^b (a_0 + a_1x + a_2x^2 + \dots) dx \\ &= \Sigma \int_a^b a_r x^r dx, \end{aligned}$$

$$\begin{aligned} \text{or, } \int_a^x f(x) dx &= \int_a^x (a_0 + a_1x + a_2x^2 + \dots) dx \\ &= \Sigma \int_a^x a_r x^r dx, \end{aligned}$$

provided the intervals (a, b) and (a, x) lie within the interval of convergence of the power series.

Ex. Find by integration the series for $\tan^{-1}x$.

$$\frac{1}{1+x^2} = 1 - x^2 + x^4 - x^6 + \dots \text{ to } \infty, \text{ if } x^2 < 1.$$

\therefore integrating both sides between the limits 0 and x ,

$$\int_0^x \frac{dx}{1+x^2} = \int_0^x (1 - x^2 + x^4 - x^6 + \dots) dx.$$

$\therefore \tan^{-1}x = x - \frac{1}{3}x^3 + \frac{1}{5}x^5 - \frac{1}{7}x^7 + \dots, -1 < x < 1.$

EXAMPLES VII

Evaluate when possible, the following integrals :—

1. (i) $\int_0^{\infty} \frac{dx}{1+x^2}.$

(ii) $\int_0^{\infty} \frac{x dx}{x^2+4}.$

2. (i) $\int_0^{\infty} \frac{dx}{x^2-1}.$

(ii) $\int_0^{\infty} x e^{-x^2} dx.$

3. (i) $\int_{-1}^{+1} \frac{dx}{x^3}.$

(ii) $\int_{-\infty}^{+\infty} \frac{dx}{x^3}.$

$$4. \text{ (i) } \int_0^{\pi} \frac{\sin x \, dx}{\cos^2 x}. \quad \text{(ii) } \int_0^{\pi} \frac{dx}{1 + \cos x}.$$

$$5. \text{ (i) } \int_0^{\infty} \frac{dx}{x(1+x)}. \quad \text{(ii) } \int_0^2 \frac{dx}{2-x}.$$

$$6. \text{ (i) } \int_{-1}^{+1} \sqrt{\frac{1+x}{1-x}} \, dx. \quad \text{(ii) } \int_0^{\infty} \frac{dx}{(1+x^2)^2}.$$

$$7. \text{ (i) } \int_0^{\infty} \frac{x \, dx}{(1+x^2)^2}. \quad \text{(ii) } \int_{-\infty}^{+\infty} \frac{x \, dx}{x^2+1}.$$

$$8. \text{ (i) } \int_0^2 \frac{dx}{(1-x)^2}. \quad \text{(ii) } \int_0^{\infty} \frac{dx}{(x+1)(x+2)}.$$

Show that :—

$$9. \int_0^{\infty} \frac{dx}{(x^2+a^2)(x^2+b^2)} = \frac{\pi}{2ab(a+b)}. \quad [a, b > 0]$$

$$10. \int_0^{\infty} \frac{x \, dx}{(x^2+a^2)(x^2+b^2)} = \frac{1}{a^2-b^2} \log \frac{a}{b}. \quad [a, b > 0]$$

$$11. \int_0^{\infty} \frac{x^2 \, dx}{(x^2+a^2)(x^2+b^2)} = \frac{\pi}{2(a+b)}. \quad [a, b > 0]$$

$$12. \text{ (i) } \int_0^{\infty} e^{-x} (\cos x - \sin x) \, dx = 0. \quad \text{(ii) } \int_0^{\infty} \frac{\log x}{1+x^2} \, dx = 0.$$

[(ii) Divide the range $(0, \infty)$ into two parts $(0, 1)$ and $(1, \infty)$]

$$13. \int_{-\infty}^{+\infty} \frac{dx}{x^2+2x+2} = \pi.$$

$$\therefore \int_0^1 x^n \log x \, dx = -\frac{1}{(n+1)^2} \quad (n > -1).$$

$$\therefore \int_0^{\infty} e^{-ax} \sin bx \, dx = \frac{b}{a^2+b^2} \quad (a > 0). \quad [C. P. 1938]$$

$$16. (i) \int_0^{\infty} \frac{dx}{x^2 + 2x \cos \theta + 1} = 2 \int_0^1 \frac{dx}{x^2 + 2x \cos \theta + 1}.$$

$$(ii) \int_0^{\infty} \frac{dx}{\{x + \sqrt{1+x^2}\}^n} = \frac{n}{n^2 - 1}$$

where n is an integer greater than one.

$$(iii) \int_0^{\infty} \frac{x dx}{(1+x)(1+x^2)} = \frac{\pi}{4}.$$

$$17. (i) \int_0^{\infty} \frac{\sin ax \cos bx}{x} dx = \frac{1}{2}\pi, 0, \text{ or } \frac{1}{4}\pi$$

according as $a >$, $<$ or $=b$, (a and b being supposed positive).

$$(ii) \int_0^{\infty} \frac{(\sin 2x + \cos 2x)^2 - (\sin x + \cos x)^2}{x} dx = 0.$$

$$18. \int_0^{\infty} \frac{\sin^3 x}{x} dx = \frac{\pi}{4}.$$

$$19. \int_0^{\infty} \frac{\sin^5 x}{x} dx = \frac{3}{16} \pi.$$

$$20. \int_0^{\infty} \frac{\sin^2 mx}{x^2} dx = \frac{\pi}{2} m \text{ or, } -\frac{\pi}{2} m$$

according as $m >$ or < 0 .

$$21. \int_0^{\infty} \left(\frac{\sin x}{x}\right)^2 dx = \frac{\pi}{2}$$

$$22. \int_0^{\infty} \left(\frac{\sin x}{x}\right)^3 dx = \frac{3\pi}{8}.$$

23. Find by integration the power series for the following :—

$$(i) \log(1+x).$$

$$(ii) \log(1-x).$$

$$(iii) \sin^{-1}x.$$

24. Show that :—

$$(i) \int \frac{dx}{\sqrt{\sin x}} = 2 \sqrt{\sin x} \left[1 + \frac{1}{2} \frac{\sin^2 x}{5} + \frac{1.3}{2.4} \frac{\sin^4 x}{9} + \dots \right].$$

$$(ii) \int \frac{dx}{\sqrt{1+x^4}} = \frac{x}{1} - \frac{1}{2} \frac{x^5}{5} + \frac{1.3}{2.4} \frac{x^9}{9} - \dots; [x^2 < 1].$$

$$(iii) \int_0^x \frac{\sin x}{x} dx = x - \frac{x^3}{3.3!} + \frac{x^5}{5.5!} - \dots$$

$$(iv) \int_a^b \frac{e^x}{x} dx = \log \frac{b}{a} + (b-a) + \frac{b^2 - a^2}{2.2!} + \frac{b^3 - a^3}{3.3!} + \dots$$

$$(v) \int_0^{\frac{1}{2}\pi} \sqrt{1 - e^2 \sin^2 \phi} d\phi, \text{ where } e^2 < 1,$$

$$= \frac{\pi}{2} \left\{ 1 - \left(\frac{1}{2} \right)^2 \frac{e^2}{1} - \left(\frac{1.3}{2.4} \right)^2 \frac{e^4}{3} - \dots \right\}.$$

$$(vi) \int_0^{\frac{1}{2}\pi} \frac{dx}{\sqrt{1 - k^2 \sin^2 x}}, \text{ where } k^2 < 1,$$

$$= \frac{\pi}{2} \left\{ 1 + \left(\frac{1}{2} \right)^2 k^2 + \left(\frac{1.3}{2.4} \right)^2 k^4 + \dots \right\}.$$

$$(vii) \int_0^1 \frac{dx}{1+x^2} = 1 - \frac{1}{3} + \frac{1}{5} - \dots$$

$$(viii) \int_0^{\frac{1}{2}} \frac{dx}{\sqrt{1-x^2}} = \frac{1}{2} + \frac{1}{2.3.2^3} + \frac{1.3}{2.4.5.2^5} + \dots$$

$$25. \int_0^1 \frac{\tan^{-1} x}{x} dx = \sum_0^{\infty} (-1)^n \frac{1}{(2n+1)^2}.$$

$$26. (i) \int_0^1 \frac{\log x}{1+x} dx = -\frac{\pi^2}{12} \quad \left[\text{Use } \sum \frac{1}{n^2} = \frac{\pi^2}{6} \right]$$

$$(ii) \int_0^1 \frac{\log(1-x)}{x} dx = -\frac{\pi^2}{6}.$$

27. (i) Show that if $a > 0$,

$$\int_0^1 \frac{x^{a-1}}{1+x} dx = \frac{1}{a} - \frac{1}{a+1} + \frac{1}{a+2} - \frac{1}{a+3} + \dots$$

Hence, deduce the value of the series

$$1 - \frac{1}{2} + \frac{1}{3} - \frac{1}{4} + \dots$$

(ii) Show that if $a > 0, b > 0$,

$$\int_0^1 \frac{x^{a-1}}{1+x^b} dx = \frac{1}{a} - \frac{1}{a+b} + \frac{1}{a+2b} - \frac{1}{a+3b} + \dots$$

28. Show that

$$\int_0^1 x^{2p-1} \log(1+x) dx = \frac{1}{2p} \left[\frac{1}{1.2} + \frac{1}{3.4} + \dots - (2p-1)2p \right]$$

[Integrate by parts]

ANSWERS

- | | | | |
|---|----------------------|---|-------------------------|
| 1. (i) $\frac{1}{2}\pi$. | (ii) does not exist. | 2. (i) $\frac{1}{2} \log 3$. | (ii) $\frac{1}{2}$. |
| 3. (i) principal value is 0. | | (ii) principal value is 0. | |
| 4. (i) does not exist. | | (ii) does not exist. | |
| 5. (i) $\log 2$. | (ii) does not exist. | 6. (i) π . | (ii) $\frac{5}{2}\pi$. |
| 7. (i) $\frac{1}{2}$. | (ii) 0. | 8. (i) does not exist. | (ii) $\log 2$. |
| 17. (i) $x - \frac{1}{2}x^2 + \frac{1}{3}x^3 - \dots$ | | (ii) $-[x + \frac{1}{2}x^2 + \frac{1}{3}x^3 + \dots]$. | |
| (iii) $x + \frac{1}{2} \cdot \frac{x^3}{3} + \frac{1.3}{2.4} \cdot \frac{x^5}{5} + \dots$ | | | |

CHAPTER VII(A)

IRRATIONAL FUNCTIONS

7(A)*1. In the previous chapters we have discussed simple cases of integrals of irrational functions. We shall now consider here some harder types of such integrals.

7(A)*2. If the integrand contains only fractional powers of x *i.e.*, if the integrand be of the form

$$F(x^{\frac{1}{n}}),$$

where $F(u)$ is a rational function of u ,

the *substitution* is $x = z^n$,

where n is the least common multiple of the denominators of the fractional exponents of x .

[See *Ex. 1 of Examples VII(A)*]

7(A)*3. If the integrand contains only fractional powers of $(a + bx)$ *i.e.*, if the integrand be of the form

$$F\{(a + bx)^{\frac{1}{n}}\},$$

where $F(u)$ is a rational function of u ,

the *substitution* is $a + bx = z^n$,

where n is the least common multiple of the denominators of the fractional exponents of $(a + bx)$.

[See *Ex. 2 and Ex. 3 of Examples VII(A)*]

7(A)4. If the integral be of the form

$$\int x^m(a+bx^n)^p dx,$$

where m, n, p are rational numbers.

(A) If p be a positive integer, expand $(a+bx^n)^p$ by the Binomial Theorem and integrate term by term.

[See *Ex. 4(i) of Examples VII(A)*]

(B) If p be a fraction, say, equal to r/s , where r and s are integers and s is positive.

Case I. If $\frac{m+1}{n}$ = an integer or zero,

the substitution is $a+bx^n = z^s$.

If $\frac{m+1}{n} \neq$ an integer or zero, we apply the following case II.

Case II. If $\frac{m+1}{n} + \frac{r}{s}$ = an integer or zero,

the general substitution is $a+bx^n = z^s x^n$ (1)

If however the integer is positive or zero,

alternative substitution is $a+bx^n = z^s$.

If the integer is negative,

the alternative substitution in the form $ax^{-n} + b$, which is practically the same as (1) of case II sometimes facilitates calculation.

[See *Ex. 1 of Art. 7(A)8*]

7(A)5. The integral of the form

$$\int \frac{dx}{(ax^2 + b)\sqrt{cx^2 + d}}$$

Here the *substitution* is

$$cx^2 + d = x^2 z^2.$$

Sometimes *trigonometrical substitutions* like

$x = k \tan \theta$, $x = k \sin \theta$, $x = k \sec \theta$, etc. facilitate integration.

[See *Ex. 28(ii)* of *Examples II(A)* and *Ex. 8(i)* and *Ex. 8(ii)* of *Examples VII(A)*]

7(A)*6. The integral of the form

$$\int \frac{dx}{(px^2 + qx + r) \sqrt{(ax^2 + bx + c)}}$$

Here we shall consider two cases only.

Case I. If $px^2 + qx + r$ breaks up into two linear factors of the forms $(mx + n)$ and $(m'x + n')$, then we resolve

$\frac{1}{(mx + n)(m'x + n')}$ into two partial fractions and the integral then transforms into the sum (or difference) of two integral of the type (B) of Art. 2*8.

[See *Examples 13* of *Ex. VII(A)*]

Case II. If $px^2 + qx + r$ is a perfect square, say $(lx + m)^2$, then the *substitution* is $lx + m = 1/z$.

In some cases *trigonometrical substitutions* as in Art. 7(A)*5 are effective.

If $q = 0$, $b = 0$, the integral reduces to the form given in the Art. 7(A)*5.

In all these cases, the *general substitution* is

$$\sqrt{\frac{ax^2 + bx + c}{px^2 + qx + r}} = z.$$

Briefly, we have considered integrals of the type

$$\int \frac{dx}{P\sqrt{Q}}$$

where P and Q are both *linear* functions of x , and P *linear*,
 Q *quadratic* [See Art. 2'8(A) and 2'8(B)]

and P *quadratic*, Q *quadratic*.

[See Art. 7(A)'5 and 7(A)'6]

Also, we have considered integrals of the type

$$\int \frac{f(x)}{P\sqrt{Q}} dx,$$

where $f(x)$ is a *polynomial*, and P, Q being *linear* or
quadratic. [See Ex. 11 to Ex. 15 of Examples VII(A)]

7(A)'7. The integral of the form

$$\int \frac{f(x)}{\sqrt{(ax^4 + 2bx^3 + cx^2 + 2bx + a)}} dx,$$

where $f(x)$ is a rational function of x .

The denominator can be written as

$$x\sqrt{\left\{a\left(x^2 + \frac{1}{x^2}\right) + 2b\left(x + \frac{1}{x}\right) + c\right\}}$$

and hence the *substitution* is

$$x + \frac{1}{x} = z \quad \text{or,} \quad x - \frac{1}{x} = z$$

according as $f(x)$ is expressible in the form

$$\left(x - \frac{1}{x}\right)\phi\left(x + \frac{1}{x}\right) \quad \text{or,} \quad \left(x + \frac{1}{x}\right)\phi\left(x - \frac{1}{x}\right).$$

If $b=0$, the *substitution*

$$x^2 + \frac{1}{x^2} = z \quad \text{or,} \quad x^2 - \frac{1}{x^2} = z$$

is sometimes useful.

[See Ex. 19 of Examples VII(A)]

7(A)·8. Illustrative Examples.

Ex. 1. Integrate $\int \frac{dx}{x^3 \sqrt[3]{1+x^3}}$.

Comparing it with the form of Art. 7(A)·4, we find here

$$m = -3, n = 3, r = -1, s = 3.$$

Now, $\frac{m+1}{n} \neq$ an integer, but

$$\frac{m+1}{n} + \frac{r}{s} = -1, \text{ (an integer)} \quad \dots \quad (1)$$

\therefore by Art. 7(A)·4, Case II, we put

$$1+x^3 = z^3 x^3.$$

$$\therefore x^3(z^3 - 1) = 1. \quad \therefore x = \frac{1}{(z^3 - 1)^{1/3}} \quad \dots \quad (2)$$

$$\therefore dx = -\frac{z^2}{(z^3 - 1)^{4/3}} \quad \dots \quad (3)$$

$$\therefore \text{denominator} = x^4 z = \frac{z}{(z^3 - 1)^{4/3}}.$$

$$\therefore I = -\int z dz = -\frac{1}{2}z^2 = -\frac{1}{2} \frac{(1+x^3)^{2/3}}{x^2}.$$

Alternatively. Since (1) is a negative integer, we can put

$$x^{-3} + 1 = z^3.$$

$$\text{Thus, } I = \int \frac{dx}{x^3 \left\{ x^3 \left(1 + \frac{1}{x^3} \right) \right\}^{1/3}} = \int x^{-4} (x^{-3} + 1)^{-1/3} dx.$$

$$\text{Since } x^{-3} + 1 = z^3, \quad \therefore -x^{-4} dx = z^2 dz.$$

$$\therefore I = -\int z^{-1} \cdot z^2 dz = \text{etc.}$$

Ex. 2. Integrate $\int \frac{dx}{(x^2 - 2x + 1) \sqrt{(x^2 - 2x + 3)}}$.

It is of the form Case II of Art. 7(A)·6.

$$\begin{aligned} &= \int \frac{dx}{(x-1)^2 \sqrt{(x-1)^2 + 2}} \\ &= \int \frac{dz}{z^2 \sqrt{z^2 + 2}}, \text{ putting } z = x - 1. \end{aligned}$$

It is of the form of Art. 7(A)·5

$$\begin{aligned} &= \int \frac{\sqrt{2} \sec^2 \theta \, d\theta}{2 \tan^2 \theta \cdot \sqrt{2} \sec \theta}, \text{ putting } z = \sqrt{2} \tan \theta \\ &= \frac{1}{2} \int \operatorname{cosec} \theta \cot \theta \, d\theta \\ &= -\frac{1}{2} \operatorname{cosec} \theta. \end{aligned}$$

Since $\tan \theta = \frac{1}{\sqrt{2}} z$, $\operatorname{cosec} \theta = \frac{\sqrt{z^2+2}}{z}$,

$$\therefore I = -\frac{1}{2} \frac{\sqrt{z^2+2}}{z} = -\frac{1}{2} \frac{\sqrt{x^2-2x+3}}{x-1}.$$

Ex. 3. Integrate the following :

(i) $\int \frac{x^2+1}{x^4+1} dx$. (ii) $\int \frac{x^2-1}{x^4+1} dx$. (iii) $\int \frac{1}{x^4+1} dx$.

(i) $I = \int \frac{1 + \frac{1}{x^2}}{x^2 + \frac{1}{x^2}} dx$ (dividing numerator and denominator by x^2)

$$= \int \frac{\left(1 + \frac{1}{x^2}\right) dx}{\left(x - \frac{1}{x}\right)^2 + 2}$$

$$= \int \frac{dz}{z^2 + 2} \text{ (on putting } x - \frac{1}{x} = z)$$

$$= \frac{1}{\sqrt{2}} \tan^{-1} \frac{z}{\sqrt{2}} = \frac{1}{\sqrt{2}} \tan^{-1} \left(\frac{x^2-1}{x\sqrt{2}} \right).$$

(ii) It is similar to (i).

$$I = \int \frac{\left(1 - \frac{1}{x^2}\right) dx}{x^2 + \frac{1}{x^2}} = \int \frac{1 - \frac{1}{x^2}}{\left(x + \frac{1}{x}\right)^2 - 2} dx$$

$$= \int \frac{dz}{z^2 - 2} \text{ (on putting } x + \frac{1}{x} = z)$$

$$= \frac{1}{2\sqrt{2}} \log \frac{z - \sqrt{2}}{z + \sqrt{2}} = \frac{1}{2\sqrt{2}} \log \frac{x^2+1-x\sqrt{2}}{x^2+1+x\sqrt{2}}.$$

$$\begin{aligned}
 \text{(iii)} \quad I &= \frac{1}{2} \int \frac{(x^2+1) - (x^2-1)}{x^4+1} dx \\
 &= \frac{1}{2} \int \frac{x^2+1}{x^4+1} dx - \frac{1}{2} \int \frac{x^2-1}{x^4+1} dx \\
 &= \frac{1}{2\sqrt{2}} \tan^{-1} \left(\frac{x^2-1}{x\sqrt{2}} \right) - \frac{1}{4\sqrt{2}} \log \frac{x^2+1-x\sqrt{2}}{x^2+1+x\sqrt{2}} \\
 &\quad \text{[by (i) and (ii).]}
 \end{aligned}$$

Ex. 4. Integrate $\int \frac{1-x^2}{1+x^2} \cdot \frac{dx}{\sqrt{(1+x^2+x^4)}}$.

$$\begin{aligned}
 I &= \int \frac{-x^2 \left(1 - \frac{1}{x^2}\right) dx}{x \left(x + \frac{1}{x}\right) \sqrt{x^2 \left(x^2 + \frac{1}{x^2} + 1\right)}} \\
 &= - \int \frac{\left(1 - \frac{1}{x^2}\right) dx}{\left(x + \frac{1}{x}\right) \sqrt{\left(x + \frac{1}{x}\right)^2 - 1}} \\
 &= - \int \frac{dz}{z \sqrt{z^2 - 1}} \quad \text{[putting } x + \frac{1}{x} = z \text{]} \\
 &= \int \frac{\operatorname{cosec} \theta \cot \theta}{\operatorname{cosec} \theta \cot \theta} d\theta \quad \text{[putting } z = \operatorname{cosec} \theta \text{]} \\
 &= \int d\theta = \theta = \operatorname{cosec}^{-1} z \\
 &= \operatorname{cosec}^{-1} \left(\frac{x^2+1}{x} \right) = \sin^{-1} \left(\frac{x}{1+x^2} \right).
 \end{aligned}$$

EXAMPLES VII(A)

Integrate the following :—

1. $\int \frac{1 + \frac{4}{\sqrt{x}}}{\sqrt[4]{x^3} (1 + \sqrt{x})} dx.$ [Put $x = z^4$]
2. $\int \frac{dx}{\sqrt{(x+2)} + \sqrt[4]{(x+2)}}.$ [Put $x+2 = z^4$]
3. $\int \frac{dx}{\sqrt{(2+x)} + (\sqrt{(2+x)})^3}.$

$$4. (i) \int \sqrt{x} (1 + \sqrt[3]{x})^2 dx. \quad (ii) \int \sqrt{(2 + \sqrt{x})} dx.$$

$$5. (i) \int \frac{x^3}{(1+x^2)^{\frac{3}{2}}} dx. \quad (ii) \int \frac{dx}{x^4 (2+x^2)^{\frac{1}{2}}}.$$

$$6. (i) \int \frac{\sqrt[3]{(1+x^3)}}{x^5} dx. \quad (ii) \int \frac{dx}{x^n (1+x^n)^{\frac{1}{n}}}.$$

$$(iii) \int \frac{\sqrt{(1+x^4)}}{x^3} dx.$$

$$7. (i) \int \frac{\sqrt{(x-x^2)}}{x^3} dx. \quad (ii) \int \frac{\sqrt{x} \sqrt{(1-2x)}}{x^4} dx.$$

$$8. (i) \int \frac{dx}{(x^2+1)\sqrt{(x^2+4)}}. \quad (ii) \int \frac{dx}{(x^2-1)\sqrt{(x^2-9)}}.$$

[Put (i) $x=2 \tan \theta$; (ii) $x=3 \sec \theta$.]

$$9. (i) \int \frac{x^2 dx}{(x-1)\sqrt{(x+2)}}. \quad (ii) \int \frac{dx}{(x-2)^{\frac{3}{2}}(x-5)^{\frac{1}{2}}}.$$

$$10. (i) \int \frac{\sqrt{(1+x+x^2)}}{1+x} dx. \quad (ii) \int \frac{\{x + \sqrt{(a^2+x^2)}\}^n}{\sqrt{(a^2+x^2)}} dx.$$

$$11. \int \frac{x^2+2x+4}{(x+1)\sqrt{(x^2+1)}} dx.$$

$$12. \int \frac{dx}{(4x^2+4x+1)\sqrt{(4x^2+4x+5)}}.$$

$$13. \int \frac{dx}{(2x^2+9x+9)\sqrt{(x^2+3x+2)}}.$$

$$14. \int \frac{x+3}{(x^2+5x+7)\sqrt{(x+2)}} dx.$$

$$15. (i) \int \frac{dx}{(x^2+5x+7)\sqrt{(x+2)}}. \quad (ii) \int \frac{(x^2+4x+4)dx}{(x^2+5x+7)\sqrt{(x+2)}}.$$

$$16. (i) \int \frac{x^2+1}{x^4+x^2+1} dx. \quad (ii) \int \frac{x^2-1}{x^4+x^2+1} dx.$$

$$17. \int x^4 + x^2 + 1 \, dx.$$

$$18. \int \frac{1}{x^4 + x^2 + 1} \, dx.$$

$$19. \int \frac{1-x^2}{1+x^2} \sqrt{x^4+1} \, dx.$$

$$20. \int \frac{1+x^2}{1-x^2} \sqrt{1-3x^2+x^4} \, dx.$$

$$21. \int x \frac{(x^2 - x^{-2})}{\sqrt{(x^2 + x^{-2} + 1)}} \, dx.$$

$$22. \int \frac{x^2 + x^{-2}}{x(x^{-2} - x^2)^{\frac{3}{2}}} \, dx.$$

$$23. \int \frac{1+x^{-2}}{\sqrt{(x^2 + x^{-2} - 1)}} \, dx.$$

24. Integrate

$$\int x \sqrt{x^2 + x + 2} \, dx,$$

by the substitution $z = x + \sqrt{x^2 + x + 2}$

and show that the value is $\frac{1}{\sqrt{2}} \log \frac{\sqrt{x^2 + x + 2} + x - \frac{\sqrt{2}}{2}}{\sqrt{x^2 + x + 2} + x + \frac{\sqrt{2}}{2}}$.

25. Integrate

$$\int x \sqrt{x^2 + 2x + 1} \, dx,$$

by the substitution $z = x + \sqrt{x^2 + 2x + 1}$

and show that the value is $2 \tan^{-1}(x + \sqrt{x^2 + 2x + 1})$.

ANSWERS

1. $4 [\tan^{-1}(\sqrt{x}) + \frac{1}{2} \log(1 + \sqrt{x})].$

2. $2(x+2)^{\frac{1}{2}} - 4(x+2)^{\frac{3}{2}} + 4 \log\{1 + (x+2)^{\frac{1}{2}}\}.$

3. $2 \tan^{-1}(2+x)^{\frac{1}{2}}.$

4. (i) $\frac{2}{3}x^{\frac{3}{2}} + \frac{1}{11}x^{\frac{5}{2}} + \frac{1}{13}x^{\frac{7}{2}}.$

4. (ii) $\frac{1}{6} (2+x)^{\frac{5}{2}} - \frac{5}{8} (2+\sqrt{x})^{\frac{5}{2}}$.
5. (i) $\frac{x^2+2}{\sqrt{(x^2+1)}}$ (ii) $-\frac{1}{12} \frac{(2+x^2)^{\frac{3}{2}}}{x^2} + \frac{1}{4} \frac{(2+x^2)^{\frac{1}{2}}}{x}$.
6. (i) $-\frac{1}{4} \frac{(1+x^2)^{\frac{4}{3}}}{x^4}$ (ii) $\frac{1}{1-n} \frac{(1+x^n)^{(n-1)/n}}{x^{n-1}}$.
- (iii) $\frac{1}{2} \left[\log (x^2 + \sqrt{(1+x^4)}) - \frac{\sqrt{(1+x^4)}}{x^2} \right]$.
7. (i) $-\frac{2}{3} \frac{(x-x^2)^{\frac{3}{2}}}{x^3}$ (ii) $-\frac{2}{5} \frac{(1-2x)^{\frac{5}{2}}}{x^{\frac{5}{2}}} - \frac{4}{3} \frac{(1-2x)^{\frac{3}{2}}}{x^{\frac{3}{2}}}$.
8. (i) $\frac{1}{\sqrt{3}} \tan^{-1} \left(\frac{x\sqrt{3}}{\sqrt{(x^2+4)}} \right)$ (ii) $\frac{1}{2\sqrt{2}} \tan^{-1} \left(\frac{\sqrt{(x^2-9)}}{x} \right)$.
9. (i) $\frac{2}{3} (x+2)^{\frac{3}{2}} - 2 (x+2)^{\frac{1}{2}} + \frac{1}{\sqrt{3}} \log \frac{\sqrt{(x+2)} - \sqrt{3}}{\sqrt{(x+2)} + \sqrt{3}}$.
- (ii) $\frac{2}{3} \sqrt{\left(\frac{x-5}{x-2} \right)}$.
10. (i) $\sqrt{(1+x+x^2)} - \frac{1}{2} \sinh^{-1} \left(\frac{2x+1}{\sqrt{3}} \right) - \sinh^{-1} \left(\frac{1-x}{\sqrt{3}(1+x)} \right)$.
- (ii) $\frac{1}{n} [x + \sqrt{(a^2+x^2)}]^n$.
11. $\sqrt{(x^2+1)} + \sinh^{-1} x - \frac{3}{\sqrt{2}} \sinh^{-1} \left(\frac{1-x}{1+x} \right)$.
12. $-\frac{1}{8} \frac{\sqrt{(4x^2+4x+5)}}{2x+1}$.
13. $\frac{2}{3} \sec^{-1} (2x+3) + \frac{1}{3\sqrt{2}} \cosh^{-1} \left(\frac{5+3x}{x+3} \right)$.
14. $\frac{2}{\sqrt{3}} \tan^{-1} \left(\frac{x+1}{\sqrt{3}\sqrt{(x+2)}} \right)$.
15. (i) $\frac{1}{\sqrt{3}} \tan^{-1} \left(\frac{x+1}{\sqrt{3}\sqrt{(x+2)}} \right) - \frac{1}{2} \log \frac{x+3-\sqrt{(x+2)}}{x+3+\sqrt{(x+2)}}$.
- (ii) $2\sqrt{(x+2)} - \frac{2}{\sqrt{3}} \tan^{-1} \left(\frac{x+1}{\sqrt{3}\sqrt{(x+2)}} \right)$.

$$16. \text{ (i) } \frac{1}{\sqrt{3}} \tan^{-1} \frac{x^2-1}{x\sqrt{3}}. \quad \text{(ii) } \frac{1}{2} \log \frac{x^2-x+1}{x^2+x+1}.$$

$$17. \frac{1}{2\sqrt{3}} \tan^{-1} \left(\frac{x^2-1}{x\sqrt{3}} \right) + \frac{1}{4} \log \frac{x^2-x+1}{x^2+x+1}.$$

$$18. \frac{1}{2\sqrt{3}} \tan^{-1} \left(\frac{x^2-1}{x\sqrt{3}} \right) - \frac{1}{4} \log \frac{x^2-x+1}{x^2+x+1}. \quad .$$

$$19. \frac{1}{\sqrt{2}} \sin^{-1} \left(\frac{x\sqrt{2}}{1+x^2} \right). \quad 20. \sin^{-1} \left(\frac{x}{x^2-1} \right). \quad 21. \frac{\sqrt{(x^4+x^2+1)}}{x}.$$

$$22. \frac{x}{\sqrt{(1-x^4)}}. \quad 23. \sinh^{-1} \left(\frac{x^2-1}{x} \right).$$

MISCELLANEOUS EXAMPLES

1. Integrate the following functions with respect to x :—

$$(i) \frac{x^2 + \cos^2 x}{x^2 + 1} \cdot \operatorname{cosec}^2 x.$$

$$(ii) \frac{\sin x}{\sin(x-a)}.$$

$$(iii) \frac{\cos 8x - \cos 7x}{1 + 2 \cos 5x}.$$

$$(iv) \frac{\tan a - \tan x}{\tan a + \tan x}.$$

$$(v) \sec^{\frac{2}{3}} x \operatorname{cosec}^{\frac{2}{3}} x.$$

$$(vi) x^3 (\log x)^2.$$

$$(vii) \sec x \log (\sec x + \tan x).$$

$$(viii) x^3 \cos x.$$

$$(ix) \sec x \tan x \sqrt{2 + \tan^2 x}.$$

$$(x) x \cos^3 x.$$

$$(xi) (\log x)^3. \quad (xii) \tan^{-1}(\sqrt{x}). \quad (xiii) \log(1+x^2).$$

$$(xiv) x^2 \sin^{-1} x. \quad (xv) 2^x \cos x. \quad (xvi) e^x x^4.$$

Integrate the following :—

$$2. (i) \int \left(\frac{x-1}{x^2+1} \right)^2 dx.$$

$$(ii) \int \frac{x^3}{(1+x^2)^3} dx.$$

$$3. (i) \int \frac{\log(1+x)}{x^2} dx.$$

$$(ii) \int \frac{\sin(\log x)}{x^3} dx.$$

$$4. (i) \int \frac{dx}{(e^x + e^{-x})^2}.$$

$$(ii) \int \frac{dx}{(1+e^x)(1+e^{-x})}.$$

$$5. (i) \int (a+x) \sqrt{a^2+x^2} dx.$$

$$(ii) \int (a^2+x^2) \sqrt{a+x} dx.$$

$$6. (i) \int \frac{dx}{(1+x^2)\sqrt{1-x^2}} \quad (ii) \int \frac{dx}{(1-x^2)\sqrt{1+x^2}}$$

$$7. (i) \int \frac{dx}{(x^2-4)\sqrt{x^2-1}} \quad (ii) \int \frac{dx}{(x^2+1)\sqrt{x^2+1}}$$

$$8. (i) \int \frac{dx}{x^2(1+x^2)^2} \quad (ii) \int \frac{dx}{x^2\sqrt{x^2+1}}$$

$$9. (i) \int \frac{dx}{x(x^2+1)} \quad (ii) \int \frac{dx}{x^4\sqrt{x^2+1}}$$

$$10. (i) \int \frac{dx}{x^3\sqrt{x^2-1}} \quad (ii) \int \frac{dx}{x(x+1)^2}$$

$$11. (i) \int \frac{x+4}{x^4(x-1)} dx \quad (ii) \int \frac{\sqrt{x^2+1}}{x^2} dx$$

$$12. (i) \int \frac{x}{1+\sin x} dx \quad (ii) \int e^x \frac{2+\sin 2x}{1+\cos 2x} dx$$

$$13. (i) \int \frac{x \tan^{-1} x}{(1+x^2)^{\frac{3}{2}}} dx \quad (ii) \int \frac{e^{a \tan^{-1} x}}{(1+x^2)^{\frac{3}{2}}} dx$$

$$14. (i) \int \frac{\sqrt{1+\sin 2x}}{1+\cos 2x} dx \quad (ii) \int \frac{dx}{(a \sin x + b \cos x)^2}$$

$$15. (i) \int \frac{dx}{\cos x \cos 2x} \quad (ii) \int \sin \left(2 \tan^{-1} \sqrt{\frac{1-x}{1+x}} \right) dx$$

$$16. (i) \int \frac{\sqrt{x} dx}{(x+1)(x+2)} \quad (ii) \int \frac{dx}{x(x-1)^2(x^2+1)}$$

$$17. (i) \int \frac{x^2 dx}{(x-1)^2(x^2+1)} \quad (ii) \int \frac{dx}{x\sqrt{x^2+x-6}}$$

18. (i) $\int \frac{dx}{\sin x + \tan x}$ (ii) $\int \frac{\sin x \, dx}{3 \cos x + 2 \sin x}$
19. (i) $\int \frac{e^x - n}{e^{-x} + 1} dx$ (ii) $\int \frac{dx}{x \sqrt{(5x^2 - 4x + 1)}}$
20. (i) $\int \frac{(x-1)(x-4)}{(x-2)(x-3)} dx$ (ii) $\int \frac{3x^2 - 2x - 3}{(x-1)(x-2)(x-3)} dx$
21. (i) $\int \frac{dx}{x^4 + 18x^2 + 81}$ (ii) $\int \frac{dx}{(x^2 + 2x + 5)^2}$
22. (i) $\int \frac{dx}{(1+x)^{\frac{3}{2}} + (1+x)^{\frac{1}{2}}}$ (ii) $\int \sqrt{x + \sqrt{x^2 + 2}} \, dx$

Evaluate the following :—

23. (i) $\int_0^1 x^{\frac{3}{2}}(1-x)^{\frac{1}{2}} dx$ (ii) $\int_0^{\frac{1}{2}\pi} x^3 \sin 3x \, dx$
24. (i) $\int_0^1 x \log(1 + \frac{1}{2}x) dx$ (ii) $\int_0^{\pi} \log(1 + \cos x) dx$
25. (i) $\int_0^{\infty} \frac{dx}{(1+x^2)^2}$ (ii) $\int_0^{\infty} \frac{\sqrt{x}}{1+x^2} dx$
26. (i) $\int_1^{\infty} \frac{dx}{x(1+x^2)}$ (ii) $\int_0^{\infty} \frac{x \, dx}{(1+x)(1+x^2)}$
27. (i) $\int_0^1 \frac{dx}{1-x+x^2}$ (ii) $\int_0^1 \frac{dx}{(1+x^2)\sqrt{1-x^2}}$
28. (i) $\int_{-1}^{+1} \frac{x^2 - 1}{(x^2 + 1)^2} dx$ (ii) $\int_1^{\sqrt{2}} \frac{x^2 + 1}{x^4 + 1} dx$

Show that :—

$$29. \int_0^1 \frac{dx}{(1+x)(2+x)} = .288 \text{ nearly.}$$

$$30. \int_0^a \frac{dx}{x + \sqrt{a^2 - x^2}} = \frac{\pi}{4}.$$

$$31. \int_{\frac{1}{2}}^{\frac{3}{2}} \frac{dx}{\sqrt{\{(x-1)(3-x)\}}} = \frac{\pi}{3}.$$

$$32. \int_0^a x \sqrt{\frac{a^2 - x^2}{a^2 + x^2}} dx = \left(\frac{1}{4} \pi - \frac{1}{2} \right) a^2.$$

[Put $x^2 = a^2 \cos 2\theta$]

$$33. \int_0^\pi \frac{dx}{3 + 2 \sin x + \cos x} = \frac{\pi}{4}.$$

$$34. \int_0^\infty \frac{dx}{a^2 e^x + b^2 e^{-x}} = \frac{1}{ab} \tan^{-1} \frac{b}{a}.$$

$$35. \int_0^\infty \log \left(x + \frac{1}{x} \right) \frac{dx}{1+x^2} = \pi \log_e 2.$$

[Put $x = \tan \theta$]

36. If $C_0, C_1, C_2, \dots, C_n$ denote the coefficients in the expansion of $(1+x)^n$ where n is a positive integer, show that

$$\frac{C_0}{1} + \frac{C_1}{2} + \frac{C_2}{3} + \dots + \frac{C_n}{n+1} = \frac{2^{n+1} - 1}{n+1}.$$

ANSWERS

1. (i) $-(\cot x + \tan^{-1} x)$. (ii) $x \cos a + \sin a \log \sin (x-a)$.
 (iii) $\frac{1}{2} \sin 3x - \frac{1}{2} \sin 2x$. (iv) $\sin 2a \log \sin (x+a) - x \cos 2a$.
 (v) $-\frac{2}{3} \cot^{\frac{2}{3}} x$. (vi) $\frac{1}{2} x^4 \{(\log x)^2 - \frac{1}{2} \log x + \frac{1}{8}\}$.

- (vii) $\frac{1}{2} \{\log (\sec x + \tan x)\}^2$.
 (viii) $(x^3 - 6x) \sin x + 3(x^2 - 2) \cos x$.
 (ix) $\frac{1}{2} \sec x \sqrt{1 + \sec^2 x} + \frac{1}{2} \log (\sec x + \sqrt{\sec^2 x + 1})$.
 (x) $\frac{1}{12} x \sin 3x + \frac{1}{36} \cos 3x + \frac{2}{3} x \sin x + \frac{2}{3} \cos x$.
 (xi) $x(l^3 - 3l^2 + 6l - 6)$, where $l = \log x$.
 (xii) $(x+1) \tan^{-1}(\sqrt{x}) - \sqrt{x}$.
 (xiii) $x \log (1+x^2) - 2x + 2 \tan^{-1} x$.
 (xiv) $\frac{1}{3} x^3 \sin^{-1} x + \frac{1}{3} \sqrt{1-x^2} - \frac{1}{9} (1-x^2)^{\frac{3}{2}}$.
 (xv) $\frac{2^x}{\sqrt{1+(\log 2)^2}} \cos \{x - \cot^{-1}(\log 2)\}$.
 (xvi) $e^x (x^4 - 4x^3 + 12x^2 - 24x + 24)$.

2. (i) $\tan^{-1} x + \frac{1}{1+x^2}$. (ii) $-\frac{1+2x^2}{4(1+x^2)^2}$.
3. (i) $\log x - \left(1 + \frac{1}{x}\right) \log (1+x)$. (ii) $-\frac{1}{5} x^{-2} (\cos \log x + 2 \sin \log x)$.
4. (i) $-\frac{1}{2} (1+e^{2x})^{-1}$. (ii) $-(1+e^x)^{-1}$.
5. (i) $\frac{1}{8} (2x^2 + 3ax + 2a^2) \sqrt{a^2 + x^2} + \frac{1}{2} a^3 \log (x + \sqrt{a^2 + x^2})$.
 (ii) $\frac{1}{108} (x+a)^{\frac{3}{2}} (15x^2 - 12ax + 4a^2)$.
6. (i) $\frac{1}{\sqrt{2}} \tan^{-1} \left(\frac{x \sqrt{2}}{\sqrt{1-x^2}} \right)$. (ii) $\frac{1}{2 \sqrt{2}} \log \frac{\sqrt{1+x^2} + x \sqrt{2}}{\sqrt{1+x^2} - x \sqrt{2}}$.
7. (i) $\frac{1}{4 \sqrt{3}} \log \frac{2 \sqrt{x^2-1} - x \sqrt{3}}{2 \sqrt{x^2-1} + x \sqrt{3}}$. (ii) $\frac{1}{\sqrt{3}} \tan^{-1} \left(\frac{x \sqrt{3}}{\sqrt{x^2+4}} \right)$.
8. (i) $-\frac{2+3x^2}{2x(1+x^2)} - \frac{3}{2} \tan^{-1} x$. (ii) $-\frac{\sqrt{1+x^2}}{x}$. 9. (i) $\log \frac{x}{\sqrt{x^2+1}}$.
 (ii) $\frac{2x^2-1}{3x^3} \sqrt{1+x^2}$. 10. (i) $\frac{1}{2} \sec^{-1} x + \frac{\sqrt{x^2-1}}{2x^2}$. (ii) $\log \frac{x}{1+x} - \frac{x}{1+x}$.
11. (i) $\frac{1+3x+6x^2}{3x^3} + 2 \log \frac{x-1}{x}$. (ii) $\log (x + \sqrt{x^2+1}) - \frac{\sqrt{1+x^2}}{x}$.
12. (i) $x(\tan x - \sec x) + \log (1 + \sin x)$. (ii) $e^x \tan x$.

13. (i) $\frac{x - \tan^{-1} x}{\sqrt{1+x^2}}$. (ii) $\frac{(a+x) e^{a \tan^{-1} x}}{(1+a^2) \sqrt{1+x^2}}$.
14. (i) $\frac{1}{2} \{ \sec x + \log (\sec x + \tan x) \}$. (ii) $\frac{-\cos x}{a (a \sin x + b \cos x)}$.
15. (i) $\frac{1}{\sqrt{2}} \log \frac{1 + \sqrt{2} \sin x}{1 - \sqrt{2} \sin x} - \frac{1}{2} \log \frac{1 + \sin x}{1 - \sin x}$.
(ii) $\frac{1}{2} \{ x \sqrt{1-x^2} - \cos^{-1} x \}$.
16. (i) $2 \sqrt{2} \tan^{-1} \sqrt{\frac{x}{2}} - 2 \tan^{-1} \sqrt{x}$.
(ii) $\log \frac{x}{x-1} + \frac{1}{2} \frac{1}{1-x} + \frac{1}{2} \tan^{-1} x$.
17. (i) $\frac{1}{2} \log (x-1) - \frac{1}{2(x-1)} - \frac{1}{4} \log (x^2+1)$.
(ii) $\sqrt{\frac{2}{3}} \cos^{-1} \sqrt{\frac{2(x+3)}{5x}}$.
18. (i) $\frac{1}{2} \log \tan \frac{1}{2} x - \frac{1}{4} \tan^2 \frac{1}{2} x$. (ii) $\frac{1}{11} \{ 2x - 3 \log (3 \cos x + 2 \sin x) \}$.
19. (i) $e^x - (n+1) \log (e^x + 1)$. (ii) $\sinh^{-1} \left(\frac{2x-1}{2} \right)$.
20. (i) $x+2 \{ \log (x-2) - \log (x-3) \}$.
(ii) $9 \log (x-3) - 5 \log (x-2) - \log (x-1)$.
21. (i) $\frac{1}{54} \left\{ \tan^{-1} \frac{1}{3} x + \frac{3x}{x^2+9} \right\}$. (ii) $\frac{1}{16} \tan^{-1} \frac{x+1}{2} + \frac{x+1}{8(x^2+2x+5)}$.
22. (i) $2 \tan^{-1} (1+x)^{\frac{1}{2}}$. (ii) $\frac{2}{3} \frac{x^2+x\sqrt{2+x^2}-2}{\sqrt{x+\sqrt{2+x^2}}}$.
23. (i) $\frac{1}{16} \pi$. (ii) $\frac{2}{27} - \frac{1}{12} \pi^2$. 24. (i) $\frac{3}{4} (1 - 2 \log \frac{3}{2})$. (ii) $\pi \log \frac{1}{2}$.
25. (i) $\frac{1}{4} \pi$. (ii) $\frac{\pi}{\sqrt{2}}$. 26. (i) $\frac{1}{2} \log 2$. (ii) $\frac{1}{4} \pi$.
27. (i) $\frac{2\pi}{9} \sqrt{3}$. (ii) $\frac{\pi}{2\sqrt{2}}$. 28. (i) -1 . (ii) $\frac{1}{\sqrt{2}} \cot^{-1} 2$.
-

CHAPTER VIII
INTEGRATION BY SUCCESSIVE REDUCTION
AND
BETA AND GAMMA FUNCTIONS

8.1. Reduction Formulæ.

It has been mentioned in § 1.6, that in some cases of integration, we take recourse to the method of successive reduction of the integrand, which mostly depends on the repeated application of integration by parts. This is specially the case when the integrands are complicated in nature and depend on certain parameter or parameters. These parameters may be positive, negative or fractional indices, as for example, $x^n e^{ax}$, $\tan^n x$, $(x^2 + a^2)^{\frac{n}{2}}$, $\sin^m x \cos^n x$ etc. To obtain a complete integral of these trigonometric or algebraic functions, we first of all define these integrals by the letters I , J , U etc. introducing the parameter or parameters as suffixes, and connect them with certain similar other integral or integrals whose suffixes are lower than that of the original integral. Then by repeatedly changing the value of the suffixes, the original integral can be made to rest on much simpler integrals. This last integral can be easily evaluated and knowing the value of this last integral, by the process of repeated substitution, the value of the original integral can be found out. The formula in which a certain integral involving some parameters is connected with some integrals of lower order is called a *Reduction Formula*. In most of the cases the reduction formula is obtained by the process of *integration by parts*.

Of course, in some cases the method of differentiation (See § 8'19 below) or other special devices are adopted (See § 8'20). In the next few pages methods of finding the reduction formulæ of certain integrals are discussed.

Case I. Integrals involving one parameter.

8'2. Obtain a reduction formula for $\int x^n e^{ax} dx$.

$$\text{Let } I_n = \int x^n e^{ax} dx. \quad \dots \quad \dots \quad (1)$$

Integrating by parts,

$$\int x^n e^{ax} dx = x^n \cdot \frac{e^{ax}}{a} - \frac{n}{a} \int x^{n-1} e^{ax} dx \quad \dots \quad (2)$$

$$\text{or, } I_n = \frac{x^n e^{ax}}{a} - \frac{n}{a} I_{n-1}. \quad \dots \quad \dots \quad (3)$$

Note 1. It may be observed that the integral on the right-hand side of (2) is of the same form as the integral in (1) except for the power of x , which is $n-1$, and which can be obtained from (1) replacing n by $n-1$ on both sides. If n be a positive integer, proceeding successively as above, I_n will finally depend upon $I_0 = \int e^{ax} dx = e^{ax}/a$, and is thus known.

Note 2. In evaluating (3) from (1), we could integrate x^n first but in that case I_n would have been connected with I_{n+1} , i.e., with an integral whose suffix is greater than that of the original one, which is not usually desirable. A little practice will enable the students to choose the right function.

8'3. Obtain reduction formulæ for

$$(i) \int \sin^n x dx ; \int_0^{\frac{\pi}{2}} \sin^n x dx.$$

$$(ii) \int \cos^n x dx ; \int_0^{\frac{\pi}{2}} \cos^n x dx.$$

(i) As in Article 6·10A(1) of the book,

$$I_n = \int \sin^n x \, dx$$

$$= -\frac{\sin^{n-1} x \cos x}{n} + \frac{n-1}{n} \int \sin^{n-2} x \, dx.$$

$$\therefore I_n = -\frac{\sin^{n-1} x \cos x}{n} + \frac{n-1}{n} I_{n-2} \quad \dots (1)$$

is the required reduction formula.

Also by (1), taking limits of integration from 0 to $\frac{1}{2}\pi$,

$$J_n = \int_0^{\frac{\pi}{2}} \sin^n x \, dx = \frac{n-1}{n} J_{n-2} \quad (n > 1). \quad \dots (2)$$

Similarly,

$$(ii) I_n = \int \cos^n x \, dx = \frac{\cos^{n-1} x \sin x}{n} + \frac{n-1}{n} I_{n-2} \quad \dots (3)$$

and $J_n = \int_0^{\frac{\pi}{2}} \cos^n x \, dx = \frac{n-1}{n} J_{n-2} \quad (n > 1). \quad \dots (4)$

Note. If the integrand be $\sinh^n x$ or $\cosh^n x$, a similar process may be adopted.

8·4. Obtain reduction formulae for

(i) $\int \tan^n x \, dx$; (ii) $\int_0^{\frac{\pi}{4}} \tan^n x \, dx$
(n , a positive integer.)

Here, $I_n = \int \tan^n x \, dx = \int \tan^{n-2} x \cdot \tan^2 x \, dx$

$$= \int \tan^{n-2} x \cdot (\sec^2 x - 1) \, dx$$

$$= \int \tan^{n-2} x \sec^2 x \, dx - \int \tan^{n-2} x \, dx$$

$$= \frac{\tan^{n-1} x}{n-1} - I_{n-2}.$$

Thus,

$$I_n = \frac{\tan^{n-1} x}{n-1} - I_{n-2}. \quad \dots \quad \dots \quad (1)$$

Also, taking limits from 0 to $\frac{1}{4}\pi$,

$$\begin{aligned} J_n &= \int_0^{\frac{\pi}{4}} \tan^n x \, dx = \left[\frac{\tan^{n-1} x}{n-1} \right]_0^{\frac{\pi}{4}} - \int_0^{\frac{\pi}{4}} \tan^{n-2} x \, dx \text{ by (1)} \\ &= \frac{1}{n-1} - J_{n-2}. \quad \dots \quad (2) \end{aligned}$$

Note 1. If n be a positive integer,

$$\int \tan^n x \, dx = \frac{\tan^{n-1} x}{n-1} - \frac{\tan^{n-3} x}{n-3} + \frac{\tan^{n-5} x}{n-5} - \dots$$

If n be odd, the last term is $(-1)^{\frac{1}{2}(n-1)} \int \tan x \, dx$

$$= (-1)^{\frac{1}{2}(n-1)} \log \sec x.$$

If n be even, the last term is $(-1)^{\frac{1}{2}(n+2)} \int \tan^2 x \, dx$

$$= (-1)^{\frac{1}{2}(n+2)} (\tan x - x).$$

Note 2. If the integrand be $\cot^n x$, $\tanh^n x$, $\coth^n x$, the same process may be adopted.

8.5. Obtain a reduction formula for $\int \sec^n x \, dx$.

$$I_n = \int \sec^n x \, dx = \int \sec^{n-2} x \sec^2 x \, dx.$$

Integrating by parts,

$$\begin{aligned} I_n &= \sec^{n-2} x \cdot \tan x \\ &\quad - \int (n-2) \sec^{n-3} x \cdot \sec x \tan x \cdot \tan x \, dx \\ &= \sec^{n-2} x \tan x - (n-2) \int \sec^{n-2} x (\sec^2 x - 1) \, dx \\ &= \sec^{n-2} x \tan x - (n-2) \left[\int \sec^n x \, dx - \int \sec^{n-2} x \, dx \right]. \end{aligned}$$

Transposing and simplifying,

$$I_n = \frac{\sec^{n-2}x \tan x}{n-1} + \frac{n-2}{n-1} I_{n-2}. \quad \dots \quad (1)$$

Note. If the integrands are $\operatorname{cosec}^n x$, $\operatorname{sech}^n x$, $\operatorname{cosech}^n x$, then proceeding as above we can get the reduction formula for each of them.

8.6. Obtain a reduction formula for $\int e^{ax} \cos^n x \, dx$.

Let $I_n = \int e^{ax} \cos^n x \, dx$.

Integrating by parts,

$$\begin{aligned} I_n &= \frac{e^{ax} \cos^n x}{a} + \frac{n}{a} \int e^{ax} \cos^{n-1} x \cdot \sin x \, dx \\ &= \frac{e^{ax} \cos^n x}{a} + \frac{n}{a} \left[\frac{e^{ax}}{a} \cos^{n-1} x \cdot \sin x - \frac{1}{a} \int e^{ax} \right. \\ &\quad \left. \times \left\{ (n-1) \cos^{n-2} x (-\sin x) \cdot \sin x + \cos^{n-1} x \cdot \cos x \right\} dx \right] \\ &= \frac{e^{ax}}{a} \cos^n x + \frac{n e^{ax}}{a^2} \cos^{n-1} x \cdot \sin x \\ &\quad - \frac{n}{a^2} \int e^{ax} \left\{ (n-1) \cos^{n-2} x (\cos^2 x - 1) + \cos^n x \right\} dx \\ &= \frac{e^{ax} \cos^{n-1} x (a \cos x + n \sin x)}{a^2} \\ &\quad - \frac{n}{a^2} \left[n \int e^{ax} \cos^n x \, dx - (n-1) \int e^{ax} \cos^{n-2} x \, dx \right]. \end{aligned}$$

Transposing,

$$\left(1 + \frac{n^2}{a^2}\right) I_n = \frac{e^{ax} \cos^{n-1} x (a \cos x + n \sin x)}{a^2} + \frac{n(n-1)}{a^2} I_{n-2}$$

$$\text{or, } I_n = \frac{e^{ax} \cos^{n-1} x (a \cos x + n \sin x)}{n^2 + a^2} + \frac{n(n-1)}{n^2 + a^2} I_{n-2}.$$

8'7. Obtain a reduction formula for $\int (x^2 + a^2)^n dx$.

$$\text{Let } I_n = \int (x^2 + a^2)^n dx.$$

Integrating by parts (taking 1 as second factor),

$$\begin{aligned} I_n &= x(x^2 + a^2)^n - \int n(x^2 + a^2)^{n-1} \cdot 2x \cdot x dx \\ &= x(x^2 + a^2)^n - 2n \int (x^2 + a^2)^{n-1} (x^2 + a^2 - a^2) dx \\ &= x(x^2 + a^2)^n - 2n \int (x^2 + a^2)^n dx \\ &\quad + 2na^2 \int (x^2 + a^2)^{n-1} dx. \end{aligned}$$

Transposing,

$$(1 + 2n) I_n = x(x^2 + a^2)^n + 2na^2 I_{n-1}.$$

$$\therefore I_n = \frac{x(x^2 + a^2)^n}{2n+1} + \frac{2na^2}{2n+1} I_{n-1}.$$

Note. It may be noted that here n need not be an integer. Put $n = \frac{1}{2}$ and compare with § 3'4(C).

8'8. Obtain a reduction formula for $\int (ax^2 + bx + c)^n dx$.

$$\text{Let } I_n = \int (ax^2 + bx + c)^n dx.$$

If a be positive,

$$\begin{aligned} I_n &= a^n \int (z^2 \pm k^2)^n dx \text{ where } z = x + \frac{b}{2a}, \\ &\quad \text{and } k^2 = \frac{4ac - b^2}{4a^2}; \quad \dots (1) \end{aligned}$$

and if a be negative, say $= -a'$,

$$I_n = (a')^n \int (k^2 - z^2)^n dx,$$

$$\text{where } z = x - \frac{b}{2a'}, \text{ and } k^2 = \frac{4a'c + b^2}{4a'^2}. \quad \dots (2)$$

But (1) and (2) are similar to that of § 8·7 above, and can be evaluated by the same process.

8·9. Obtain a reduction formula for $\int \frac{dx}{(x^2 + a^2)^n}$. [$n \neq 1$]

Let $I_n = \int \frac{dx}{(x^2 + a^2)^n}$, then, $I_{n-1} = \int \frac{dx}{(x^2 + a^2)^{n-1}}$.

Integrating by parts,

$$\begin{aligned} I_{n-1} &= \frac{x}{(x^2 + a^2)^{n-1}} - \int \frac{-(n-1) \cdot 2x \cdot x}{(x^2 + a^2)^n} dx \\ &= \frac{x}{(x^2 + a^2)^{n-1}} + 2(n-1) \int \frac{x^2 + a^2 - a^2}{(x^2 + a^2)^n} dx \\ &= \frac{x}{(x^2 + a^2)^{n-1}} + 2(n-1) I_{n-1} - 2(n-1) a^2 I_n. \end{aligned}$$

Transposing,

$$2(n-1)a^2 I_n = \frac{x}{(x^2 + a^2)^{n-1}} + (2n-3) I_{n-1}$$

$$\text{i.e., } I_n = \frac{1}{2(n-1)a^2} \cdot \frac{x}{(x^2 + a^2)^{n-1}} + \frac{2n-3}{2(n-1)a^2} \cdot I_{n-1}.$$

8·10. Obtain a reduction formula for $\int \frac{dx}{(ax^2 + bx + c)^n}$.

Let $I_n = \int \frac{dx}{(ax^2 + bx + c)^n}$... (1)

If a be positive,

$$I_n = \frac{1}{a^n} \int \frac{dz}{(z^2 \pm k^2)^n}, \quad \text{where } z = x + \frac{b}{2a}, \quad k^2 = \frac{4ac - b^2}{4a^2}, \quad (2)$$

and if a be negative, say $= -a'$,

$$I_n = \frac{1}{(a')^n} \int \frac{dz}{(k^2 - z^2)^n},$$

$$\text{where } z = x - \frac{b}{2a'}, \quad \text{and } k^2 = \frac{4a'c + b^2}{4a'^2}. \quad (3)$$

Both (2) and (3) can be integrated by the same process as in § 8'9 above.

Note. In Article 5'1, Case IV of the book, we have remarked that when the integrand is a rational fraction in which the denominator contains factors real, quadratic but some repeated, in general a reduction formula is required. Thus, to integrate such functions, separate repeated and non-repeated quadratic factors and for repeated quadratic factors, use the result of the above Article.

8'11. Obtain a reduction formula for $\int \frac{x^n dx}{\sqrt{ax^2 + bx + c}}$,

where n is any positive integer.

$$\text{Let } I_n = \int \frac{x^n dx}{\sqrt{ax^2 + bx + c}}$$

$$\text{Noting that, } x^n = \frac{2ax + b}{2a} \cdot x^{n-1},$$

$$I_n = \frac{1}{2a} \int \frac{(2ax + b)}{\sqrt{ax^2 + bx + c}} \cdot x^{n-1} dx - \frac{b}{2a} \int \frac{x^{n-1}}{\sqrt{ax^2 + bx + c}} dx.$$

$$\text{Now, } \int \frac{(2ax + b)}{\sqrt{ax^2 + bx + c}} \cdot x^{n-1} dx$$

$$= 2 \int \sqrt{ax^2 + bx + c} \cdot x^{n-1} - \int 2(n-1)x^{n-2} \sqrt{ax^2 + bx + c} dx$$

$$= 2x^{n-1} \sqrt{ax^2 + bx + c} - 2(n-1) \int \frac{x^{n-2}(ax^2 + bx + c)}{\sqrt{ax^2 + bx + c}} dx$$

$$= 2x^{n-1} \sqrt{ax^2 + bx + c} - 2(n-1) [aI_n + bI_{n-1} + cI_{n-2}].$$

$$\therefore I_n = \frac{x^{n-1}}{a} \sqrt{ax^2 + bx + c} - \frac{n-1}{a} [aI_n + bI_{n-1} + cI_{n-2}]$$

$$- \frac{b}{2a} I_{n-1}$$

$$= \frac{x^{n-1}}{a} \sqrt{ax^2 + bx + c} - (n-1) I_n$$

$$+ \frac{(2n-1)b}{2a} I_{n-1} - \frac{(n-1)c}{a} I_{n-2}.$$

Transposing and simplifying,

$$I_n = \frac{x^{n-1}}{an} \sqrt{ax^2+bx+c} - \frac{(2n-1)b}{2an} I_{n-1} - \frac{(n-1)c}{an} I_{n-2}.$$

Case II. Reduction formulæ involving two parameters.

8·12. Obtain a reduction formula for $\int x^m (\log x)^n dx$
(n, a positive integer).

Here, since two parameters m, n are involved, we shall define the integral by the symbol $I_{m, n}$.

$$I_{m, n} = \int x^m (\log x)^n dx.$$

Integrating by parts,

$$\begin{aligned} I_{m, n} &= \frac{x^{m+1}}{m+1} (\log x)^n - \frac{1}{m+1} \int n(\log x)^{n-1} \cdot \frac{1}{x} \cdot x^{m+1} dx \\ &= \frac{x^{m+1}}{m+1} (\log x)^n - \frac{n}{m+1} \int x^m (\log x)^{n-1} dx \\ &= \frac{x^{m+1}}{m+1} (\log x)^n - \frac{n}{m+1} I_{m, n-1}. \end{aligned}$$

$$i.e., \quad I_{m, n} = \frac{x^{m+1}}{m+1} (\log x)^n - \frac{n}{m+1} I_{m, n-1}.$$

Note 1. Here we have connected, $I_{m, n}$ with $I_{m, n-1}$ and by successive change, the power of $\log x$ can be reduced to zero *i.e.*, after n operations we shall get a term $I_{m, 0}$, *i.e.*, $\int x^m dx$, which is easily integrable. Thus, step by step substitution, $I_{m, n}$ can be evaluated. It may be noted that when two parameters are involved, this is the usual practice.

Note 2. Students must be cautious in defining these integrals. Here as for illustration $I_{m, n} \neq I_{n, m}$.

8.13. Obtain reduction formulæ for

$$(i) \int \frac{(a+bx)^m}{x^n} dx. \quad (ii) \int \frac{dx}{x^m(a+bx)^n}$$

$$(i) \text{ Let } I_{m, n} = \int \frac{(a+bx)^m}{x^n} dx. \quad [n \neq 1]$$

Integrating by parts,

$$I_{m, n} = \frac{(a+bx)^m}{-(n-1)x^{n-1}} + \frac{mb}{n-1} \int \frac{(a+bx)^{m-1}}{x^{n-1}} dx.$$

$$\therefore I_{m, n} = -\frac{(a+bx)^m}{(n-1)x^{n-1}} + \frac{mb}{n-1} I_{m-1, n-1}. \quad \dots (1)$$

$$(ii) \text{ Let } I_{m, n} = \int x^m (a+bx)^{-n} dx.$$

Integrating by parts,

$$I_{m, n} = \frac{1}{-(m-1)x^{m-1}(a+bx)^n} - \frac{nb}{m-1} \int x^{m-1} (a+bx)^{-n-1} dx$$

$$= -\frac{1}{(m-1)x^{m-1}(a+bx)^n} - \frac{n}{m-1} \int \frac{(a+bx) - a}{x^m (a+bx)^{n+1}} dx \quad \dots (2)$$

$$= -\frac{1}{(m-1)x^{m-1}(a+bx)^n} - \frac{n}{m-1} I_{m, n} + \frac{an}{m-1} I_{m, n+1}.$$

$$\therefore \frac{an}{m-1} I_{m, n+1} = \frac{1}{(m-1)x^{m-1}(a+bx)^n} + \frac{m+n-1}{m-1} I_{m, n}.$$

Changing n to $n-1$ on both sides,

$$I_{m, n} = \frac{1}{a(n-1)x^{m-1}(a+bx)^{n-1}} + \frac{m+n-2}{(n-1)a} I_{m, n-1}. \quad \dots (3)$$

Note. Formula (2) or (3) can be taken as the reduction formula for (ii). (3) is more rapidly converging. The other ways in which these integrals can be expressed are left to the students. [See also § 2.2. Ex. 9.]

8·14. Obtain reduction formulæ for

$$(i) \int x^m(1-x)^n dx. \quad (ii) \int_0^1 x^m(1-x)^n dx.$$

$$\begin{aligned} (i) \text{ Let } I_{m, n} &= \int x^m(1-x)^n dx \\ &= \frac{x^{m+1}}{m+1} \cdot (1-x)^n + \frac{n}{m+1} \int x^{m+1} \cdot (1-x)^{n-1} dx \\ &= \frac{x^{m+1}(1-x)^n}{m+1} + \frac{n}{m+1} \int x^{m+1} \cdot (1-x)^{n-1} \{1 - (1-x)\} dx \\ &= \frac{x^{m+1}(1-x)^n}{m+1} + \frac{n}{m+1} [I_{m, n-1} - I_{m, n}]. \end{aligned}$$

Transposing and simplifying,

$$I_{m, n} = \frac{x^{m+1}(1-x)^n}{m+n+1} + \frac{n}{m+n+1} I_{m, n-1}.$$

$$\begin{aligned} (ii) \text{ If } J_{m, n} &= \int_0^1 x^m(1-x)^n dx, \text{ by above, this} \\ &= \left[\frac{x^{m+1}(1-x)^n}{m+n+1} \right]_0^1 + \frac{n}{m+n+1} J_{m, n-1}. \end{aligned}$$

$$\therefore J_{m, n} = \frac{n}{m+n+1} J_{m, n-1}.$$

Note. In Integral Calculus $J_{m, n}$ is usually denoted as $\beta_{m, n}$, the *first Eulerian integral*. It is also referred to as the **Beta-function**.

[See § 8·21 below]

It is interesting to note that $J_{m, n} = J_{n, m}$, i.e., $\beta_{m, n} = \beta_{n, m}$, although $I_{m, n} \neq I_{n, m}$.

8·15. Obtain reduction formulæ for

$$(i) I_{m, n} = \int \sin^m x \cos^n x dx ;$$

$$(ii) J_{m, n} = \int_0^{\frac{1}{2}\pi} \sin^m x \cos^n x dx \quad (m, n \text{ being positive integers}).$$

In Article 6'10, Case B of the book, we have discussed* it fully and obtained

$$I_{m, n} = \frac{\sin^{m+1}x \cos^{n-1}x}{m+n} + \frac{n-1}{m+n} I_{m, n-2}$$

or,
$$= -\frac{\sin^{m-1}x \cos^{n+1}x}{m+n} + \frac{m-1}{m+n} I_{m-2, n}$$
 in a similar

way, and, when m and n are positive integers,

$$J_{m, n} = \frac{n-1}{m+n} J_{m, n-2} = \frac{m-1}{m+n} J_{m-2, n}.$$

Using § 6'8(iv), we also see that $J_{m, n} = J_{n, m}$.

8'16. Obtain a reduction formula for $\int \frac{\sin^m x}{\cos^n x} dx$. [$n \neq 1$]

Let
$$I_{m, n} = \int \sin^m x \cos^{-n} x dx. \quad \dots \quad \dots \quad (1)$$

Consider
$$I'_{p, q} = \int \sin^p x \cos^q x dx$$

$$= \frac{\sin^{p+1}x \cos^{q-1}x}{p+q} + \frac{q-1}{p+q} I'_{p, q-2}.$$

[by § 8'15 above]

Changing q to $q+2$,

$$I'_{p, q+2} = \frac{\sin^{p+1}x \cos^{q+1}x}{p+q+2} + \frac{q+1}{p+q+2} I'_{p, q}.$$

Transposing,

$$I'_{p, q} = -\frac{\sin^{p+1}x \cos^{q+1}x}{q+1} + \frac{p+q+2}{q+1} I'_{p, q+2}. \quad \dots \quad (2)$$

[$q+1 \neq 0$]

Now, replace p by m and q by $-n$ in (2) and use the definition (1).

Then, (2) becomes

$$I_{m, n} = \frac{1}{n-1} \cdot \frac{\sin^{m+1}x}{\cos^{n-1}x} - \frac{m-n+2}{n-1} I_{m, n-2}.$$

8·17. Obtain a reduction formula for $\int \frac{dx}{\sin^m x \cos^n x}$. [$n \neq 1$]

Let $I_{m, n} = \int \frac{dx}{\sin^m x \cos^n x}$.

Consider as before,

$$\begin{aligned} I'_{p, q} &= \int \sin^p x \cos^q x \, dx \\ &= -\frac{\sin^{p+1} x \cos^{q+1} x}{q+1} + \frac{p+q+2}{q+1} I'_{p, q+2}. \end{aligned}$$

[as in § 8·16(2) above]

Replacing p by $-m$ and q by $-n$ and using the def. $I_{m, n}$,

$$I_{m, n} = \frac{1}{n-1} \cdot \frac{1}{\sin^{m-1} x \cos^{n-1} x} + \frac{m+n-2}{n-1} I_{m, n-2}.$$

8·18. Obtain a reduction formula for

$$I_{m, n} = \int \cos^m x \cos nx \, dx,$$

connecting with (i) $I_{m-1, n-1}$, (ii) $I_{m-2, n}$. ($m \neq \pm n$)

(i) Let

$$\begin{aligned} I_{m, n} &= \int \cos^m x \cos nx \, dx \\ &= \frac{\cos^m x \cdot \sin nx}{n} - \frac{m}{n} \int \cos^{m-1} x \cdot (-\sin x) \sin nx \, dx. \end{aligned}$$

... (1)

Since, $\sin nx \sin x = \cos (n-1)x - \cos nx \cos x$,

$$\begin{aligned} \therefore I_{m, n} &= \frac{\cos^m x \sin nx}{n} + \frac{m}{n} \int \cos^{m-1} x \cdot \{ \cos (n-1)x \\ &\quad - \cos nx \cos x \} dx \\ &= \frac{\cos^m x \sin nx}{n} + \frac{m}{n} \left[I_{m-1, n-1} - I_{m, n} \right]. \end{aligned}$$

Simplifying,

$$I_{m, n} = \frac{\cos^m x \sin nx}{m+n} + \frac{m}{m+n} I_{m-1, n-1}.$$

(ii) From (1),

$$I_{m, n} = \frac{\cos^m x \sin nx}{n} + \frac{m}{n} \int (\cos^{m-1} x \sin x) \cdot \sin nx \, dx.$$

Again integrating by parts,

$$\begin{aligned} I_{m, n} &= \frac{\cos^m x \sin nx}{n} + \frac{m}{n} \left[- \frac{\cos^{m-1} x \sin x \cos nx}{n} \right. \\ &\quad \left. + \frac{1}{n} \int \{ (m-1) \cos^{m-2} x (-\sin x) \cdot \sin x \right. \\ &\quad \left. + \cos^{m-1} x \cdot \cos x \} \cos nx \, dx \right] \\ &= \frac{\cos^m x \sin nx}{n} - \frac{m(\cos^{m-1} x \cos nx \sin x)}{n^2} \\ &\quad + \frac{m}{n^2} \int \{ (m-1) \cos^{m-2} x (\cos^2 x - 1) \\ &\quad \quad \quad + \cos^m x \} \cos nx \, dx \\ &= \frac{\cos^{m-1} x (n \sin nx \cos x - m \cos nx \sin x)}{n^2} \\ &\quad + \frac{m}{n^2} \int \{ (m-1+1) \cos^m x \cos nx \\ &\quad \quad \quad - (m-1) \cos^{m-2} x \cos nx \} dx \\ &= \frac{\cos^{m-1} x (n \sin nx \cos x - m \cos nx \sin x)}{n^2} \\ &\quad + \frac{m}{n^2} \left[m I_{m, n} - (m-1) I_{m-2, n} \right]. \end{aligned}$$

Transposing and dividing,

$$I_{m, n} = \frac{n \sin nx \cos x - m \cos nx \sin x}{n^2 - m^2} \cdot \cos^{m-1} x - \frac{m(m-1)}{n^2 - m^2} I_{m-2, n}.$$

There are three other integrals of a similar type.

(i) $\int \cos^m x \sin nx \, dx$, (ii) $\int \sin^m x \cos nx \, dx$,

and (iii) $\int \sin^m x \sin nx \, dx$,

which can be treated in a similar manner, and connected by a reduction formula either with $I_{m-1, n-1}$ or with $I_{m-2, n}$ in each case.

For instance,

$$(m+n) \int \cos^m x \sin nx \, dx = -\cos^m x \cos nx + m I_{m-1, n-1};$$

$$\begin{aligned} (n^2 - m^2) \int \sin^m x \cos nx \, dx \\ = (n \sin nx \sin x + m \cos nx \cos x) \sin^{m-1} x - m(m-1) I_{m-2, n}; \text{ etc.} \end{aligned}$$

Case III. Special devices.

8·19. Obtain a reduction formula for $\int \frac{dx}{(a + b \cos x)^n}$.

Let $I_n = \int \frac{dx}{(a + b \cos x)^n}$.

Consider $P = \frac{\sin x}{(a + b \cos x)^{n-1}} \dots \dots (1)$

$$\begin{aligned} \therefore \frac{dP}{dx} \\ = \frac{\cos x(a + b \cos x)^{n-1} - (n-1)(a + b \cos x)^{n-2}(-b \sin x) \cdot \sin x}{\{(a + b \cos x)^{n-1}\}^2} \end{aligned}$$

$$\begin{aligned}
&= \frac{\cos x (a + b \cos x) + (n-1)b(1 - \cos^2 x)}{(a + b \cos x)^n} \\
&= \frac{(n-1)b + a \cos x - (n-2)b \cos^2 x}{(a + b \cos x)^n} \\
&= \frac{A + B(a + b \cos x) + C(a + b \cos x)^2}{(a + b \cos x)^n} \text{ (say) } \dots (2)
\end{aligned}$$

Then comparing the coefficients,

$$A + B.a + Ca^2 = (n-1)b, B.b + 2Cab = a, Cb^2 = -(n-2)b.$$

Solving,

$$A = -(n-1) \frac{a^2 - b^2}{b}, B = (2n-3) \frac{a}{b}, C = -\frac{n-2}{b} \dots (3)$$

\therefore substituting these values of A, B, C in (2), we get

$$\begin{aligned}
\frac{dP}{dx} &= -\frac{(n-1)(a^2 - b^2)}{b} \cdot \frac{1}{(a + b \cos x)^n} \\
&+ \frac{(2n-3)a}{b} \cdot \frac{1}{(a + b \cos x)^{n-1}} - \frac{n-2}{b} \cdot \frac{1}{(a + b \cos x)^{n-2}}.
\end{aligned}$$

Integrating both sides with respect to x , and using the definition of I_n ,

$$P = -\frac{(n-1)(a^2 - b^2)}{b} I_n + \frac{(2n-3)a}{b} I_{n-1} - \frac{n-2}{b} I_{n-2}.$$

$$\begin{aligned}
\therefore I_n &= -\frac{b}{(n-1)(a^2 - b^2)} \cdot \frac{\sin x}{(a + b \cos x)^{n-1}} \\
&+ \frac{(2n-3)a}{(n-1)(a^2 - b^2)} I_{n-1} - \frac{(n-2)}{(n-1)(a^2 - b^2)} I_{n-2}.
\end{aligned}$$

Alternative method.

$$\text{Let } P = \frac{\sin x}{(a + b \cos x)^{n-1}} \text{ and } V = a + b \cos x.$$

$$\therefore \cos x = \frac{V-a}{b},$$

$$\begin{aligned} \therefore \frac{dP}{dx} &= \frac{d}{dx} \left(\frac{\sin x}{V^{n-1}} \right) = \frac{\cos x}{V^{n-1}} - (n-1) \sin x \frac{(-b \sin x)}{V^n} \\ &= \frac{V-a}{b V^{n-1}} + \frac{(n-1)b}{V^n} \left[1 - \left(\frac{V-a}{b} \right)^2 \right] \\ &= -\frac{(n-1)(a^2 - b^2)}{b V^n} + \frac{a(2n-3)}{b V^{n-1}} - \frac{(n-2)}{b V^{n-2}}. \end{aligned}$$

Integrating both sides *w. r. t. x* and using the definition $I_n = \int \frac{dx}{V^n}$, the result follows.

Note. When n is a positive integer, by a repeated application of the above reduction formula, I_n will ultimately depend on I_1 , which is easily integrable (See § 4.2).

8.20. Obtain reduction formulae for $\int x^m(a+bx^n)^p dx$.

In this integral, usually denoted as *binomial differentials*, three parameters are involved and this integral, written as

$$I_{m, n, p} = \int x^m (a + bx^n)^p dx$$

can be connected with any one of the integrals below :

(i) $I_{m+n, n, p-1} = \int x^{m+n} (a + bx^n)^{p-1} dx.$

(ii) $I_{m, n, p-1} = \int x^m (a + bx^n)^{p-1} dx.$

(iii) $I_{m, n, p+1} = \int x^m (a + bx^n)^{p+1} dx.$

(iv) $I_{m-n, n, p+1} = \int x^{m-n} (a + bx^n)^{p+1} dx.$

(v) $I_{m-n, n, p} = \int x^{m-n} (a + bx^n)^p dx.$

(vi) $I_{m+n, n, p} = \int x^{m+n} (a + bx^n)^p dx.$

(i) $I_{m, n, p} = \int x^m (a + bx^n)^p dx$. Integrating by parts,

$$\begin{aligned} I_{m, n, p} &= \frac{x^{m+1}}{m+1} (a + bx^n)^p \\ &\quad - \frac{1}{m+1} \int p(a + bx^n)^{p-1} \cdot nbx^{n-1} \cdot x^{m+1} dx \\ &= \frac{x^{m+1}}{m+1} (a + bx^n)^p - \frac{nbp}{m+1} I_{m+n, n, p-1}. \quad (1) \end{aligned}$$

Again, as above,

$$\begin{aligned} I_{m, n, p} &= \frac{x^{m+1}}{m+1} (a + bx^n)^p \\ &\quad - \frac{nbp}{m+1} \int \frac{x^m}{b} (a + bx^n - a)(a + bx^n)^{p-1} dx. \\ &\quad \left[\text{writing } x^{m+n} = \frac{1}{b} x^m (a + bx^n - a) \right] \end{aligned}$$

Transposing and simplifying,

$$I_{m, n, p} = \frac{x^{m+1} (a + bx^n)^p}{np + m + 1} + \frac{anp}{np + m + 1} I_{m, n, p-1}. \quad (2)$$

Changing p to $p+1$ in (2) and transposing, we get a connection with the integral (iii), viz.,

$$\begin{aligned} I_{m, n, p} &= - \frac{x^{m+1} (a + bx^n)^{p+1}}{an(p+1)} \\ &\quad + \frac{n(p+1) + m + 1}{an(p+1)} I_{m, n, p+1}. \quad \dots \quad (3) \end{aligned}$$

Also changing m to $(m-n)$ and p to $p+1$ in (1) and transposing, we get

$$\begin{aligned} I_{m, n, p} &= \frac{x^{m-n+1} (a + bx^n)^{p+1}}{nb(p+1)} \\ &\quad - \frac{m-n+1}{nb(p+1)} I_{m-n, n, p+1}. \quad \dots \quad (4) \end{aligned}$$

To get a connection with $I_{m-n, n, p}$ and $I_{m+n, n, p}$ write

$$x^m = \int \left(x^{m-n+1} \cdot nbx^{n-1} \right)$$

$$\therefore I_{m, n, p} = \frac{1}{nb} \int x^{m-n+1} \cdot (a + bx^n)^p \cdot nb \cdot x^{n-1} dx.$$

Integrating by parts and simplifying,

$$I_{m, n, p} = \frac{x^{m-n+1} (a + bx^n)^{p+1}}{b(np + m + 1)} - \frac{a(m - n + 1)}{b(np + m + 1)} I_{m-n, n, p} \dots \quad (5)$$

Changing m to $m + n$ in (5) and transposing,

$$I_{m, n, p} = \frac{x^{m+1} (a + bx^n)^{p+1}}{a(m + 1)} - \frac{b(np + m + n + 1)}{a(m + 1)} I_{m+n, n, p} \dots \quad (6)$$

These six formulæ of $I_{m, n, p}$ can be obtained by another method.

Write $P = x^{\lambda+1} (a + bx^n)^{\mu+1}$,

where λ and μ are the smaller indices of x and $(a + bx^n)$ respectively in the two expressions whose integrals are to be connected.

Find $\frac{dP}{dx}$ and express it as linear combination of the two integrands. On integration the result can be obtained.

To illustrate the above statements we shall find a connection of $I_{m, n, p}$ with $I_{m+n, n, p}$.

Here evidently $\lambda = m$, $\mu = p$. $\therefore P = x^{m+1}(a + bx^n)^{p+1}$.

$$\begin{aligned}\therefore \frac{dP}{dx} &= (m+1)x^m(a + bx^n)^{p+1} + (p+1)x^{m+1} \cdot nbx^{n-1}(a + bx^n)^p \\ &= (m+1)x^m(a + bx^n)^p(a + bx^n) + nb(p+1)x^{m+n}(a + bx^n)^p \\ &= (m+1)ax^m(a + bx^n)^p + b(np + n + m + 1)x^{m+n}(a + bx^n)^p.\end{aligned}$$

Integrating with respect to x ,

$$\begin{aligned}P &= (m+1)a I_{m, n, p} + b(np + n + m + 1) I_{m+n, n, p} \\ \therefore I_{m, n, p} &= \frac{x^{m+1}(a + bx^n)^{p+1}}{a(m+1)} - \frac{b(np + n + m + 1)}{a(m+1)} I_{m+n, n, p}\end{aligned}$$

which is the same as (6).

Similarly the other five results can be obtained.

For another illustration see sum no. 7, § 8'22.

8'21. Beta and Gamma Functions.

In many problems in the applications of Integral Calculus, the use of the Beta and Gamma functions often facilitates calculations. So we give below an account of those functions—their definitions and important properties, some of which are however mentioned without any proof.*

Definitions :

$$(A) \int_0^1 x^{m-1} (1-x)^{n-1} dx \text{ denoted by } \mathbf{B}(m, n)$$

$$[m > 0, n > 0]$$

is called the *First Eulerian integral* or **Beta function**.

*Results (v), (vi) and (viii) are given without any proof here, as the proofs are based on "double integration" which is beyond the scope of the present book. Nevertheless, the results are extremely important in applications and are to be carefully remembered.

$$(B) \int_0^{\infty} e^{-x} x^{n-1} dx \text{ denoted by } \Gamma(n) \quad [n > 0]$$

is called the *Second Eulerian integral* or **Gamma function**.

Here m and n are positive but they need not be integers.

Properties :

(i) By property (iv) of Art. 6'8, we get

$$\int_0^1 x^{m-1} (1-x)^{n-1} dx = \int_0^1 x^{n-1} (1-x)^{m-1} dx.$$

$$\therefore B(m, n) = B(n, m).$$

$$(ii) \Gamma(1) = \int_0^{\infty} e^{-x} dx = 1.$$

[See Ex. 1, Illustrative Examples Art. 7'2]

$$\therefore \Gamma(1) = 1.$$

(iii) As in Ex. 9, Illustrative Examples Art. 7'2, it can be shown that even when n is not a positive integer,

$$\int_0^{\infty} e^{-x} x^n dx = n \int_0^{\infty} e^{-x} x^{n-1} dx.$$

$$\therefore \Gamma(n+1) = n\Gamma(n).$$

When n is a positive integer,

$$\Gamma(n+1) = n!$$

(iv) Writing kx for x in (B), we easily get

$$\int_0^{\infty} e^{-kx} x^{n-1} dx = \frac{\Gamma(n)}{k^n}. \quad [k > 0, n > 0]$$

$$(v) B(m, n) = \frac{\Gamma(m) \Gamma(n)}{\Gamma(m+n)}.$$

$$(vi) \Gamma(m) \Gamma(1-m) = \frac{\pi}{\sin m\pi} \quad (0 < m < 1).$$

(vii) Putting $m = \frac{1}{2}$ in (vi), we get

$$\Gamma\left(\frac{1}{2}\right) \Gamma\left(\frac{1}{2}\right) = \frac{\pi}{\sin \frac{1}{2}\pi} = \pi$$

$$\therefore \Gamma\left(\frac{1}{2}\right) = \sqrt{\pi}.$$

Alternatively, we can deduce the value of $\Gamma\left(\frac{1}{2}\right)$ in the following way.

Putting $m = n = \frac{1}{2}$ in (v),

$$\begin{aligned} \frac{\Gamma\left(\frac{1}{2}\right) \Gamma\left(\frac{1}{2}\right)}{\Gamma(1)} &= B\left(\frac{1}{2}, \frac{1}{2}\right) = \int_0^1 x^{-\frac{1}{2}}(1-x)^{-\frac{1}{2}} dx \\ &= 2 \int_0^{\frac{1}{2}\pi} d\theta \quad [\text{on putting } x = \sin^2 \theta] \\ &= \pi. \end{aligned}$$

Hence the result.

$$(viii) B(m, n) = \int_0^{\infty} \frac{x^{m-1}}{(1+x)^{m+n}} = \int_0^{\infty} \frac{x^{n-1}}{(1+x)^{m+n}} \quad [m > 0, n > 0]$$

8.21 (A). Standard Integrals.

$$(1) \int_0^{\frac{1}{2}\pi} \sin^p \theta \cos^q \theta d\theta = \frac{\Gamma\left(\frac{p+1}{2}\right) \Gamma\left(\frac{q+1}{2}\right)}{2\Gamma\left(\frac{p+q+2}{2}\right)}, \quad \left[\begin{array}{l} p > -1 \\ q > -1 \end{array} \right]$$

$$\begin{aligned} \text{Left side} &= \int_0^{\frac{1}{2}\pi} (\sin^2 \theta)^{\frac{p}{2}} (1 - \sin^2 \theta)^{\frac{q}{2}} d\theta \\ &= \frac{1}{2} \int_0^1 x^{\frac{p+1}{2}-1} (1-x)^{\frac{q+1}{2}-1} dx \\ & \quad [\text{on putting } x = \sin^2 \theta] \\ &= \frac{1}{2} B\left(\frac{p+1}{2}, \frac{q+1}{2}\right) = \text{Right side by (v)}. \end{aligned}$$

[Compare § 6.10B]

$$(2) \int_0^{\frac{1}{2}\pi} \sin^p \theta \, d\theta = \int_0^{\frac{1}{2}\pi} \cos^p \theta \, d\theta = \frac{\sqrt{\pi}}{2} \cdot \frac{\Gamma\left(\frac{p+1}{2}\right)}{\Gamma\left(\frac{p+2}{2}\right)}$$

The proof is similar to (1) [Compare § 6·10A]

$$(3) \int_0^{\infty} e^{-x^2} \, dx = \frac{1}{2} \sqrt{\pi}.$$

$$\text{Left side} = \frac{1}{2} \int_0^{\infty} e^{-z} z^{\frac{1}{2}-1} \, dz \quad [\text{on putting } x^2 = z]$$

$$= \frac{1}{2} \Gamma\left(\frac{1}{2}\right) \text{ by (B)} = \frac{1}{2} \sqrt{\pi} \text{ by (vii).}$$

[Compare Art. 7·3]

8·22. Illustrative Examples.

Ex. 1. Obtain a reduction formula for $\int \tan^n x \, dx$ and hence or

otherwise find (i) $\int \tan^5 x \, dx$ (ii) $\int \tan^9 x \, dx$.

$$\text{From § 8·4 formula (i),} \quad I_n = \int \tan^n x \, dx = \frac{\tan^{n-1} x}{n-1} - I_{n-2}.$$

$$(i) \quad \therefore I_5 = \int \tan^5 x \, dx = \frac{1}{3} \tan^4 x - I_3$$

$$I_3 = \frac{1}{3} \tan^2 x - I_1 \text{ where } I_1 = \int \tan x \, dx = \log \sec x.$$

$$\therefore I_5 = \frac{1}{3} \tan^4 x - \frac{1}{3} \tan^2 x + \log \sec x.$$

$$(ii) \quad I_9 = \frac{1}{7} \tan^8 x - I_7 ; I_7 = \frac{1}{5} \tan^6 x - I_5$$

$$I_5 = \frac{\tan^4 x}{1} - I_3 \text{ where } I_3 = \int dx = x$$

$$\therefore I_9 = \frac{\tan^8 x}{5} - \frac{\tan^6 x}{3} + \frac{\tan^4 x}{1} - x.$$

[Compare § 8·4, Note 1 in these two cases.]

Ex. 2. Obtain a reduction formula for $\int \sec^n x \, dx$.

Hence find (i) $\int \sec^6 x \, dx$ (ii) $\int \sec^7 x \, dx$.

From § 8'5, $I_n = \int \sec^n x \, dx = \frac{\sec^{n-2} x \tan x}{n-1} + \frac{n-2}{n-1} I_{n-2}$.

$$(i) \therefore I_6 = \int \sec^6 x \, dx = \frac{\sec^4 x \tan x}{5} + \frac{4}{5} I_4$$

$$I_4 = \frac{\sec^2 x \tan x}{3} + \frac{2}{3} I_2; \quad I_2 = \int \sec^2 x \, dx = \tan x.$$

$$\therefore I_6 = \frac{\sec^4 x \tan x}{5} + \frac{4}{5} \cdot \frac{\sec^2 x \tan x}{3} + \frac{2.4}{3.5} \tan x.$$

$$(ii) \text{ Also } I_7 = \int \sec^7 x \, dx = \frac{\sec^5 x \tan x}{6} + \frac{5}{6} I_5;$$

$$I_5 = \frac{\sec^3 x \tan x}{4} + \frac{3}{4} I_3; \quad I_3 = \frac{\sec x \tan x}{2} + \frac{1}{2} I_1;$$

$$I_1 = \int \sec x \, dx = \log (\sec x + \tan x).$$

$$\begin{aligned} \therefore I_7 = \frac{\sec^5 x \tan x}{6} + \frac{5}{6} \cdot \frac{\sec^3 x \tan x}{4} + \frac{3.5}{4.6} \cdot \frac{\sec x \tan x}{2} \\ + \frac{1.3.5}{2.4.6} \log (\sec x + \tan x). \end{aligned}$$

Ex. 3. Obtain a reduction formula for $\int_0^\infty e^{-ax} \cos^n x \, dx$ ($a > 0$) and hence find the value of $\int_0^\infty e^{-4x} \cos^6 x \, dx$.

From § 8'6, replacing a by $-a$,

$$\begin{aligned} I_n &= \int_0^\infty e^{-ax} \cos^n x \, dx \\ &= \left[\frac{e^{-ax} \cos^{n-1} x (-a \cos x + n \sin x)}{n^2 + a^2} \right]_0^\infty + \frac{n(n-1)}{n^2 + a^2} I_{n-2} \\ &= \frac{a}{n^2 + a^2} + \frac{n(n-1)}{n^2 + a^2} I_{n-2} \left[\because \lim_{x \rightarrow \infty} e^{-ax} \rightarrow 0 \text{ for } a > 0 \right] \end{aligned}$$

is the reqd. reduction formula.

$$\therefore I_3 = \frac{4}{5^2+4^2} + \frac{5.4}{5^2+4^2} I_3 = \frac{4}{41} + \frac{20}{41} I_3;$$

$$I_3 = \frac{4}{3^2+4^2} + \frac{3.2}{3^2+4^2} I_1 = \frac{4}{25} + \frac{6}{25} I_1;$$

$$I_1 = \frac{4}{1^2+4^2} = \frac{4}{17}; \quad \therefore I_3 = \frac{708}{3485}.$$

Ex. 4. Obtain a reduction formula for $\int \frac{dx}{(x^2+a^2)^{\frac{n}{2}}}$.

Hence find the value of $\int \frac{dx}{(x^2+a^2)^{\frac{7}{2}}}$.

Let $I_n = \int \frac{dx}{(x^2+a^2)^{\frac{n}{2}}}$. Integrating by parts,

$$I_n = \frac{x}{(x^2+a^2)^{\frac{n}{2}}} + \frac{n}{2} \int \frac{x}{(x^2+a^2)^{\frac{n}{2}+1}} \cdot 2x dx$$

$$= \frac{x}{(x^2+a^2)^{\frac{n}{2}}} + n \int \frac{x^2+a^2-a^2}{(x^2+a^2)^{\frac{n}{2}+1}} dx$$

$$= \frac{x}{(x^2+a^2)^{\frac{n}{2}}} + n I_n - n a^2 I_{n+2}.$$

Changing n to $n-2$ on both sides,

$$I_{n-2} = \frac{x}{(x^2+a^2)^{\frac{n-2}{2}}} + (n-2) I_{n-2} - (n-2) a^2 I_n$$

$$\therefore I_n = \frac{1}{(n-2)a^2} \cdot \frac{x}{(x^2+a^2)^{\frac{n-2}{2}}} + \frac{n-3}{(n-2)a^2} I_{n-2}.$$

This result can be obtained from § 8.7, by substituting $-\frac{n}{2}$ in place of n and changing the definition of I_n .

$$\therefore I_7 = \int \frac{dx}{(x^2+a^2)^{\frac{7}{2}}} = \frac{1}{5a^2} \cdot \frac{x}{(x^2+a^2)^{\frac{5}{2}}} + \frac{4}{5a^2} I_5;$$

$$I_5 = \frac{1}{3a^2} \cdot \frac{x}{(x^2+a^2)^{\frac{3}{2}}} + \frac{2}{3a^2} I_3; \quad I_3 = \frac{1}{a^2} \cdot \frac{x}{(x^2+a^2)^{\frac{1}{2}}}.$$

$$\therefore I_7 = \frac{1}{5a^2} \cdot \frac{x}{(x^2+a^2)^{\frac{5}{2}}} + \frac{4}{3.5.a^4} \cdot \frac{x}{(x^2+a^2)^{\frac{3}{2}}} + \frac{2.4}{3.5.a^6} \cdot \frac{x}{(x^2+a^2)^{\frac{1}{2}}}.$$

Ex. 5. With the help of a reduction formula, find the value of

$$\int \frac{\sin^5 x}{\cos^6 x} dx.$$

From § 8·16, we get the general form of the reduction formula as

$$I_{m, n} \equiv \int \frac{\sin^m x}{\cos^n x} dx = \frac{1}{n-1} \frac{\sin^{m+1} x}{\cos^{n-1} x} - \frac{m-n+2}{n-1} I_{m, n-2} \quad [n \neq 1]$$

$$\therefore I_{5, 6} = \frac{1}{5} \cdot \frac{\sin^6 x}{\cos^6 x} - \frac{1}{5} I_{5, 4}; \quad I_{5, 4} = \frac{1}{3} \frac{\sin^6 x}{\cos^4 x} - \frac{3}{3} I_{5, 2};$$

$$I_{5, 2} = \frac{\sin^6 x}{\cos^2 x} - \frac{5}{1} I_{5, 0}; \quad \text{Also } I_{5, 0} = \int \sin^5 x dx \\ = -\frac{\sin^4 x \cos x}{5} - \frac{4}{5} \frac{\sin^2 x \cos x}{3} - \frac{4}{5} \cdot \frac{2}{3} \cdot \cos x$$

[From § 8·3(i)]

$$\therefore I_{5, 6} = \frac{1}{5} \frac{\sin^6 x}{\cos^6 x} - \frac{1}{15} \frac{\sin^6 x}{\cos^4 x} + \frac{1}{5} \frac{\sin^6 x}{\cos^2 x} \\ + \frac{1}{5} \sin^4 x \cos x + \frac{4}{5} \cdot \frac{\sin^2 x \cos x}{3} + \frac{4}{5} \cdot \frac{2}{3} \cdot \cos x.$$

Ex. 6. From the reduction formula for $\int \cos^m x \cos nx dx$ obtain

$$\int \cos^3 x \cos 5x dx.$$

$$\text{From § 8·18 (i), } I_{m, n} = \int \cos^m x \cos nx dx \\ = \frac{\cos^m x \sin nx}{m+n} + \frac{m}{m+n} I_{m-1, n-1}.$$

Here, $m=3$, $n=5$;

$$\therefore I_{3, 5} = \int \cos^3 x \cos 5x dx = \frac{\cos^3 x \sin 5x}{8} + \frac{3}{8} I_{2, 4};$$

$$I_{2, 4} = \frac{\cos^2 x \sin 4x}{6} + \frac{2}{6} I_{1, 3}; \quad I_{1, 3} = \frac{\cos x \sin 3x}{4} + \frac{1}{4} I_{0, 2};$$

$$I_{0, 2} = \int \cos 2x dx = \frac{\sin 2x}{2}.$$

$$\therefore I_{3, 5} = \frac{\cos^3 x \sin 5x}{8} + \frac{\cos^2 x \sin 4x}{16} + \frac{\cos x \sin 3x}{32} + \frac{\sin 2x}{64}.$$

Ex. 7. With the help of the different reduction formulæ for

$$\int x^m (a + bx^n)^p dx, \text{ find the value of}$$

$$(i) \int x^3 (a + bx^2)^4 dx. \quad (ii) \int \frac{x^3}{(a + bx^2)^4} dx.$$

(i) Here, $m = 3$, $n = 2$, $p = 4$, and since $p = 4$ is positive,

\therefore (i) can be connected with § 8.20 (1) or (2).

Using (1),

$$I_{3, 2, 4} = \frac{x^4 (a + bx^2)^4}{4} - \frac{2 \cdot b \cdot 4}{4} I_{5, 2, 3}$$

$$I_{5, 2, 3} = \frac{x^6 (a + bx^2)^3}{6} - \frac{2 \cdot b \cdot 3}{6} I_{7, 2, 2}$$

$$I_{7, 2, 2} = \frac{x^8 (a + bx^2)^2}{8} - \frac{2 \cdot b \cdot 2}{8} I_{9, 2, 1}$$

$$I_{9, 2, 1} = \frac{x^{10} (a + bx^2)}{10} - \frac{2 \cdot b}{10} I_{11, 2, 0}$$

$$I_{11, 2, 0} = \int x^{11} dx = \frac{x^{12}}{12}$$

$$\begin{aligned} \therefore I_{3, 2, 4} &= \frac{x^4 (a + bx^2)^4}{4} - \frac{bx^6 (a + bx^2)^3}{4} + \frac{b^2 x^8 (a + bx^2)^2}{4} \\ &\quad - \frac{b^3 x^{10} (a + bx^2)}{10} + \frac{b^4 \cdot x^{12}}{5 \cdot 12}. \end{aligned}$$

Using § 8.20(2) the result can be obtained in a different form.

(ii) For this, the suitable formulæ are § 8.20 (3) or (4).

Using (3), replacing p by -4 ,

$$\begin{aligned} I_{3, 2, 4} &= \frac{1}{2a(-3)} \frac{x^4}{(a + bx^2)^3} + \frac{2(-3) + 3 + 1}{2a(-3)} I_{3, 2, 3} \\ &= \frac{1}{6a} \frac{x^4}{(a + bx^2)^3} + \frac{1}{3a} I_{3, 2, 3}; \end{aligned}$$

$$\begin{aligned} I_{3, 2, 3} &= -\frac{x^4}{2a(-2)} \frac{1}{(a + bx^2)^2} + \frac{2(-2) + 3 + 1}{2a(-2)} I_{3, 2, 2} \\ &= \frac{x^4}{4a(a + bx^2)^2}. \end{aligned}$$

$$\therefore I_{3, 2, 4} = \frac{1}{6a} \frac{x^4}{(a + bx^2)^3} + \frac{1}{12a^2} \frac{x^4}{(a + bx^2)^2}.$$

Ex. 8. Find the reduction formula for $\int \frac{x^m dx}{(a+2bx+cx^2)^n}$ ($n \neq -1$), and hence obtain $\int_0^2 \frac{x^3 dx}{(x^2-4x+5)^4}$.

$$\text{Let } I_{m, n} = \int \frac{x^m dx}{(a+2bx+cx^2)^n}.$$

Consider $I_{m-2, n} = \int \frac{x^{m-2} dx}{(a+2bx+cx^2)^n}$. Integrating by parts,

$$\begin{aligned} I_{m-2, n} &= \frac{x^{m-1}}{(m-1)(a+2bx+cx^2)^n} + \frac{n}{m-1} \int \frac{x^{m-1}(2cx+2b)}{(a+2bx+cx^2)^{n+1}} dx \\ &= \frac{x^{m-1}}{(m-1)(a+2bx+cx^2)^n} + \frac{n}{m-1} \left\{ 2c \int \frac{x^m dx}{(a+2bx+cx^2)^{n+1}} \right. \\ &\quad \left. + 2b \int \frac{x^{m-1} dx}{(a+2bx+cx^2)^{n+1}} \right\}. \end{aligned}$$

Changing n to $(n-1)$ on both sides,

$$I_{m-2, n-1} = \frac{x^{m-1}}{(m-1)(a+2bx+cx^2)^{n-1}} + \frac{n-1}{m-1} [2c I_{m, n} + 2b I_{m-1, n}]$$

Dividing and transposing,

$$\begin{aligned} I_{m, n} &= -\frac{x^{m-1}}{2c(n-1)(a+2bx+cx^2)^{n-1}} \\ &\quad + \frac{n-1}{2c(n-1)} I_{m-2, n-1} - \frac{b}{c} I_{m-1, n} \quad \dots \quad (1) \end{aligned}$$

$$\begin{aligned} \text{Also, } I_{m-2, n-1} &= \int \frac{x^{m-2} dx}{(a+2bx+cx^2)^{n-1}} = \int \frac{x^{m-2}(a+2bx+cx^2)}{(a+2bx+cx^2)^n} dx \\ &= a I_{m-2, n} + 2b I_{m-1, n} + c I_{m, n}. \end{aligned}$$

Substituting and simplifying,

$$\begin{aligned} I_{m, n} &= -\frac{x^{m-1}}{c(2n-m-1)(a+2bx+cx^2)^{n-1}} + \frac{2b(m-n)}{c(2n-m-1)} I_{m-1, n} \\ &\quad + \frac{a(m-1)}{c(2n-m-1)} I_{m-2, n} \quad \dots \quad (2) \end{aligned}$$

Either of (1) or (2), may be regarded as a reduction formula.

Hence, using (2), ($a=5, b=-2, c=1$, here),

$$I_{3,4} = \left[-\frac{x^2}{4(x^2-4x+5)^2} \right]_0^2 + \frac{-4(-1)}{4} I_{2,4} + \frac{5 \cdot 2}{9} I_{1,4}$$

$$I_{2,4} = \left[-\frac{x}{5(x^2-4x+5)^2} \right]_0^2 + \frac{-4(-2)}{5} I_{1,4} + \frac{5}{5} I_{0,4}$$

$$I_{1,4} = \left[-\frac{1}{6(x^2-4x+5)^2} \right]_0^2 + \frac{-4(-3)}{6} I_{0,4}$$

$$\begin{aligned} I_{0,4} &= \int_0^2 \frac{dx}{(x^2-4x+5)^2} = \int_0^2 \frac{dx}{\{(x-2)^2+1\}^2} \\ &= \int_0^2 \frac{dz}{(z^2+1)^2} \quad [\text{Putting } z=2-x] \\ &= \frac{433}{3000} + \frac{5}{16} \tan^{-1} 2 \quad [\text{Using } \S 8.9 \text{ successively}] = \lambda \text{ (say)}. \end{aligned}$$

Then, $I_{1,4} = -\frac{124}{6 \cdot 5^2} + 2\lambda$

$$I_{2,4} = -\frac{2}{5} - \frac{124 \times 4}{3 \cdot 5^4} + \frac{21}{5} \lambda$$

$$\begin{aligned} I_{3,4} &= -\frac{3896}{3 \cdot 5^4} + \frac{46}{5} \lambda \\ &= -\frac{3896}{3 \cdot 5^4} + \frac{46 \times 433}{3 \cdot 5^4 \cdot 8} + \frac{46}{16} \tan^{-1} 2 \\ &= -\frac{3}{4} + \frac{23}{8} \tan^{-1} 2. \end{aligned}$$

Ex. 9. If $u_n = \int_0^{\frac{\pi}{2}} x^n \sin x \, dx$ ($n > 0$), prove that

$$u_n + n(n-1) u_{n-2} = n\left(\frac{1}{2}\pi\right)^{n+1}.$$

Integrating by parts,

$$\begin{aligned} u_n &= \left[-x^n \cos x \right]_0^{\frac{\pi}{2}} + n \int_0^{\frac{\pi}{2}} x^{n-1} \cos x \, dx \\ &= n \left\{ \left[x^{n-1} \sin x \right]_0^{\frac{\pi}{2}} - (n-1) \int_0^{\frac{\pi}{2}} x^{n-2} \sin x \, dx \right\} \\ &= n\left(\frac{1}{2}\pi\right)^{n-1} - n(n-1) u_{n-2}. \end{aligned}$$

$$\therefore u_n + n(n-1) u_{n-2} = n\left(\frac{1}{2}\pi\right)^{n-1}.$$

Ex. 10. If $S_n = \int_0^{\frac{1}{2}\pi} \frac{\sin(2n-1)x}{\sin x} dx$, $V_n = \int_0^{\frac{1}{2}\pi} \left(\frac{\sin nx}{\sin x}\right)^2 dx$, n being an integer, show that

$$S_{n+1} = S_n = \frac{1}{2}\pi, \quad V_{n+1} - V_n = S_{n+1}.$$

Obtain the value of V_n .

$$\begin{aligned} \text{Here, } S_{n+1} - S_n &= \int_0^{\frac{\pi}{2}} \frac{\sin(2n+1)x - \sin(2n-1)x}{\sin x} dx \\ &= \int_0^{\frac{\pi}{2}} \frac{2 \cos 2nx \cdot \sin x}{\sin x} dx = 2 \int_0^{\frac{\pi}{2}} \cos 2nx dx \\ &= 2 \cdot \left[\frac{\sin 2nx}{2n} \right]_0^{\frac{\pi}{2}} = 0 \text{ for all integral values of } n. \end{aligned}$$

$$\therefore S_{n+1} = S_n = S_{n-1} \dots = S_1.$$

$$\text{Now, } S_1 = \int_0^{\frac{\pi}{2}} \frac{\sin x}{\sin x} dx = \int_0^{\frac{\pi}{2}} dx = \frac{\pi}{2}.$$

$$\therefore S_{n+1} = S_n = \frac{1}{2}\pi.$$

$$\begin{aligned} \text{Also, } V_{n+1} - V_n &= \int_0^{\frac{\pi}{2}} \frac{\sin^2(n+1)x - \sin^2 nx}{\sin^2 x} dx \\ &= \int_0^{\frac{\pi}{2}} \frac{\frac{1}{2} \sin(2n+1)x \cdot \sin x}{\sin^2 x} dx \\ &= \int_0^{\frac{\pi}{2}} \frac{\sin(2n+1)x}{\sin x} dx = S_{n+1}. \end{aligned}$$

$$\therefore V_n - V_{n-1} = S_n = \frac{1}{2}\pi, \quad V_{n-1} - V_{n-2} = \frac{1}{2}\pi, \dots, \quad V_2 - V_1 = \frac{1}{2}\pi.$$

$$\therefore \text{ adding, } V_n - V_1 = (n-1) \frac{\pi}{2}.$$

$$\text{Since, } V_1 = \int_0^{\frac{\pi}{2}} dx = \frac{1}{2}\pi, \quad \therefore V_n = \frac{1}{2}n\pi.$$

Ex. 11. Show that

$$(i) \Gamma\left(\frac{1}{2}\right) = \frac{1}{\sqrt{2}} \sqrt{\pi};$$

$$(ii) \Gamma\left(\frac{1}{3}\right)\Gamma\left(\frac{2}{3}\right) = \frac{2}{\sqrt{3}} \pi;$$

$$(iii) \int_0^{\frac{1}{2}\pi} \sin^4 \theta \cos^4 \theta d\theta = \int_0^{\frac{1}{2}\pi} \sin^6 \theta \cos^4 \theta d\theta = \frac{2}{15} \pi.$$

(i) $\Gamma\left(\frac{7}{2}\right) = \Gamma\left(\frac{5}{2} + 1\right) = \frac{5}{2}\Gamma\left(\frac{5}{2}\right)$ [$\because \Gamma(n+1) = n\Gamma(n)$ Art. 8·21(iii)]
 $= \frac{5}{2}\Gamma\left(\frac{3}{2} + 1\right) = \frac{5}{2} \cdot \frac{3}{2} \cdot \Gamma\left(\frac{3}{2}\right) = \frac{5}{2} \cdot \frac{3}{2} \cdot \Gamma\left(\frac{1}{2} + 1\right) = \frac{5}{2} \cdot \frac{3}{2} \cdot \frac{1}{2}\Gamma\left(\frac{1}{2}\right)$
 $= \frac{15}{8}\sqrt{\pi}$. [By Art. 8·21(vii)]

(ii) Left side = $\Gamma\left(\frac{1}{3}\right)\Gamma\left(1 - \frac{1}{3}\right) = \frac{\pi}{\sin \frac{1}{3}\pi}$ [By Art 8·21(vi)] = $\frac{2}{\sqrt{3}}\pi$.

(iii) By Art. 8·21(A)(1),

First Integral = $\frac{1}{2} \cdot \frac{\Gamma\left(\frac{5}{2}\right)\Gamma\left(\frac{7}{2}\right)}{\Gamma(6)} = \frac{\frac{1}{2} \cdot \frac{5}{2} \cdot \frac{1}{2} \sqrt{\pi} \cdot \frac{5}{2} \cdot \frac{3}{2} \cdot \frac{1}{2} \sqrt{\pi}}{5!} = \frac{3}{512}\pi$.

By Art. 6·8(iv), Second Integral = First Integral.

Ex. 12. Show that

$$\Gamma\left(n + \frac{1}{2}\right) = \frac{\Gamma(2n+1)\sqrt{\pi}}{2^{2n}\Gamma(n+1)}$$

$$\begin{aligned} \Gamma\left(n + \frac{1}{2}\right) &= \Gamma\left(\frac{2n+1}{2}\right) = \Gamma\left(\frac{2n-1}{2} + 1\right) \\ &= \frac{2n-1}{2} \Gamma\left(\frac{2n-1}{2}\right) \quad [\text{By Art. 8·21(iii)}] \\ &= \frac{2n-1}{2} \Gamma\left(\frac{2n-3}{2} + 1\right) \\ &= \frac{2n-1}{2} \cdot \frac{2n-3}{2} \Gamma\left(\frac{2n-3}{2}\right) \\ &= \frac{2n-1}{2} \cdot \frac{2n-3}{2} \cdot \frac{2n-5}{2} \dots \frac{5}{2} \cdot \frac{3}{2} \cdot \frac{1}{2} \Gamma\left(\frac{1}{2}\right) \\ &\quad [\text{By repeated application of the result} \\ &\quad \text{of the above Article.}] \\ &= \frac{(2n-1)(2n-3)(2n-5) \dots 5 \cdot 3 \cdot 1}{2^n} \sqrt{\pi}. \quad \dots (1) \end{aligned}$$

Now, multiply numerator and denominator of (1) by

$$2n(2n-2)(2n-4) \dots 4 \cdot 2.$$

$$\begin{aligned} \therefore \Gamma\left(n + \frac{1}{2}\right) &= \frac{2n(2n-1)(2n-2)(2n-3) \dots 5 \cdot 4 \cdot 3 \cdot 2 \cdot 1}{2^n \cdot 2 \cdot n \cdot 2(n-1) \cdot 2(n-2) \dots 2 \cdot 2 \cdot 2 \cdot 1} \sqrt{\pi} \\ &= \frac{\Gamma(2n+1)}{2^n \cdot 2^n \cdot n(n-1)(n-2) \dots 2 \cdot 1} \sqrt{\pi} \\ &= \frac{\Gamma(2n+1)\sqrt{\pi}}{2^{2n} \cdot \Gamma(n+1)}. \end{aligned}$$

Note 1. The above result can be written in the form

$$\Gamma\left(\frac{1}{2}\right)\Gamma(2n) = 2^{2n-1}\Gamma(n)\Gamma\left(n + \frac{1}{2}\right).$$

It is an important result often used in Higher Mathematics.

Note 2. The right side of (1) can be written as $\left(\frac{1}{2}\right)_n\Gamma\left(\frac{1}{2}\right)$ where the notation $(a)_n$ denotes $a(a+1)(a+2)\cdots(a+n-1)$.

$$\therefore \Gamma\left(n + \frac{1}{2}\right) = \left(\frac{1}{2}\right)_n\Gamma\left(\frac{1}{2}\right).$$

Ex. 13. Show that

$$B(m, n) B(m+n, l) = B(n, l) B(n+l, m).$$

$$\text{Left side} = \frac{\Gamma(m)\Gamma(n)}{\Gamma(m+n)} \cdot \frac{\Gamma(m+n)\Gamma(l)}{\Gamma(l+m+n)} = \frac{\Gamma(l)\Gamma(m)\Gamma(n)}{\Gamma(l+m+n)}.$$

$$\text{Similarly, right side} = \frac{\Gamma(l)\Gamma(m)\Gamma(n)}{\Gamma(l+m+n)}.$$

Hence the result.

Ex. 14. Evaluate

$$\int_0^t x^{\alpha+k-1}(t-x)^{\beta+k-1} dx$$

and find its value when $\alpha = \beta = \frac{1}{2}$.

Put $x = ty$, $\therefore dx = t dy$; when $x = 0$, $y = 0$; $x = t$, $y = 1$.

$$\therefore I = \int_0^1 t^{\alpha+\beta+2k-1} y^{\alpha+k-1} (1-y)^{\beta+k-1} dy$$

$$= t^{\alpha+\beta+2k-1} \cdot \frac{\Gamma(\alpha+k)\Gamma(\beta+k)}{\Gamma(\alpha+\beta+2k)}.$$

When $\alpha = \beta = \frac{1}{2}$,

$$I = t^{2k} \cdot \frac{\Gamma\left(k + \frac{1}{2}\right)\Gamma\left(k + \frac{1}{2}\right)}{\Gamma(2k+1)}$$

$$= t^{2k} \cdot \frac{\Gamma(2k+1) \cdot \sqrt{\pi} \left(\frac{1}{2}\right)_k \Gamma\left(\frac{1}{2}\right)}{2^{2k} \Gamma(2k+1) \Gamma(k+1)} \quad [\text{By Ex 12 and Note (2) above}]$$

[By Ex. 12 and the Note (2) of Art. 8'22]

$$= t^{2k} \cdot \frac{\left(\frac{1}{2}\right)_k \pi}{2^{2k} k!}.$$

EXAMPLES VIII

1. Obtain a reduction formula for $\int x^n e^{-ax} dx$, ($n \neq -1$) and hence find $\int x^4 e^{-ax} dx$.

2. Show that $\int x^3 e^{ax} dx = \frac{e^{ax}}{a^4} (a^3 x^3 - 3a^2 x^2 + 6ax - 6)$.

3. Find the reduction formula for

(i) $\int \cot^n x dx$. (ii) $\int \operatorname{cosec}^n x dx$.

4. If $I_n = \int \sinh^n \theta d\theta$, then show that

$$nI_n = \sinh^{n-1} \theta \cosh \theta - (n-1)I_{n-2}.$$

5. Obtain the reduction formula for

(i) $\int \tanh^n \theta d\theta$. (ii) $\int \operatorname{sech}^n \theta d\theta$.

6. Show that if $I_n = \int e^{ax} \sin^n bx dx$, then

$$I_n = \frac{a \sin bx - nb \cos bx}{a^2 + n^2 b^2} e^{ax} \sin^{n-1} bx + \frac{n(n-1)b^2}{a^2 + n^2 b^2} I_{n-2}.$$

7. If $I_n = \int x^n \cos bx dx$ and $J_n = \int x^n \sin bx dx$, then show that

(i) $bI_n = x^n \sin bx - nJ_{n-1}$.

(ii) $bJ_n = -x^n \cos bx + nI_{n-1}$.

(iii) $b^2 I_n = x^{n-1} (bx \sin bx + n \cos bx) - n(n-1)I_{n-2}$.

(iv) $b^2 J_n = x^{n-1} (n \sin bx - bx \cos bx) - n(n-1)J_{n-2}$.

8. Find the values of the integrals :

(i) $\int (x^2 - 6x + 7)^5 dx$. (ii) $\int \frac{dx}{(x^2 + 1)^{\frac{3}{2}}}$.

(iii) $\int \frac{dx}{(x^2 + x + 1)^{\frac{3}{2}}}$. (iv) $\int \frac{x^3 dx}{\sqrt{x^2 - 2x + 2}}$.

9. Show that

$$I_n = \int (a^2 + x^2)^{\frac{n}{2}} dx = \frac{x(a^2 + x^2)^{\frac{n}{2}}}{n+1} + \frac{na^2}{n+1} I_{n-2} ;$$

find also I_3 .

10. If $I_n = \int (1+x^2)^n e^{ax} dx$, ($n > 1$), deduce that

$$\begin{aligned} I_n - \frac{2n(2n-1)}{a^2} I_{n-1} + \frac{4n(n-1)}{a^2} I_{n-2} \\ = \frac{1}{a} e^{ax}(1+x^2)^n - \frac{2nx}{a^2} e^{ax}(1+x^2)^{n-1}. \end{aligned}$$

11. Show that if $u_n = \int x^n \sqrt{a^2 - x^2} dx$, then

$$u_n = -\frac{x^{n-1}(a^2 - x^2)^{\frac{3}{2}}}{n+2} + \frac{n-1}{n+2} a^2 u_{n-2}.$$

12. Find the reduction formula for

$$(i) \int \frac{x^n dx}{\sqrt{2ax - x^2}} \quad (ii) \int \frac{dx}{x^n \sqrt{x^2 - 1}}.$$

13. If $I_n = \int x^n \sqrt{a-x} dx$, prove that

$$(2n+3)I_n = 2anI_{n-1} - 2x^n(a-x)^{\frac{3}{2}}.$$

Hence, evaluate $\int_0^a x^3 \sqrt{ax-x^2} dx$.

14. If $u_n = \int \frac{x^n dx}{\sqrt{ax^2+bx+c}}$, show that

$$(n+1)au_{n+1} + \frac{1}{2}(2n+1)bu_n + ncu_{n-1} = x^n \sqrt{ax^2+bx+c}.$$

15. If $I_n = \int (\sin x + \cos x)^n dx$, then

$$nI_n = -(\sin x + \cos x)^{n-2} \cos 2x + 2(n-1)I_{n-2}.$$

16. Show that

$$(i) I_n = \int_0^c \frac{dx}{(1+x^2)^n} = \frac{2n-3}{2n-2} I_{n-1}.$$

$$(ii) \int_0^\infty \frac{dx}{(1+x^2)^5} = \frac{1.3.5.7}{2.4.6.8} \frac{\pi}{2}.$$

17. Show that if $I_n = \int_0^{\frac{\pi}{2}} \cos^n x dx$ and $J_n = \int_0^{\frac{\pi}{2}} \sin^n x dx$,

$$(i) I_n = J_n. \quad (ii) I_n = \frac{n-1}{n} I_{n-2} \quad (n > 2).$$

18. With a suitable substitution, using the previous example, find the values of

$$(i) \int_0^1 \frac{x^n}{\sqrt{1-x^2}} dx. \quad (ii) \int_0^\infty \frac{dx}{(1+x^2)^n}.$$

(n being a positive integer.)

19. Prove that $u_n = \int_0^1 x^n \tan^{-1} x dx$, then

$$(n+1)u_n + (n-1)u_{n-2} = \frac{\pi}{2} - \frac{1}{n}.$$

20. If $n \geq 2$ and $I_n = \int_{-1}^{+1} (1-x^2)^n \cos mx dx$,

$$\text{then } m^2 I_n = 2n(2n-1)I_{n-1} - 4n(n-1)I_{n-2}.$$

21. If $U_n = \int_0^{\frac{\pi}{2}} \theta \sin^n \theta d\theta$ and $n > 1$, prove that

$$U_n = \frac{n-1}{n} U_{n-2} + \frac{1}{n^2}.$$

22. (i) Obtain a reduction formula for $\int \frac{dx}{(1+x^2)^n \sqrt{1+x^2}}$

$$\text{and (ii) find } \int_0^\infty \frac{dx}{(1+x^2)^n \sqrt{1+x^2}} \quad [\text{Put } x = \tan \theta$$

23. If $\phi(n) = \int_0^\infty e^{-x} x^{n-1} \log x dx$, show that

$$\phi(n+2) - (2n+1)\phi(n+1) + n^2\phi(n) = 0.$$

24. If $I_n = \int_0^{\frac{\pi}{4}} \tan^n \theta d\theta$, prove that

$$n(I_{n+1} + I_{n-1}) = 1.$$

25. Show that $\int_0^1 x^{\alpha-1} (\log x)^n dx = \frac{(-1)^n n!}{\alpha^{n+1}}$.

26. Show that if $\beta_{m, n} = \int_0^1 x^{m-1}(1-x)^{n-1} dx$, then

$$\beta_{m, n} = \beta_{n, m} = \frac{(m-1)!(n-1)!}{(m+n-1)!}$$

(m and n being integers, each > 1).

27. If m, n are positive integers, then

$$I_{m, n} = \int_a^b (x-a)^m (b-x)^n dx = \frac{n(b-a)}{m+n+1} I_{m, n-1}.$$

Hence, prove $I_{m, n} = \frac{m! n! (b-a)^{m+n+1}}{(m+n+1)!}$.

28. Find the values of

$$(i) \int_0^{\frac{\pi}{2}} \sin^6 x \cos^8 x dx. \quad (ii) \int_0^{\frac{\pi}{2}} \sin^{\frac{3}{2}} x \cos^3 x dx.$$

$$(iii) \int \frac{\cos^5 x}{\sin^4 x} dx. \quad (iv) \int \frac{dx}{\sin^{\frac{5}{3}} x \cos^{\frac{7}{3}} x}.$$

29. If $I_{m, n} = \int \cos^m x \sin^n x dx$, show that

$$\begin{aligned} & (m+n)(m+n-2)I_{m, n} \\ &= \{(n-1) \sin^2 x - (m-1) \cos^2 x\} \cos^{m-1} x \sin^{n-1} x \\ & \quad + (m-1)(n-1)I_{m-2, n-2}. \end{aligned}$$

30. Obtain a reduction formula for

$I_{m, n} = \int \cos^m x \sin nx dx$, and deduce the value of

$$\int_0^{\frac{1}{2}\pi} \cos^5 x \sin 3x dx.$$

31. If $I_{m, n} = \int \sin^m x \cos nx dx$, show that

$$I_{m, n} = \frac{m \cos x \cos nx + n \sin x \sin nx}{n^2 - m^2} \sin^{m-1} x$$

$$\frac{m(m-1)}{n^2 - m^2} I_{m-2, n}.$$

32. If $I_{m, n} = \int_0^{\frac{\pi}{2}} \sin^m x \cos nx \, dx$ and

$$J_{m, n} = \int_0^{\frac{\pi}{2}} \sin^m x \sin nx \, dx, \text{ show that}$$

$$(m+n)I_{m, n} = \sin \frac{1}{2}n\pi - mJ_{m-1, n-1} \quad (m > 1).$$

33. If $f(m, n) = \int_0^{\frac{\pi}{2}} \cos^m x \cos nx \, dx$, show that

$$f(m, n) = \frac{m}{m+n} f(m-1, n-1) = \frac{m(m-1)}{m^2-n^2} f(m-2, n)$$

$$= \frac{m}{m-n} f(m-1, n+1),$$

and hence show that $f(m, m) = \frac{\pi}{2^{m+1}}$.

34. Obtain a reduction formula for $\int (a + b \sin x)^n \, dx$.

35. Find the values of

$$(i) \int_0^{\pi} \frac{dx}{(1 + \cos a \cos x)^3}, \quad (ii) \int (1 + e \sin x)^2 \, dx \quad (e < 1).$$

36. Using the integral $\int x^m (a + bx^2)^p \, dx$, find the values of

$$(i) \int x^5 (1 + x^2)^{\frac{7}{2}} \, dx, \quad (ii) \int \frac{x^5}{(1 + 2x^2)^{\frac{1}{2}}} \, dx.$$

[Use § 8.20(5)]

[Use § 8.20(4)]

$$(iii) \int_{\frac{1}{2}}^1 \frac{dx}{x^2 \sqrt{1-x^2}}. \quad [\text{Use § 8.20(6)}]$$

37. Find the reduction formula for $\int x^m \sqrt{2ax - x^2} \, dx$.

Hence, show that $\int_0^{2a} x^m \sqrt{2ax - x^2} \, dx = \pi \frac{a^{m+2}}{2^m} \cdot \frac{(2m+1)!}{(m+2)! m!}$.

38. If $I_m = \int_0^{\infty} x^m e^{-x} \cos x \, dx$ and

$$J_m = \int_0^{\infty} x^m e^{-x} \sin x \, dx,$$

then prove that (m being an integer > 1)

(i) $I_m = \frac{1}{2}m(I_{m-1} - J_{m-1})$. (ii) $J_m = \frac{1}{2}m(I_{m-1} + J_{m-1})$.

(iii) $I_m - mI_{m-1} + \frac{1}{2}m(m-1)I_{m-2} = 0$.

39. Show that $\int_0^{\frac{1}{2}\pi} \sin 2nx \cot x \, dx = \frac{1}{2}\pi$.

40. (i) If $u_n = \int \cos n\theta \operatorname{cosec} \theta \, d\theta$, then show that

$$u_n - u_{n-2} = \frac{2 \cos (n-1)\theta}{n-1}.$$

(ii) If $P_n = \int \frac{\sin (2n-1)x}{\sin x} \, dx$, $Q_n = \int \frac{\sin^2 nx}{\sin^2 x} \, dx$,

show that $n(P_{n+1} - P_n) = \sin 2nx$

and $Q_{n+1} - Q_n = P_{n+1}$.

41. Prove that if

$$J_n = \int_0^{\pi} \frac{1 - \cos nx}{1 - \cos x} \, dx, \text{ where } n \text{ is a positive integer}$$

or zero, then $J_{n+2} + J_n = 2J_{n+1}$.

Hence, prove that $\int_0^{\frac{\pi}{2}} \frac{\sin^2 n\theta}{\sin^2 \theta} \, d\theta = \frac{n\pi}{2}$.

42. (i) Prove that $\int_0^{\pi} \frac{\sin n\theta}{\sin \theta} \, d\theta = 0$, or, π according as n is an even or odd positive integer.

(ii) By means of a reduction formula or otherwise, prove that

$$\int_0^{\pi} \frac{\sin^2 n\theta}{\sin^2 \theta} \, d\theta = n\pi, \text{ } n \text{ being a positive integer.}$$

43. Show that if n is a positive integer, then

$$\int_0^{2\pi} \frac{\cos (n-1)x - \cos nx}{1 - \cos x} dx = 2\pi$$

and deduce that $\int_0^{2\pi} \left(\frac{\sin \frac{1}{2}nx}{\sin \frac{1}{2}x} \right)^2 dx = 2n\pi$.

44. If $I_{n, n} = \int_0^{\frac{\pi}{2}} \cos^n x \sin nx dx$, show that

$$I_{n, n} = \frac{1}{2^{m+1}} \left[2 + \frac{2^2}{2} + \frac{2^3}{3} + \dots + \frac{2^m}{m} \right].$$

45. Show that $\int_0^{\infty} e^{-ax} \sin^n x dx$

$$= \frac{n(n-1)(n-2)\dots 3 \cdot 2}{(a^2 + n^2)\{a^2 + (n-2)^2\}\dots(a^2 + 3^2)} \cdot \frac{1}{a^2 + 1}$$

if n is odd ;

$$= \frac{n(n-1)(n-2)\dots 2 \cdot 1}{\{a^2 + n^2\}\{a^2 + (n-2)^2\}\dots(a^2 + 2^2)} \cdot \frac{1}{a}$$

if n is even.

46. If $I_n = \int_0^{\frac{\pi}{2}} (a \cos \theta + b \sin \theta)^n d\theta$, then

$$nI_n = ab(a^{n-2} + b^{n-2}) + (n-1)(a^2 + b^2) I_{n-2}.$$

47. If $I_n = \int (a \cos^2 x + 2h \sin x \cos x + b \sin^2 x)^{-n} dx$,

prove that

$$4(n+1)(ab - h^2) I_{n+2} - 2(2n+1)(a+b) I_{n+1} + 4nI_n = 2 \frac{h(\cos^2 x - \sin^2 x) + (b-a) \sin x \cos x}{(a \cos^2 x + 2h \sin x \cos x + b \sin^2 x)^{n+1}}.$$

[Apply the alternative method of § 8'19]

48. Show that

$$(i) \int_{-1}^{+1} (1+x)^p (1-x)^q dx = 2^{p+q+1} \frac{\Gamma(p+1)\Gamma(q+1)}{\Gamma(p+q+2)}.$$

[$p > -1, q > -1$]

[Put $1+x=2y$]

$$(ii) \int_a^b (x-a)^m (b-x)^n dx = (b-a)^{m+n+1} \frac{\Gamma(m+1)\Gamma(n+1)}{\Gamma(m+n+2)}.$$

[$m > -1, n > -1$]

[Put $x-a=(b-a)y$]

49. Show that

$$\int_0^{\infty} e^{-x^2} x^{a^2} dx = \frac{1}{2} \Gamma\left(\frac{a+1}{2}\right). \quad [a > -1]$$

[Put $x^2=y$.]

50. Show that

$$\int_0^{\infty} e^{-x^4} x^2 dx \times \int_0^{\infty} e^{-x^4} dx = 8 \sqrt{2}.$$

[Put $x^4=z$]

51. Show that

$$\begin{aligned} B(m, n) B(m+n, l) &= B(n, l) B(n+l, m) \\ &= B(l, m) B(l+m, n). \end{aligned}$$

52. Show that

$$\Gamma\left(\frac{1}{8}\right) \Gamma\left(\frac{2}{8}\right) \cdots \Gamma\left(\frac{8}{8}\right) = \frac{3}{16} \pi^4.$$

[Combine 1st and last factors, 2nd and last but one, etc. and apply formula (vi), § 8.21.]

53. Show that

$$\int_0^1 \frac{dx}{(1-x^6)^{\frac{1}{6}}} = \frac{\pi}{3}. \quad [\text{Put } x^6 = z]$$

54. Show that the sum of the series

$$\frac{1}{n+1} + m \cdot \frac{1}{n+2} + \frac{m(m+1)}{2!} \cdot \frac{1}{n+3} + \frac{m(m+1)(m+2)}{3!} \cdot \frac{1}{n+4} + \dots \text{ to } \infty$$

$$= \frac{\Gamma(n+1)\Gamma(1-m)}{\Gamma(n-m+2)}, \text{ where } n > -1 \text{ and } m < 1.$$

$$\left[R. S. = B(n+1, 1-m) = \int_0^1 x^n(1-x)^{-m} dx \text{ etc.} \right]$$

55. Show that

$$\int_0^{\frac{1}{2}\pi} \frac{\sin^{2m-1}\theta \cos^{2n-1}\theta}{(a \sin^2\theta + b \cos^2\theta)^{m+n}} d\theta = \frac{1}{2} \cdot \frac{\Gamma(m)\Gamma(n)}{a^m b^n \Gamma(m+n)}.$$

[Apply Art. 8.21 (VIII)]

ANSWERS

1. $I_n = -\frac{x^n e^{-ax}}{a} + \frac{n}{a} I_{n-1},$

$$I_4 = -\frac{e^{-ax}}{a^5} [x^4 a^4 + 4x^3 a^3 + 12x^2 a^2 + 24xa + 24].$$

3. (i) $I_n = -\frac{\cot^{n-1}x}{n-1} - I_{n-2},$ (ii) $-\frac{\cot x \operatorname{cosec}^{n-2}x}{n-1} + \frac{n-2}{n-1} I_{n-2}.$

5. (i) $I_n = -\frac{\tanh^{n-1}\theta}{n-1} + I_{n-2},$ (ii) $I_n = \frac{\operatorname{sech}^{n-2}\theta \tanh \theta}{n-1} + \frac{n-2}{n-1} I_{n-2}.$

8. (i) $(x-3) \left[\frac{(x^2-6x+7)^5}{11} - \frac{20}{11.9} (x^2-6x+7)^4 + \frac{20.16}{11.9.7} (x^2-6x+7)^3 - \frac{20.16.12}{11.9.7.5} (x^2-6x+7)^2 + \frac{20.16.12.8}{11.9.7.5.3} (x^2-6x+7) - \frac{20.16.12.8.4}{11.9.7.5.3} \right].$

(ii) $\frac{x}{6(x^2+1)^3} + \frac{5x}{24(x^2+1)^2} + \frac{5x}{16(x^2+1)} + \frac{5}{16} \tan^{-1}x.$

(iii) $\frac{2x+1}{6(x^2+x+1)^2} + \frac{2x+1}{3(x^2+x+1)} + \frac{4}{3\sqrt{3}} \tan^{-1} \frac{2x+1}{\sqrt{3}}.$

(iv) $\frac{2x^2+5x+7}{6} \sqrt{x^2-2x+2} - \frac{1}{2} \sinh^{-1}(x-1).$

$$9. \frac{1}{2}x(a^2+x^2)^{\frac{3}{2}} + \frac{3}{8}a^2x(a^2+x^2)^{\frac{1}{2}} + \frac{3}{8}a^4 \log(x + \sqrt{a^2+x^2}).$$

$$12. (i) nI_n = -x^{n-1} \sqrt{2ax-x^2} + (2n-1)aI_{n-1}.$$

$$(ii) I_n = \frac{\sqrt{x^2-1}}{(n-1)x^{n-1}} + \frac{n-2}{n-1} I_{n-2}. \quad 13. \frac{7\pi a^5}{256}.$$

$$18. (i) \left. \begin{array}{l} \frac{n-1}{n} \cdot \frac{n-3}{n-2} \cdots \frac{2}{3} \text{ if } n \text{ is odd.} \\ \frac{n-1}{n} \cdot \frac{n-3}{n-2} \cdots \frac{1}{2} \cdot \frac{\pi}{2} \text{ if } n \text{ is even.} \end{array} \right\}$$

$$(ii) \left. \begin{array}{l} \frac{2n-3}{2n-2} \cdot \frac{2n-5}{2n-4} \cdots \frac{1}{2} \cdot \frac{\pi}{2}, \text{ if } n > 1 \\ \text{and } \frac{\pi}{2}, \text{ if } n = 1. \end{array} \right\}$$

$$22. (i) I_n = \frac{1}{2n-1} \cdot \frac{x}{(1+x^2)^{n-1}} \cdot \frac{x}{\sqrt{1+x^2}} + \frac{2n-2}{2n-1} I_{n-1}.$$

$$(ii) \frac{2n-2}{2n-1} \cdot \frac{2n-4}{2n-3} \cdots \frac{2}{3}.$$

$$28. (i) \frac{5\pi}{4096}. \quad (ii) \frac{8}{45}. \quad (iii) -\frac{\cos^4 x}{3 \sin^4 x} + \frac{4 \cos^2 x}{3 \sin x} + \frac{8 \sin x}{3}.$$

$$(iv) 2 \left[\frac{1}{3} \tan^{\frac{3}{2}} x + 2 \tan^{\frac{1}{2}} x - \frac{1}{3} \cot^{\frac{3}{2}} x \right].$$

$$30. I_{m,n} = \frac{-\cos^m x \cos nx}{m+n} + \frac{m}{m+n} I_{m-1, n-1} \quad \frac{1}{3}.$$

$$34. (n-1)(a^2-b^2) I_n = \frac{b \cos x}{(a+b \sin x)^{n-1}} + (2n-3)a I_{n-1} - (n-2) I_{n-2}.$$

$$35. (i) \frac{\pi}{2} \cdot (2 + \cos^2 a) \operatorname{cosec}^3 a.$$

$$(ii) \frac{1}{1-e^2} \frac{e \cos x}{1+e \sin x} + \frac{2}{(1-e^2)^{\frac{3}{2}}} \tan^{-1} \left\{ \frac{\tan \frac{1}{2} x + e}{\sqrt{1-e^2}} \right\}.$$

$$36. (i) \frac{(1+x^2)^{\frac{3}{2}}}{9 \cdot 11 \cdot 13} [99x^4 - 36x^2 + 8].$$

$$(ii) \frac{1}{3}(1+2x^3)^{\frac{1}{2}}(x^3-1). \quad (iii) 2\sqrt{3}.$$

$$37. I_m = -\frac{x^{m-1}(2ax-x^2)^{\frac{3}{2}}}{m+2} + \frac{(2m+1)a}{m+2} I_{m-1}.$$

CHAPTER IX
AREAS OF PLANE CURVES

[*Quadrature**]

9.1. Areas in Cartesian Co-ordinates.

Suppose we want to determine the area A_1 bounded by the curve $y = f(x)$, the x -axis, and two fixed ordinates $x = a$ and $x = b$. The function $f(x)$, is supposed to be single-valued, finite and continuous in the interval (a, b) .

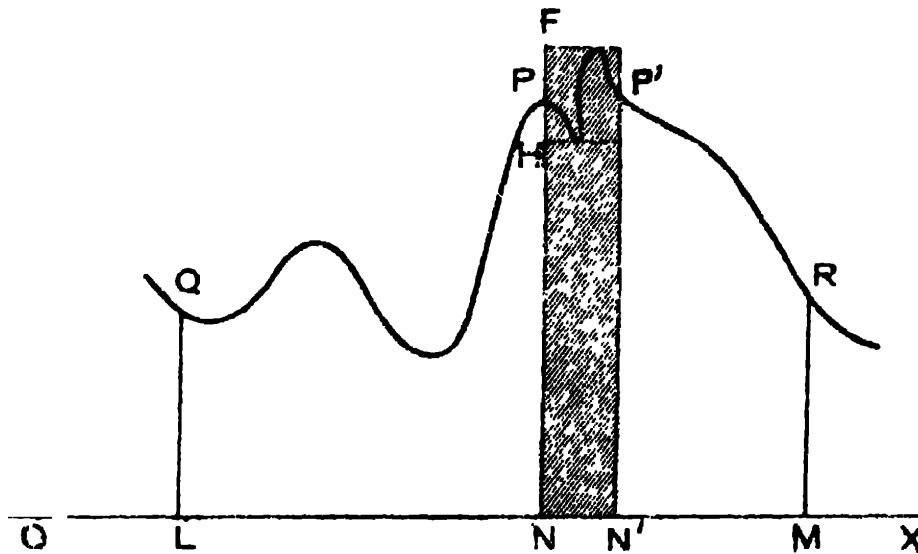

Consider the variable area $QLNP = A$ say, bounded by the curve $y = f(x)$, the x -axis, the fixed ordinate QL , where $OL = a$, and a variable ordinate PN where $ON = x$. Clearly,

*The process of finding the area, bounded by any defined contour line is called *Quadrature*, the term meaning 'the investigation of the size of a square which shall have the same area as that of the region under consideration'.

A has a definite value for each value of x and is thus a function of x . When x is increased by an amount Δx ($= NN'$), A assumes an increment ΔA = the area $PNN'P'$. Now, if $f(x_1)$ and $f(x_2)$ be the greatest and the least ordinates in the interval Δx ,

$$\text{such that, } x \leq x_1 \leq x + \Delta x, \quad x \leq x_2 \leq x + \Delta x,$$

clearly the area ΔA lies between the inscribed and circumscribed rectangles HN' and $I'N'$,

$$\text{i.e., } f(x_2) \Delta x < \Delta A < f(x_1) \Delta x.$$

$$\therefore f(x_2) < \frac{\Delta A}{\Delta x} < f(x_1). \quad \dots \quad (i)$$

Now, as Δx approaches zero, by the continuity of the function $f(x)$ at x , $f(x_1)$ and $f(x_2)$ both approach $f(x)$, and also $\frac{\Delta A}{\Delta x}$ tends to $\frac{dA}{dx}$. Hence, as the relation (i) is always true, we get in the limit

$$\frac{dA}{dx} = f(x).$$

\therefore by definition, $A = \int f(x) dx + C \equiv F(x) + C$ where C is an arbitrary constant, and $F(x)$ an indefinite integral of $f(x)$. Now, when $x = a$, PN coincides with QL , and the area becomes zero. Also, when $x = b$, the area A becomes the required area A_1 .

$$\therefore 0 = F(a) + C \text{ and } A_1 = F(b) + C.$$

$$\therefore A_1 = F(b) - F(a) = \int_a^b f(x) dx.$$

The definite integral

$$\int_a^b f(x) dx, \text{ i.e., } \int_a^b y dx$$

therefore represents the area bounded by the curve $y=f(x)$, the x -axis, and the two fixed ordinates $x=a$ and $x=b$.

Note. An alternative method of proof of the above result, depending on the definition of a definite integral as a summation, has been given in Art. 6'3.

Cor. 1. In the same way, it can be shown that the area bounded by any curve, two given abscissæ ($y=c$, $y=d$), and the y -axis is

$$\int_c^d x dy.$$

Cor. 2. If the axes be oblique, ω being the angle between them, the corresponding formulæ for the areas would be

$$\sin \omega \int_a^b y dx \text{ and } \sin \omega \int_c^d x dy \text{ respectively.}$$

Illustrative Examples.

Ex. 1. Find the area of the quadrant of the ellipse $\frac{x^2}{a^2} + \frac{y^2}{b^2} = 1$ between the major and minor axes.

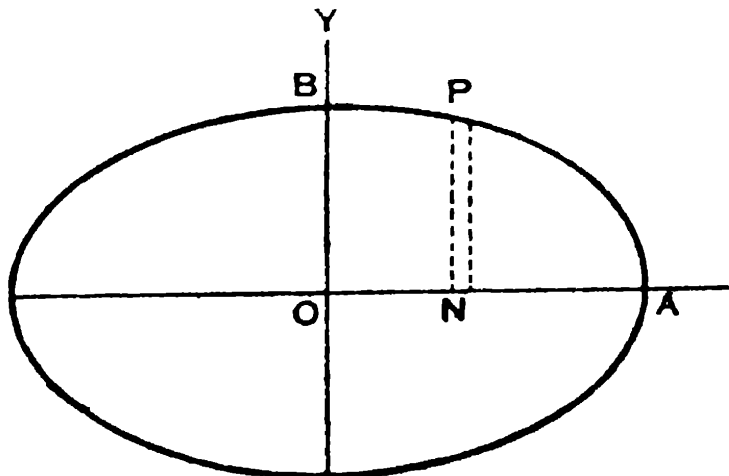

Clearly the area being bounded by the curve, the x -axis and the ordinates $x=0$ and $x=a$, the required area = $\int_0^a y \, dx$

$$= \int_0^a \frac{b}{a} \sqrt{a^2 - x^2} \, dx, \left[\because \frac{x^2}{a^2} + \frac{y^2}{b^2} = 1 \text{ for the curve} \right]$$

$$= \frac{b}{a} \int_0^{\frac{\pi}{2}} a \cos \theta \cdot a \cos \theta \, d\theta \quad (\text{putting } x = a \sin \theta)$$

$$= \frac{ab}{2} \int_0^{\frac{\pi}{2}} (1 + \cos 2\theta) \, d\theta = \frac{ab}{2} \left\{ \theta + \frac{\sin 2\theta}{2} \right\}_0^{\frac{\pi}{2}}$$

$$= \frac{ab}{2} \cdot \frac{\pi}{2} = \frac{1}{4} \pi ab.$$

Cor. 1. The area of the whole ellipse is clearly four times the above, *i.e.*, $=\pi ab$.

Cor. 2. Putting $b=a$ and proceeding exactly as before, the area of a quadrant of the circle, $x^2 + y^2 = a^2$, is $\frac{1}{4}\pi a^2$, and the area of the whole circle $=\pi a^2$.

Ex. 2. Determine the area bounded by the parabola $y^2 = 4ax$ and any double ordinate of it, say $x = x_1$.

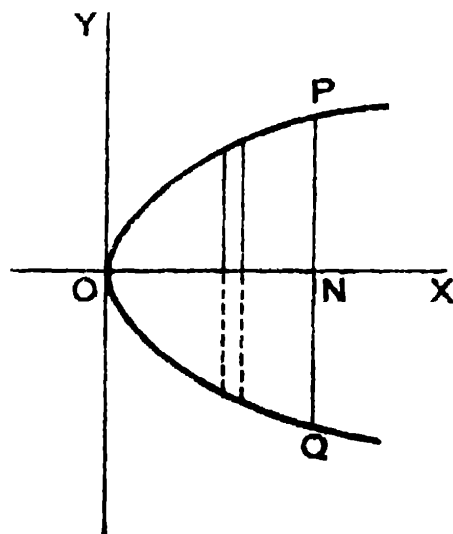

The area OPN is bounded by the curve $y^2 = 4ax$, the x -axis, and the two ordinates $x=0$ and $x=x_1$.

$$\therefore \text{area } OPN = \int_0^{x_1} y \, dx = \int_0^{x_1} \sqrt{4ax} \, dx$$

[The *positive* value of y is taken since we are considering the positive side of the y -axis]

$$\begin{aligned} &= \sqrt{4a} \left[\frac{2}{3} x^{\frac{3}{2}} \right]_0^{x_1} \\ &= \sqrt{4a} \cdot \frac{2}{3} x_1^{\frac{3}{2}} = \frac{2}{3} x_1 y_1 \\ &\quad (\text{where } y_1 = PN = \sqrt{4ax_1}). \end{aligned}$$

The parabola being symmetrical about the x -axis, the required area POQ ,

$$\begin{aligned} &= 2 \cdot \frac{2}{3} x_1 y_1 = \frac{4}{3} x_1 y_1 \\ &= \frac{2}{3} \text{ the area of the rectangle contained by } PQ \text{ and } ON, \\ \text{i.e., } &= \frac{2}{3} \text{ the area of the circumscribed rectangle.} \end{aligned}$$

Cor. The area bounded by the parabola and its latus rectum $= \frac{2}{3} a^2$.

Ex. 3. Find the whole area of the cycloid $x = a(\theta + \sin \theta)$, $y = a(1 - \cos \theta)$, bounded by its base.

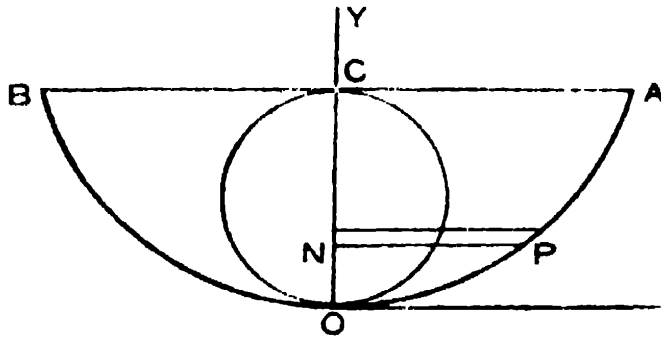

The area of half the cycloid, *viz.*, area ΔOC , is evidently bounded by the curve, the y -axis and the abscissæ $y=0$ and $y=2a$. Hence, this area is given by

$$\begin{aligned} &\int_0^{2a} x \, dy \\ &= \int_0^{\pi} a(\theta + \sin \theta) \cdot a \sin \theta \, d\theta \quad \left[\begin{array}{l} \because y = a(1 - \cos \theta) \\ x = a(\theta + \sin \theta) \end{array} \right] \end{aligned}$$

$$= a^2 \left[-\theta \cos \theta + \sin \theta + \frac{1}{2}(\theta - \frac{1}{2} \sin 2\theta) \right]_0^\pi = \frac{3}{2} \pi a^2.$$

Hence, the whole area of the cycloid is $3\pi a^2$.

Note. It should be noted here that if AM be drawn perpendicular from A on OX , the expression $\int_0^{OM} y \, dx$ represents the area OAM , and not the area OAC .

Ex. 4. Find the area of the loop of the curve

$$xy^2 + (x+a)^2(x+2a) = 0.$$

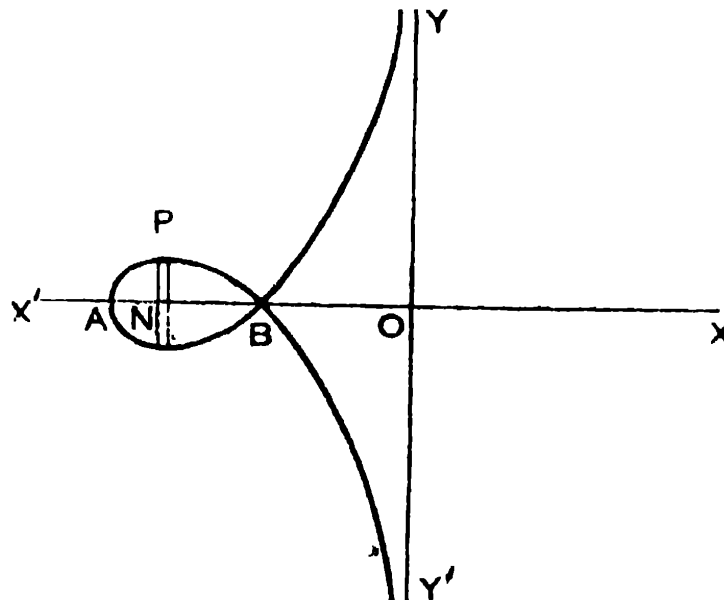

Here let us first of all trace the curve. The equation can be put in the form $y^2 = -\frac{(x+a)^2(x+2a)}{x}$. We notice that $y=0$ at the points B and A where $x=-a$ and $x=-2a$, and $y \rightarrow \pm \infty$ when $x \rightarrow 0$. For positive values of x , as also for negative values of x less than $-2a$, y^2 is negative and so y is imaginary. There is thus no part of the curve beyond O to the right, or beyond A ($x=-2a$) to the left. From A to B , for each value of x , y has two equal and opposite finite values and a loop is thus formed within this range, symmetrical about the x -axis. From B to O , each value of x gives two equal and opposite values of y which gradually increase in magnitude to ∞ as x approaches O . The curve therefore is as shown in the figure.

The required area of the loop now

$$= 2 \cdot \text{area } APB$$

$$= 2 \cdot \int_{-2a}^{-a} y \, dx = 2 \int_{-2a}^{-a} \sqrt{\frac{-(x+a)^2(x+2a)}{x}} \, dx$$

and substituting z for $x+2a$, this reduces to

$$2 \int_0^a (a-z) \cdot \sqrt{\frac{z}{2a-z}} \, dz$$

$$= 2 \int_0^{\frac{\pi}{2}} a \cos \theta \frac{\sin \frac{1}{2}\theta}{\cos \frac{1}{2}\theta} \cdot 2a \sin \theta \cos \theta \, d\theta$$

$$\left[\text{putting } z = 2a \sin^2 \frac{\theta}{2} \right]$$

$$= 2a^2 \int_0^{\frac{\pi}{2}} \cos \theta (1 - \cos \theta) \, d\theta = 2a^2 \left(1 - \frac{\pi}{4} \right)$$

$$= \frac{1}{2}a^2 (4 - \pi).$$

9.2. Area between two given curves and two given ordinates.

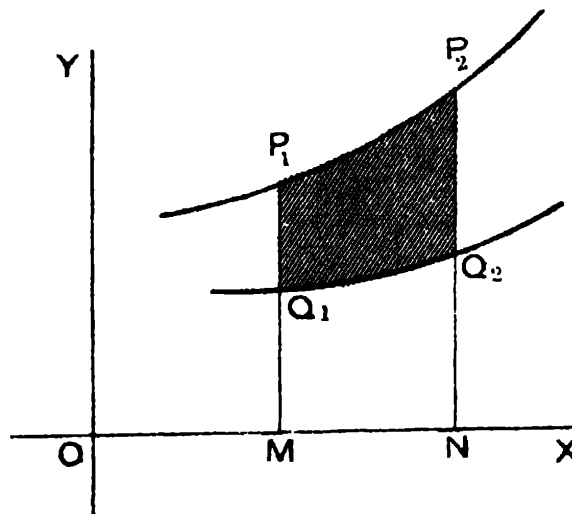

Let the area required be bounded by two given curves $y=f_1(x)$ and $y=f_2(x)$ and two given ordinates $x=a$ and $x=b$, indicated by $Q_1Q_2P_2P_1Q_1$ in the above figure, where $OM=a$ and $ON=b$.

Clearly,

$$\begin{aligned} \text{area } Q_1Q_2P_2P_1Q_1 &= \text{area } P_1MNP_2 - \text{area } Q_1MNQ_2 \\ &= \int_a^b f_1(x) dx - \int_a^b f_2(x) dx \\ &= \int_a^b \{f_1(x) - f_2(x)\} dx \\ &= \int_a^b (y_1 - y_2) dx \end{aligned}$$

where y_1 and y_2 denote the ordinates of the two curves P_1P_2 and Q_1Q_2 corresponding to the same abscissa x .

Illustrative Examples.

Ex. 1. Find the area above the x -axis, included between the parabola $y^2 = ax$ and the circle $x^2 + y^2 = 2ax$.

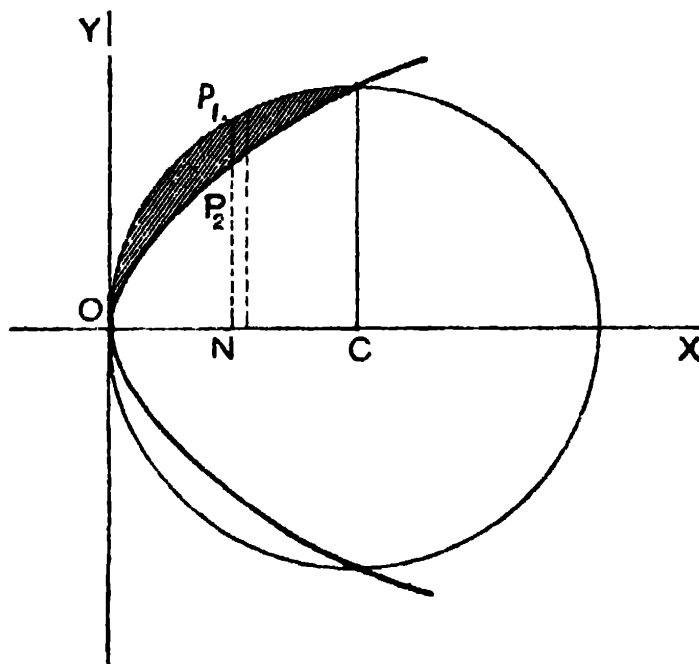

* The abscissæ of the common points of the curves $y^2 = ax$ and $x^2 + y^2 = 2ax$ are given by $x^2 + ax = 2ax$, i.e., $x = 0$ and $x = a$.

We are thus to find out the area between the curves and the ordinates $x = 0$ and $x = a$ above the x -axis (i.e., for positive values only of the ordinates).

The required area is therefore

$$\int_0^a (y_1 - y_2) dx \text{ [where } y_1^2 = 2ax - x^2 \text{ and } y_2^2 = ax \text{]}$$

$$= \int_0^a (\sqrt{2ax - x^2} - \sqrt{ax}) dx.$$

Now, putting $x = 2a \sin^2 \theta$,

$$\int_0^a \sqrt{2ax - x^2} dx = \int_0^{\frac{\pi}{4}} 2a \sin \theta \cos \theta \cdot 4a \sin \theta \cos \theta d\theta$$

$$= a^2 \int_0^{\frac{\pi}{4}} (1 - \cos 4\theta) d\theta = a^2 \left[\theta - \frac{\sin 4\theta}{4} \right]_0^{\frac{\pi}{4}} = \frac{\pi}{4} a^2.$$

Also, $\int_0^a \sqrt{ax} dx = \sqrt{a} \left[\frac{2}{3} x^{\frac{3}{2}} \right]_0^a = \frac{2}{3} a^{\frac{3}{2}}.$

Hence, the required area is

$$\frac{\pi}{4} a^2 - \frac{2}{3} a^{\frac{3}{2}} = a^2 \left(\frac{\pi}{4} - \frac{2}{3} \right).$$

Ex. 2. Find by integration, the area of the ellipse

$$ax^2 + 2hxy + by^2 = 1.$$

[C. P. 1926]

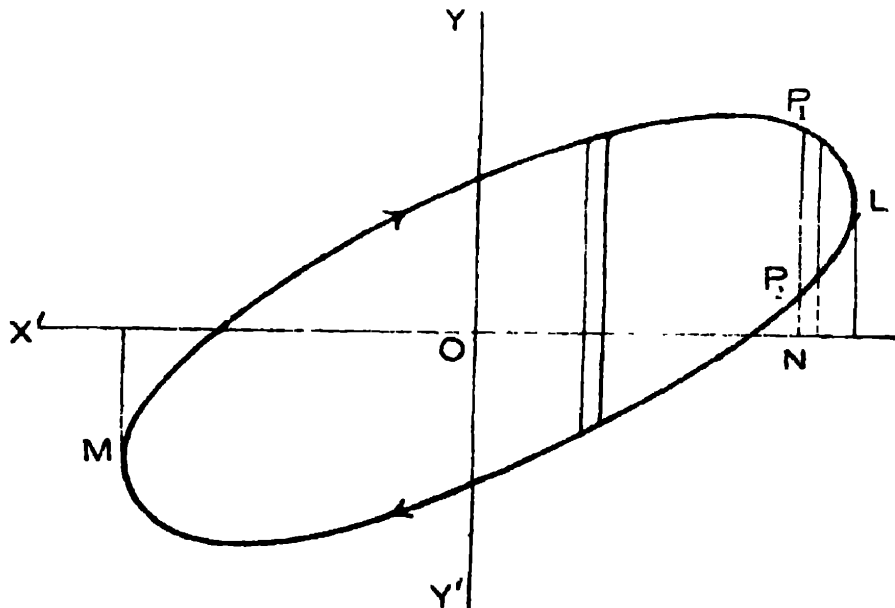

The equation can be put in the form

$$by^2 + 2hxy + (ax^2 - 1) = 0.$$

If y_1, y_2 be the values of y corresponding to any values of x , we have

$$y_1 - y_2 = \frac{2}{b} \sqrt{h^2 x^2 - b(ax^2 - 1)} = \frac{2}{b} \sqrt{b - (ab - h^2)x^2},$$

$ab - h^2$ being positive here, since the conic is an ellipse.

The extreme values of x , where the ordinates touch the ellipse, are given by

$$y_1 - y_2 = 0, \text{ i.e., } x = \pm \sqrt{\frac{b}{ab - h^2}}.$$

The required area can be treated as bounded by two curves, MP_1L , LP_2M respectively, both satisfying the given equation, but one having a single value y_1 for y corresponding to any value of x , and the other also having a single value y_2 for the same value of x .

Hence, the area required

$$= \int_{-\sqrt{\frac{b}{ab-h^2}}}^{+\sqrt{\frac{b}{ab-h^2}}} (y_1 - y_2) dx = \frac{2}{b} \int_{-\sqrt{\frac{b}{ab-h^2}}}^{+\sqrt{\frac{b}{ab-h^2}}} \sqrt{b - (ab - h^2)x^2} dx$$

and putting $\sqrt{ab - h^2} x = \sqrt{b} \sin \theta$, this becomes

$$= \frac{2}{\sqrt{ab - h^2}} \int_{-\frac{\pi}{2}}^{\frac{\pi}{2}} \cos^2 \theta d\theta = \frac{\pi}{\sqrt{ab - h^2}}.$$

Note. The area of the above ellipse can also be obtained as follows :

Assuming the equation of the ellipse referred to its major and minor axes as axes of co ordinates to be $\frac{x^2}{a^2} + \frac{y^2}{\beta^2} = 1$, by the theory of invariants as given in Conic Sections, we know that $\frac{1}{a^2} \cdot \frac{1}{\beta^2} = ab - h^2$.

Now (from Ex. 1, Cor. Art. 9'1) the area of the ellipse is

$$\pi a \beta = \frac{\pi}{\sqrt{ab - h^2}}.$$

Ex. 3. Find the area between the curve $y^2 = \frac{(a-x)^3}{a+x}$ and the asymptote.

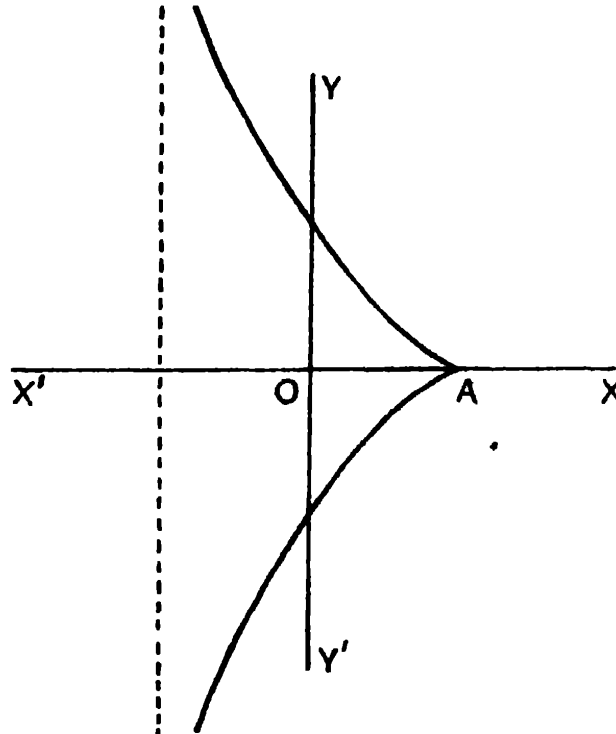

To trace the curve, we notice that y is imaginary for values of x greater than a or less than $-a$. At $x=a$, $y=0$, and for a to $-a$, for each value of x , y has two equal and opposite values, tending to $\pm\infty$ as x approaches $-a$. At $x=a$, the x -axis touches both the branches. The figure is therefore as shown above, symmetrical about the x -axis.

The required area between the curve and its asymptote is therefore

$$2 \int_{-a}^a y \, dx = 2 \int_{-a}^a \sqrt{\frac{(a-x)^3}{a+x}} \, dx$$

and substituting z for $a+x$ this reduces to

$$2 \int_0^{2a} (2a-z) \sqrt{\frac{2a-z}{z}} \, dz$$

$$= 2 \int_0^{\frac{1}{2}\pi} 2a \cos^2 \theta \frac{\cos \theta}{\sin \theta} \cdot 4a \sin \theta \cos \theta \, d\theta$$

[where $z = 2a \sin^2 \theta$]

$$= 16a^3 \int_0^{\frac{1}{2}\pi} \cos^4 \theta \, d\theta = 16a^3 \frac{1.3 \cdot \pi}{2.4 \cdot 2} = 3\pi a^2.$$

9.3. Areas in Polar co-ordinates.

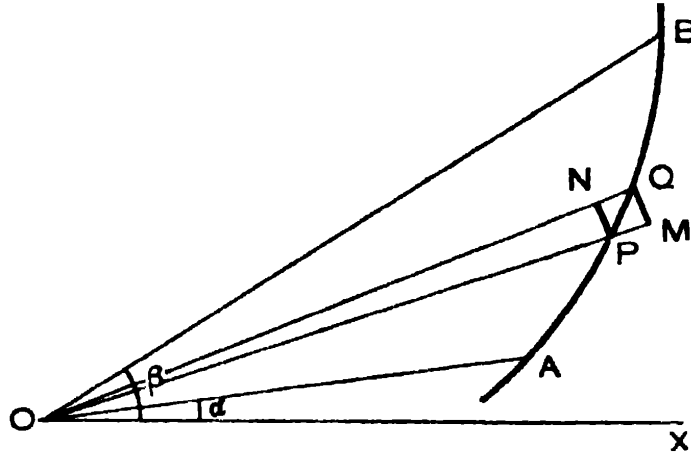

Let $r = f(\theta)$ be a curve APB , where $f(\theta)$ is supposed to be a finite, continuous and single-valued function in the interval $\alpha < \theta < \beta$. The area bounded by the curve, and the radii vectors $\theta = \alpha$ and $\theta = \beta$ is given by the definite integral

$$\frac{1}{2} \int_{\alpha}^{\beta} r^2 d\theta, \quad \text{i.e.,} \quad \frac{1}{2} \int_{\alpha}^{\beta} \{f(\theta)\}^2 d\theta.$$

Let A denote the area POA , bounded by the curve, the given radius vector OA , i.e., $\theta = \alpha$, and the variable radius vector OP at vectorial angle θ , $\alpha < \theta < \beta$. Then for each value of θ , A has a definite value and so A is a function of θ . If Q be the neighbouring point $r + \Delta r$, $\theta + \Delta\theta$ on the curve, we have

$$\begin{aligned} \Delta A &= \text{the infinitesimal change in } A \text{ due to a change } \Delta\theta \text{ in } \theta \\ &= \text{the elementary area } POQ \end{aligned}$$

and this clearly lies between the circular sectorial areas OPN and OQM , where PN and QM are arcs of circles with centre O .

Thus, $\frac{1}{2}r^2 \Delta\theta < \Delta A < \frac{1}{2}(r + \Delta r)^2 \Delta\theta$,

$$i.e., \quad \frac{1}{2}\{f(\theta)\}^2 < \frac{\Delta A}{\Delta\theta} < \frac{1}{2}\{f(\theta + \Delta\theta)\}^2.$$

Now, proceeding to the limit, and remembering that $f(\theta)$ being continuous, $f(\theta + \Delta\theta) \rightarrow f(\theta)$ as $\Delta\theta \rightarrow 0$, we get

$$\frac{dA}{d\theta} = \frac{1}{2}\{f(\theta)\}^2, \quad i.e., \quad \frac{1}{2}r^2.$$

Thus, $A = \frac{1}{2} \int r^2 d\theta + C = F(\theta) + C$ say.

Now, taking P coincident with A and B respectively and denoting the required area AOB by A_1 , we get

$$0 = F(a) + C \quad \text{and} \quad A_1 = F(\beta) + C,$$

$$\text{whence } A_1 = F(\beta) - F(a) = \frac{1}{2} \int_a^\beta r^2 d\theta.$$

Note 1. The curve APB is here assumed as concave towards O . A similar proof with corresponding modifications holds even if the curve be convex, or partly concave and partly convex or wavy, in fact of any form.

Note 2. As in the case of area in Cartesian co-ordinates, the above result can also be deduced directly from the definition of a definite integral as a summation. [See *Appendix*]

Cor. The area bounded by the two curves $r_1 = f_1(\theta)$ and $r_2 = f_2(\theta)$ and two given radii vectors $\theta = a$ and $\theta = \beta$ is

$$\frac{1}{2} \int_a^\beta (r_2^2 - r_1^2) d\theta.$$

Illustrative Examples.

Ex. 1. Find the area bounded by the cardioid $r = a(1 - \cos \theta)$.

The curve is symmetrical about the initial line, since replacing θ by $-\theta$, r does not alter. Beginning from $\theta = 0$ and gradually

increasing θ to π , the corresponding values of r are noticed, and the curve is easily traced as below.

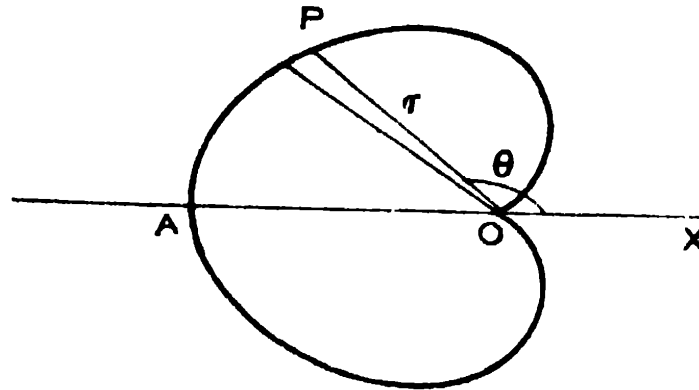

Now, the required area is evidently, from the above article,

$$2 \cdot \frac{1}{2} \int_0^{\pi} r^2 d\theta = a^2 \int_0^{\pi} (1 - \cos \theta)^2 d\theta = a^2 \cdot \frac{3}{2} \pi = \frac{3}{2} \pi a^2.$$

Note. It should be noted that the area bounded by the cardioid whose equation is $r = a(1 + \cos \theta)$ is also $\frac{3}{2} \pi a^2$.

Ex. 2. Find the area of a loop of the curve $r = a \cos 2\theta$.

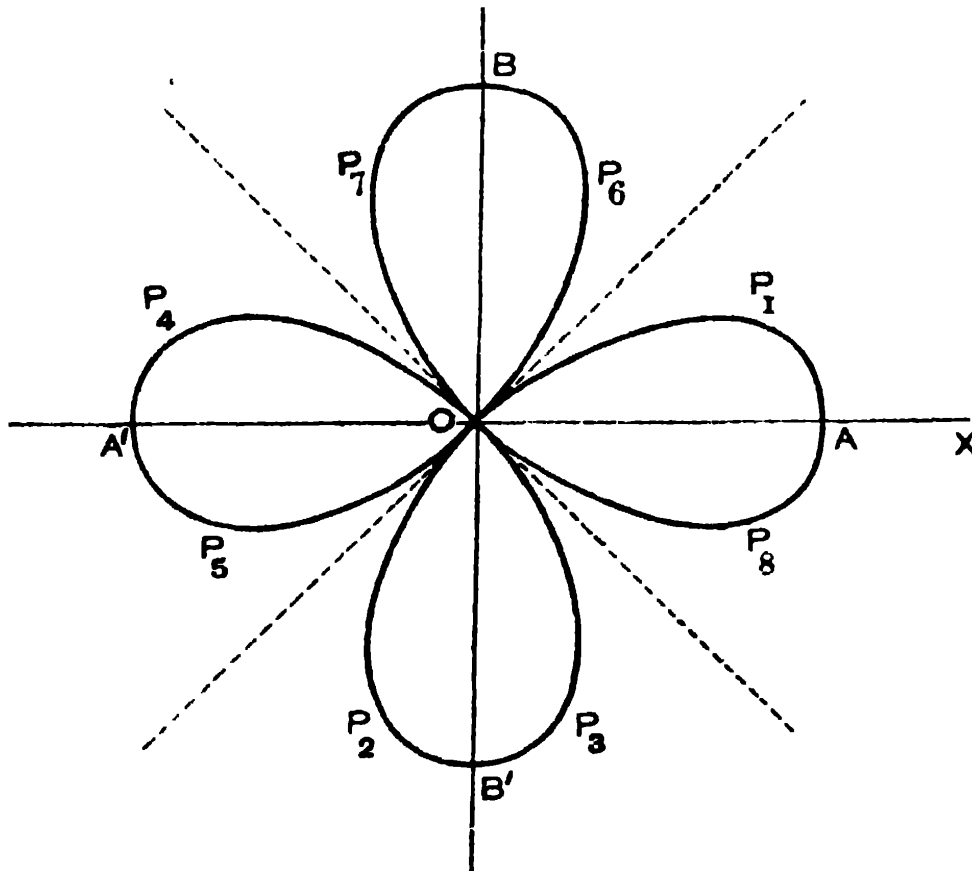

In tracing the curve, we notice that as θ increases from 0 to $\frac{1}{4}\pi$, r diminishes from a to 0, the portion AP_1O being thus traced. As θ increases from $\frac{1}{4}\pi$ to $\frac{3}{4}\pi$, r is negative throughout, and the corresponding portion of the curve which is traced is $OP_2B'P_3O$. Then as θ increases from $\frac{3}{4}\pi$ to $\frac{5}{4}\pi$, r remains positive and the portion $OP_4A'P_5O$ of the curve is traced. As θ increases from $\frac{5}{4}\pi$ to $\frac{7}{4}\pi$, r is again negative and we get the portion OP_6BP_7O of the curve. Finally, when θ increases from $\frac{7}{4}\pi$ to 2π , r is positive, and the portion OP_8AP_1O of the curve is described. The curve thus consists of four equal loops as shown in the figure.

It is now clear from the figure that area of one loop

$$\begin{aligned} &= 2 \cdot \text{area } AP_1O \\ &= 2 \cdot \frac{1}{2} \int_0^{\frac{1}{4}\pi} r^2 d\theta = a^2 \int_0^{\frac{1}{4}\pi} \cos^2 2\theta d\theta = \frac{1}{8}\pi a^2. \end{aligned}$$

Cor. Hence, the entire area of the curve *i.e.*, the sum of the areas of the 4 loops $= \frac{1}{2}\pi a^2$.

Note. All curves of the type $r = a \sin n\theta$, or $r = a \cos n\theta$ may be similarly traced, by dividing each quadrant into n equal parts, and increasing θ successively through each division. If r be found positive, the traced portion of the curve will be in the same division; if r be negative, the traced part will be in the diametrically opposite division. Any way, when the curve is completely traced, it will be found to consist of n equal loops if n be odd, and $2n$ equal loops if n be even.

Ex. 3. (i) Find the area of the loop of the folium of Descartes

$$x^3 + y^3 = 3axy.$$

(ii) Find also the area included between the folium and its asymptote and show that it is equal to the area of the loop.

(i) Transforming to corresponding polar co-ordinates by putting $x = r \cos \theta$, $y = r \sin \theta$, the polar equation to the curve becomes

$$r = \frac{3a \cos \theta \sin \theta}{\cos^3 \theta + \sin^3 \theta} \quad \dots (1)$$

As θ increases from 0 to $\frac{1}{2}\pi$, r at first increases from 0 to $\frac{3a}{\sqrt{2}}$,

reaching the maximum at $\theta = \frac{1}{4}\pi$, and then diminishes to 0 again, thus forming a loop in the first quadrant.

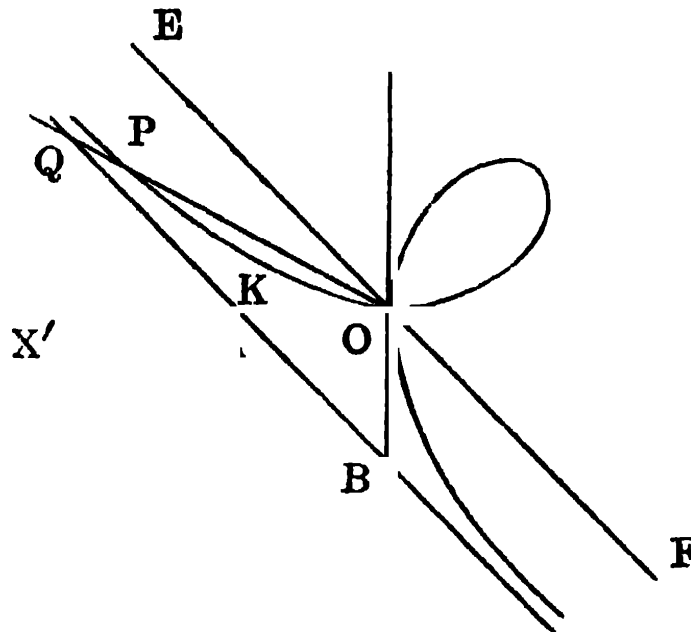

The required area of the loop is

$$\begin{aligned}
 &= \frac{1}{2} \int_0^{\frac{1}{2}\pi} r^2 d\theta = \frac{9a^2}{2} \int_0^{\frac{1}{2}\pi} \frac{\sin^2\theta \cos^2\theta}{(\sin^3\theta + \cos^3\theta)^2} d\theta \\
 &= \frac{9a^2}{2} \int_0^{\infty} \frac{t^3 dt}{(1+t^3)^2} \quad [\text{putting } t = \tan \theta] \\
 &= \frac{9a}{2} \lim_{\epsilon \rightarrow \infty} \int_0^{\epsilon} \frac{t^3 dt}{(1+t^3)^2} = \frac{3a^2}{2} \lim_{\epsilon \rightarrow \infty} \left[-\frac{1}{1+\epsilon^3} + 1 \right] \\
 &= \frac{3}{2}a^2.
 \end{aligned}$$

(ii) The equation of the asymptote of the folium is

$$x + y + a = 0. \quad \dots (2)$$

Its polar equation is

$$r = \frac{-a}{\sin \theta + \cos \theta}. \quad \dots (3)$$

Now, $r \rightarrow \infty$, if $(\sin \theta + \cos \theta) \rightarrow 0$ i.e., if $\tan \theta \rightarrow -1$
i.e., if $\theta \rightarrow \frac{3}{4}\pi$.

\therefore the direction of the asymptote is $\theta \rightarrow \frac{3}{4}\pi$.

The asymptote intersects the two axes at A and B , where

$$OA = a \text{ and } OB = a, \text{ i.e., } OA = OB.$$

Hence, the area of $\triangle OAB = \frac{1}{2}a^2$ (4)

Area between the folium and its asymptote = triangular area OAB + the limiting value of twice the area between the curve and the asymptote in the second quadrant (from symmetry)

$$\begin{aligned} &= \frac{1}{2}a^2 + \text{limiting value of twice the curvilinear area } OKPQAO \\ &= \frac{1}{2}a^2 + 2\sigma \text{ (say)}. \end{aligned} \quad \dots (5)$$

Draw a radius vector OPQ making an angle θ with the x -axis, such that $\frac{3}{4}\pi < \theta < \pi$. Suppose it cuts the curve and the asymptote at P and Q respectively.

Let us denote the curvilinear area $OKPQAO$ by S ,

the triangular area $OQAO$ by S_1 ,

and the curvilinear area $OKPO$ by S_2 .

$$\therefore S = S_1 - S_2.$$

$$\therefore \sigma = \lim_{\theta \rightarrow \frac{3}{4}\pi} S = \lim_{\theta \rightarrow \frac{3}{4}\pi} (S_1 - S_2).$$

Now, applying the formula for area in polar co-ordinates i.e., $\frac{1}{2} \int r^2 d\theta$ and using equations (1) and (3), we get

$$\begin{aligned} S &= \frac{1}{2} \left[\int_{\theta}^{\pi} \frac{a^2 d\theta}{(\sin \theta + \cos \theta)^2} - \int_{\theta}^{\pi} \frac{9a^2 \sin^2 \theta \cos^2 \theta}{(\sin^3 \theta + \cos^3 \theta)^2} d\theta \right] \\ &= \frac{1}{2}a^2 (I_1 - I_2) \text{ say.} \end{aligned}$$

Now, $\int \frac{d\theta}{(\sin \theta + \cos \theta)^2} = \int \frac{\sec^2 \theta d\theta}{(1 + \tan \theta)^2}$

[on multiplying numerator and denominator by $\sec^2 \theta$]

$$= \int \frac{dt}{t^2} \quad [\text{putting } t = 1 + \tan \theta]$$

$$\frac{1}{t} = -\frac{1}{1 + \tan \theta}$$

$$\therefore I_1 = - \left[\frac{1}{1 + \tan \theta} \right]_{\theta}^{\pi} = \frac{1}{1 + \tan \theta} - 1.$$

Again,
$$\int \frac{\sin^2 \theta \cos^2 \theta d\theta}{(\sin^3 \theta + \cos^3 \theta)^2} = \int \frac{\tan^2 \theta \sec^2 \theta}{(1 + \tan^3 \theta)^2} d\theta$$
 (on multiplying numerator and denominator by $\sec^2 \theta$)

$$= \int \frac{dt}{3t^2}, \text{ putting } 1 + \tan^3 \theta = t$$

$$= -\frac{1}{3} \cdot \frac{1}{t} = -\frac{1}{3} \cdot \frac{1}{(1 + \tan^3 \theta)}$$

$$\therefore I_2 = 0 - \frac{1}{3} \cdot \left[\frac{1}{1 + \tan^3 \theta} \right]_{\theta}^{\pi} = \frac{3}{1 + \tan^3 \theta} - 3.$$

$$\begin{aligned} \therefore S &= \frac{1}{2} a^2 \left[2 + \frac{1}{1 + \tan \theta} - \frac{3}{1 + \tan^3 \theta} \right] \\ &= \frac{1}{2} a^2 \left[2 + \frac{\tan^2 \theta - \tan \theta - 2}{1 + \tan^3 \theta} \right] \\ &= \frac{1}{2} a^2 \left[2 + \frac{(\tan \theta + 1)(\tan \theta - 2)}{(1 + \tan \theta)(1 - \tan \theta + \tan^2 \theta)} \right] \\ &= \frac{1}{2} a^2 \left[2 + \frac{\tan \theta - 2}{1 - \tan \theta + \tan^2 \theta} \right]. \end{aligned}$$

Now, $\sigma = \lim_{\theta \rightarrow \frac{3\pi}{4}} Lt \quad S = \frac{1}{2} a^2.$

$$\therefore \text{required area} = \frac{1}{2} a^2 + 2\sigma = \frac{3}{2} a^2$$

= area of the loop.

Ex. 4. Find the area between the cuspid $r = \frac{a \sin^2 \theta}{\cos \theta}$ and its asymptote.

The curve may be traced either from its polar equation, or by converting it to Cartesian form, and the figure will be as shown below. The asymptote is easily found to be the line $x = a$, or in polar

co-ordinates $r \cos \theta = a$. Now, let OPQ be any radius vector at an angle θ to the x -axis, intersecting the curve and its asymptote at P and Q respectively.

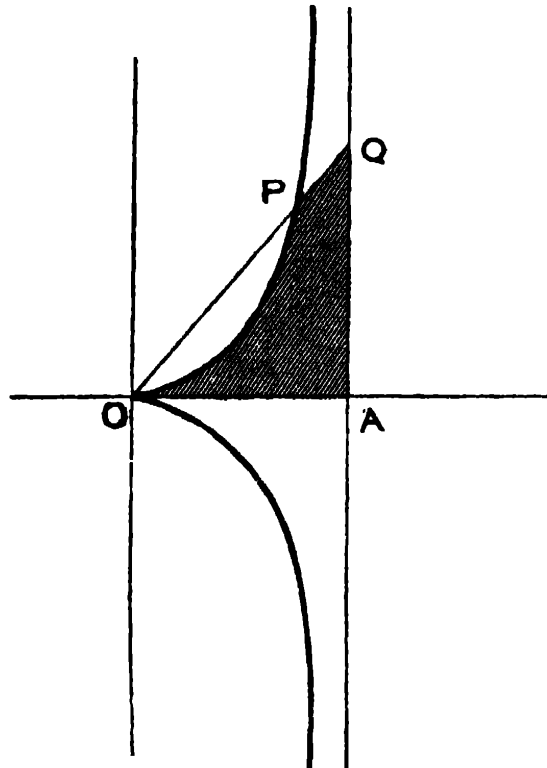

$$\begin{aligned} \text{Area } OAQPO &= \frac{1}{2} \int_0^{\theta} (r_1^2 - r_2^2) d\theta && [\text{ where } r_1 = OQ \\ & && r_2 = OP] \\ &= \frac{1}{2} \int_0^{\theta} \left(\frac{a^2}{\cos^2 \theta} - a^2 \frac{\sin^4 \theta}{\cos^2 \theta} \right) d\theta \\ &= \frac{a^2}{2} \int_0^{\theta} (1 + \sin^2 \theta) d\theta \\ &= \frac{a^2}{2} \left\{ \frac{3}{2} \theta - \frac{\sin 2\theta}{4} \right\} \end{aligned}$$

Now, the required area between the curve and the asymptote is clearly (there being symmetry about the x -axis, and since the direction of the asymptote is given by $\theta = \frac{1}{2}\pi$),

$$\lim_{\theta \rightarrow \frac{1}{2}\pi} \left[2 \cdot \frac{a^2}{2} \left(\frac{3}{2} \theta - \frac{\sin 2\theta}{4} \right) \right] = a^2 \left(\frac{3}{2} \cdot \frac{1}{2}\pi \right) = \frac{3}{4} \pi a^2.$$

Ex. 5. Find the area common to the Cardioid $r = a(1 + \cos \theta)$ and the circle $r = \frac{3}{2}a$, and also the area of the remainder of the Cardioid.

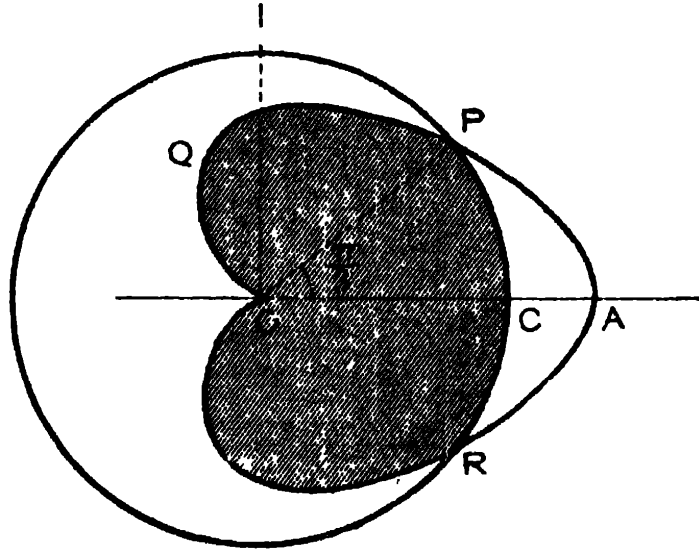

At the common point P of the two curves, we have

$$\frac{3}{2}a = 1 + \cos \theta. \quad \therefore \cos \theta = \frac{1}{2}, \text{ or, } \theta = \frac{1}{3}\pi.$$

The reqd. area is easily seen to be

$$\begin{aligned} & 2 \{ \text{area } OCP + \text{area } PQO \} \\ &= 2 \left\{ \frac{1}{2} \int_0^{\frac{1}{3}\pi} \left(\frac{3}{2}a\right)^2 d\theta + \frac{1}{2} \int_{\frac{1}{3}\pi}^{\pi} a^2 (1 + \cos \theta)^2 d\theta \right\} \\ &= \frac{9}{4}a^2 \cdot \frac{1}{3}\pi + a^2 \left\{ \frac{3}{2}(\pi - \frac{1}{3}\pi) + 2(\sin \pi - \sin \frac{1}{3}\pi) + \frac{1}{4}(\sin 2\pi - \sin \frac{2}{3}\pi) \right\} \\ &= \left(\frac{7}{4}\pi - \frac{9\sqrt{3}}{8} \right) a^2. \end{aligned}$$

Again, the area of the remainder of the Cardioid, *i.e.*, $APCR$

$$\begin{aligned} &= 2 \cdot \text{area } APC = 2 \cdot \frac{1}{2} \int_0^{\frac{1}{3}\pi} (r_1^2 - r_2^2) d\theta \\ &= \int_0^{\frac{1}{3}\pi} \{ a^2 (1 + \cos \theta)^2 - \frac{9}{4}a^2 \} d\theta \\ &= a^2 \int_0^{\frac{1}{3}\pi} (2 \cos \theta + \frac{1}{2} \cos 2\theta - \frac{3}{4}) d\theta \\ &= a^2 \left\{ 2 \cdot \frac{\sqrt{3}}{2} + \frac{1}{4} \cdot \frac{\sqrt{3}}{2} - \frac{3}{4} \cdot \frac{1}{3}\pi \right\} \\ &= a^2 \left\{ \frac{9\sqrt{3}}{8} - \frac{\pi}{4} \right\}. \end{aligned}$$

Note. The whole area of the Cardioid is evidently the sum of these two, *i.e.*, $= \frac{3}{2}\pi a^2$. [See *Ex. 1* above.]

9.4. The Sign of an area.

In the expression $\int_a^b y \, dx$ for an area, we tacitly assume that the ordinate y is positive throughout the range (a, b) , and that x increases from a to b , *i.e.*, $b > a$. In this case the area calculated by the above formula will be positive. If however y be negative, or if $b < a$ while y is positive, *i.e.*, in moving along the curve from $x=a$ to $x=b$, we are moving parallel to the negative direction of the x -axis, the calculated area will be negative.

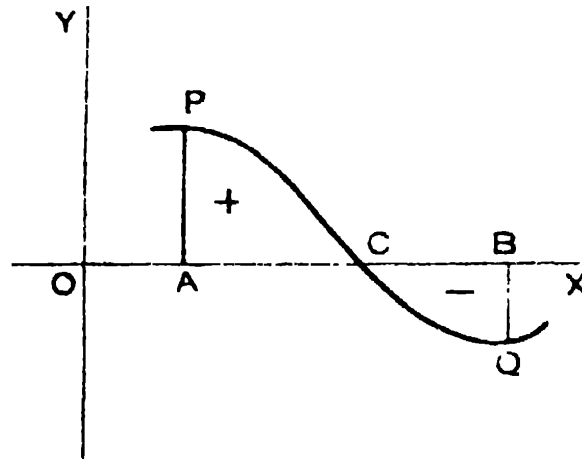

FIG. (i)

If therefore we proceed to calculate the total area where, in the range (a, b) , y is positive for some portion and negative for the rest, as in the above figure (i), by using the formula $\int_a^b y \, dx$, the calculated result will give us the difference of the magnitudes of the two areas ACP and CQB , which may be positive or negative or even zero if the magnitudes of the two areas are equal.

Hence, if our object be to get the sum-total of the magnitudes of the two areas, we should calculate the part

separately by formulæ of the type $\int_a^c y dx$, $\int_c^b y dx$, the results being found to be associated with their proper signs. We shall now discard the signs and consider the sum of the magnitudes.

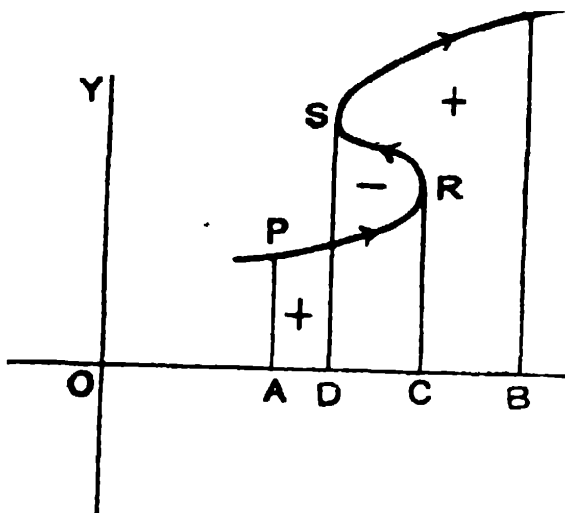
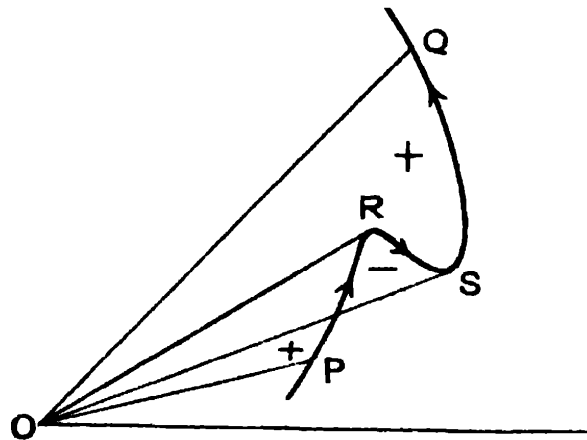

FIG. (ii)

In each individual case therefore we should first of all have a clear idea of the figure and the area to be calculated, and then we should proceed. For instance, notice that in fig. (ii) area $PACR$ is +, area $CRSD$ -, and area $SDBQ$ +, and that for the range DC of the x -axis, y is three-valued and in calculating the area $PACR$ we are to use one value of y for the portion in the formula $\int_a^c y dx$, for calculating the area $CRSD$ we are to use a second value of y in the formula $\int_c^d y dx$, the upper limit d being less than c for this part, and lastly for the area $SDBQ$ we are to use the third value of y for this part in the formula $\int_d^b y dx$. If we take the algebraic sum of the three areas, with their proper

signs, we get the area bounded by the curve, the x -axis and the ordinates AP and BQ .

Similarly, in the formula $\frac{1}{2} \int_a^\beta r^2 d\theta$ in polar co-ordinates if $\beta < a$, *i.e.*, if θ diminishes in moving along the curve from $\theta = a$ to $\theta = \beta$, the calculated area will be negative. Then



area OPR is +, area ORS is -, area OSQ +, the area bounded by $PRSQ$ and the radii vectors OP, OQ , being their algebraic sum. Also for the range SOR , for each value of θ , r has three values, and we must use the right value in each case for that part when moving along PR or along RS or along SQ in the expression $r^2 d\theta$.

9.5. Area of closed curves.

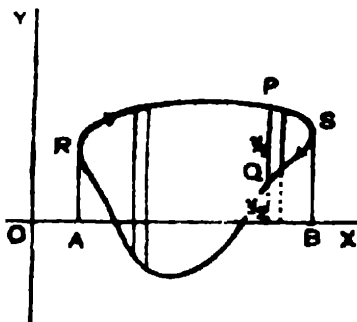

FIG. (i)

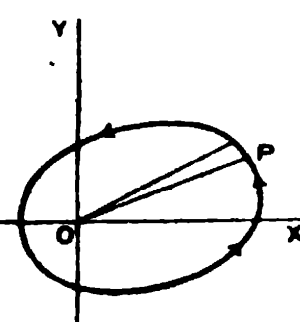

FIG. (ii)

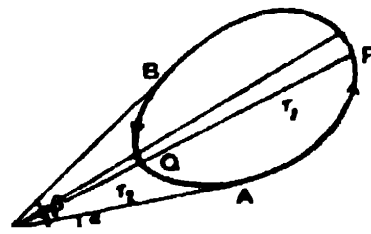

FIG. (iii)

In a closed curve given by Cartesian equation, clearly for each value of x there will be two values of y , say y_1 and y_2 (See *Fig. 1*). The extreme values of y , say a and b , are obtained by putting $y_1 = y_2$. Now, $\int_a^b (y_1 - y_2) dx$ will give the positive value of the required area provided $b > a$ and $y_1 > y_2$. This amounts as it were, to the determination of the area between two curves having the same equation as the given one, but y being single-valued in each, the proper value being chosen for each part. The method has been illustrated in Ex. 2, Art. 9'2.

In polar curves, if the origin be within the curve, (See *Fig. 2*), $\frac{1}{2} \int_0^{2\pi} r^2 d\theta$ gives the desired area.

If the origin be outside, corresponding to each value of θ there are two values of r , say r_1 and r_2 (See *Fig. 3*). The extreme values of θ , namely α and β , are obtained by putting $r_1 = r_2$. Now, if $r_1 > r_2$ and $\beta > \alpha$, the positive value of the area will be given by the expression $\frac{1}{2} \int_\alpha^\beta (r_1^2 - r_2^2) d\theta$.

In fact the area $OAPB$ is given by $\frac{1}{2} \int_\alpha^\beta r_1^2 d\theta$ and is positive, while $\frac{1}{2} \int_\beta^\alpha r_2^2 d\theta$ gives the area $OBQA$, with negative sign, the algebraic sum of the two giving the desired area.

In the case of closed curves there is another method of calculating the area. Let x, y be the cartesian co-ordinates of a point on the curve whose polar co-ordinates are r, θ .

Then $x = r \cos \theta, y = r \sin \theta$.

If now t be a single variable parameter in terms of which x , y and therefore r , θ of any point on the curve can be expressed, we have,

$$\frac{dx}{dt} = \frac{dr}{dt} \cos \theta - r \sin \theta \frac{d\theta}{dt}$$

$$\frac{dy}{dt} = \frac{dr}{dt} \sin \theta + r \cos \theta \frac{d\theta}{dt}$$

$$\therefore x \frac{dy}{dt} - y \frac{dx}{dt} = r^2 \frac{d\theta}{dt}$$

Hence, *the area which is expressed by the integral $\frac{1}{2} \int r^2 d\theta$, can as well be expressed by the line integral*

$$\frac{1}{2} \int \left(x \frac{dy}{dt} - y \frac{dx}{dt} \right) dt$$

along the curve, the limits of t for the closed curve being such that the point (x, y) returns to its initial position. The rule of signs for the area is that the above expression is positive when the area lies to the left of a point describing the curve in the direction in which t increases.

9.6. Approximate evaluation of a definite integral: Simpson's rule.

In many cases, a definite integral cannot be obtained either because the quantity to be integrated cannot be expressed as a mathematical function, or because the indefinite integral of the function itself cannot be determined directly. In such cases formulæ of approximation are used. One such important formula is Simpson's rule. By this rule the definite integral of any function (or the area bounded by a curve, the x -axis and two extreme ordinates) is expressed in terms of the individual values of any number of ordinates within the interval, by assuming that the function within

each of the small ranges into which the whole interval may be divided can be represented to a sufficient degree of approximation by a parabolic function.

Simpson's Rule: An approximate value of the definite integral

$$\int_a^b y \, dx \text{ where } y = f(x)$$

$$= \frac{1}{3}h [(y_1 + y_{2n+1}) + 2(y_3 + y_5 + \dots + y_{2n-1}) + 4(y_2 + y_4 + \dots + y_{2n})]$$

where $h = \frac{b-a}{2n}$ and y_1, y_2, y_3, \dots are the values of y when $x = a, a+h, a+2h, \dots$

In words, the above rule can be written as

$\frac{1}{3}h$ [sum of the extreme ordinates + 2.sum of the remaining odd ordinates + 4.sum of the even ordinates].

Let PQ be the curve $y=f(x)$ and PL, QM be the ordinates $x=a, x=b$. Divide the interval LM into $2n$ equal intervals each of length h by the points N_2, N_3, \dots

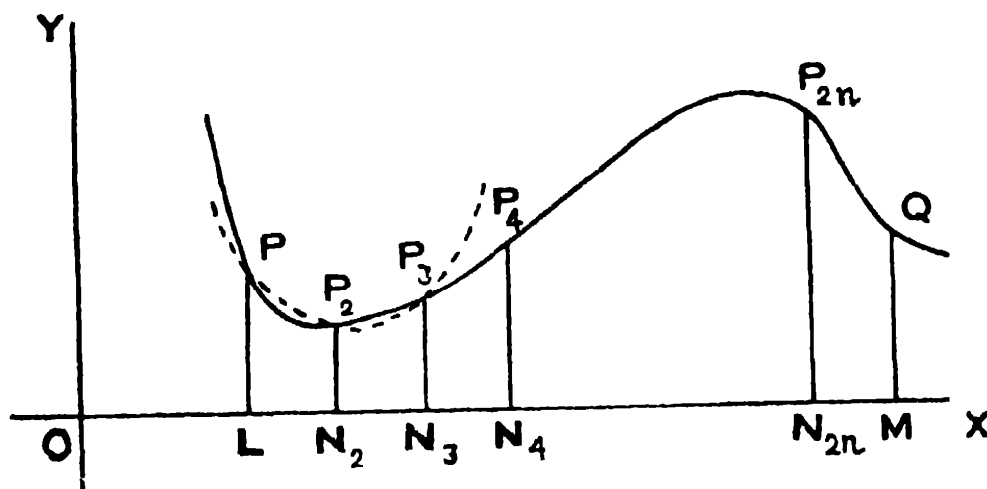

so that $h = \frac{b-a}{2n}$ and let P_2N_2, P_3N_3, \dots be the ordinates at N_2, N_3, \dots . Then $PL = y_1, P_2N_2 = y_2, P_3N_3 = y_3, \dots$

Through PP_2P_3 draw a parabola having its axis parallel to y -axis, and let its equation referred to parallel axes through $N_2(a+h, 0)$ be

$$y = a + bx + cx^2. \quad \dots \quad \dots \quad (1)$$

Then the area bounded by the parabolic arc PP_2P_3 , the ordinates of P, P_3 and the x -axis (such to be called hereafter shortly as area under the parabola)

$$= \int_{-h}^h (a + bx + cx^2) dx = 2h \left(a + \frac{1}{3}ch^2 \right). \quad \dots \quad (2)$$

$\therefore P(-h, y_1), P_2(0, y_2), P_3(h, y_3)$ are points on the parabola (1),

$$\therefore y_1 = a - bh + ch^2, y_2 = a, y_3 = a + bh + ch^2$$

from which we get $a = y_2, c = \frac{y_1 - 2y_2 + y_3}{2h^2}$.

$$\therefore \text{from (2), area under the parabola} = \frac{1}{3}h(y_1 + 4y_2 + y_3).$$

Now, area of the 1st strip (ordinates y_1, y_2, y_3) under the curve $y = f(x)$ is approximately = area under the parabola

$$= \frac{1}{3}h(y_1 + 4y_2 + y_3).$$

Similarly, area of the 2nd strip (ordinates y_3, y_4, y_5) under the curve is approximately = $\frac{1}{3}h(y_3 + 4y_4 + y_5)$;

area of the 3rd strip (ordinates y_5, y_6, y_7) under the curve is approximately = $\frac{1}{3}h(y_5 + 4y_6 + y_7)$;

and area of the n th strip under the curve is approximately

$$= \frac{1}{3}h(y_{2n-1} + 4y_{2n} + y_{2n+1}).$$

\therefore summing all these, *area under the curve i.e.,* $\int_a^b y dx$

is approximately

$$= \frac{1}{3}h [(y_1 + y_{2n+1}) + 2(y_3 + y_5 + \dots + y_{2n-1}) + 4(y_2 + y_4 + \dots + y_{2n})].$$

Note. It should be noted that the closer the ordinates, the more approximate is the value.

Simpson's rule is sometimes called '*Parabolic rule*'.

Ex. Given $e^0 = 1$, $e^1 = 2.72$, $e^2 = 7.39$, $e^3 = 20.09$, $e^4 = 54.60$; verify Simpson's rule by finding an approximate value of $\int_0^4 e^x dx$, taking 4 equal intervals, and compare it with its exact value.

Here, $a = 0$, $b = 4$, $n = 2$, $h = 1$, $y = f(x) = e^x$.

\therefore by Simpson's rule we get the approximate value

$$\begin{aligned} & \frac{1}{3}h [(y_1 + y_3) + 2y_2 + 4(y_0 + y_4)] \\ &= \frac{1}{3}h [(e^0 + e^4) + 2e^2 + 4(e^1 + e^3)] \\ &= \frac{1}{3}h [1 + 54.60 + 2 \times 7.39 + 4(2.72 + 20.09)] \\ &= 53.87. \end{aligned}$$

$$\text{Exact value} = \left[e^x \right]_0^4 = e^4 - 1 = 54.60 - 1 = 53.60.$$

\therefore error = $53.87 - 53.60 = .27$ approx.

EXAMPLES IX

1. Find the area of a hyperbola $xy = c^2$ bounded by the x -axis, and the ordinates $x = a$, $x = b$.

2. Find the area of the segment of the parabola $y = (x-1)(4-x)$ cut off by the x -axis.

3. Find the area bounded by the x -axis and one arc of the sine curve $y = \sin x$.

4. In the logarithmic curve $y = ae^x$, show that the area between the x -axis and any two ordinates is proportional to the difference between the ordinates.

5. Find by integration the area of the triangle bounded by the line $y = 3x$, the x -axis and the ordinates $x = 2$. Verify your result by finding the area as half the product of the base and the altitude.

6. Show that the area bounded by the parabola $\sqrt{x} + \sqrt{y} = \sqrt{a}$, and the co-ordinate axes, is $\frac{1}{6}a^2$.

7. Show that the area bounded by the semi-cubical parabola $y^2 = ax^3$, and a double ordinate, is $\frac{2}{3}$ of the area of the rectangle formed by this ordinate and the abscissa.

8. Show that the area of

(i) the astroid $x^{\frac{2}{3}} + y^{\frac{2}{3}} = a^{\frac{2}{3}}$ is $\frac{3}{8}\pi a^2$;

(ii) the hypo-cycloid $\left(\frac{x}{a}\right)^{\frac{2}{3}} + \left(\frac{y}{b}\right)^{\frac{2}{3}} = 1$ is $\frac{3}{8}\pi ab$;

(iii) the evolute $(ax)^{\frac{2}{3}} + (by)^{\frac{2}{3}} = (a^2 - b^2)^{\frac{2}{3}}$ is $\frac{3}{8}\pi \frac{(a^2 - b^2)^2}{ab}$.

9. Find the area enclosed by the curves : ($a > 0$)

(i) $x(1+t^2) = 1-t^2$; $y(1+t^2) = 2t$.

(ii) $x = 3 \cos t$; $y = 2 \sin t$.

(iii) $x = a \cos t (1 - \cos t)$; $y = a \sin t (1 - \cos t)$.

(iv) $x = a (2 \cos t + \cos 2t)$; $y = a (\sin t + \sin 2t)$.

10. Find the area of the segment cut off from $y^2 = 4x$ by the line $y = 2x$.

11. Find the area bounded by the curve $y^2 = x^3$ and the line $y = x$.

12. Find the area of the portion of the circle $x^2 + y^2 = 1$, which lies inside the parabola $y^2 = 1 - x$.

13. (i) Show that the area bounded by the parabolas $y^2 = 4ax$ and $x^2 = 4ay$, is $\frac{16}{3}a^2$. [C. P. 1928]

(ii) Find the area bounded by the curves

$$y^2 - 4x - 4 = 0, \text{ and } y^2 + 4x - 4 = 0.$$

14. Prove that the curves $y^2 = 4x$ and $x^2 = 4y$ divide the square bounded by $x = 0$, $x = 4$, $y = 0$, $y = 4$ into three equal areas.

15. The curves $y = 4x^2$ and $y^2 = 2x$ meet at the origin O and at the point P , forming a loop. Show that the straight line OP divides the loop into two parts of equal area.

16. (i) Find the area included between the ellipses $x^2 + 2y^2 = a^2$ and $2x^2 + y^2 = a^2$.

(ii) Show that the area common to the two ellipses

$$\frac{x^2}{a^2} + \frac{y^2}{b^2} = 1, \text{ and } \frac{x^2}{b^2} + \frac{y^2}{a^2} = 1, (a > b)$$

is $2ab \tan^{-1} \frac{2ab}{a^2 - b^2}$.

17. Find the area of the following curves : ($a > 0$)

(i) $a^2 y^2 = a^2 x^2 - x^4$. [P. P. 1935]

(ii) $(y - x)^2 = a^2 - x^2$.

[See Ex. 2, Art. 9'2]

(iii) $(x^2 + y^2)^2 = a^2 (x^2 - y^2)$.

(iv) $(x^2 + y^2)^2 = a^2 x^2 + b^2 y^2$.

[Transform (iii) and (iv) to Polar]

(v) $x = a \cos \theta + b \sin \theta$, $y = a' \cos \theta + b' \sin \theta$.

(vi) $x = a \sin 2t$, $y = a \sin t$.

18. Find the area of the loop of each of the following curves : ($a > 0$)

(i) $y^2 = x(x - 1)^2$.

(ii) $ay^2 = x^2(a - x)$.

(iii) $y^2 = x^2(x + a)$.

[C. P. 1935]

$$(iv) \quad x = \frac{1-t^2}{1+t^2}, \quad y = t \cdot \frac{1-t^2}{1+t^2} \quad (-1 \leq t \leq 1)$$

$$(v) \quad x = a(1-t^2), \quad y = at(1-t^2), \quad (-1 \leq t \leq 1).$$

19. Find the area of the loop or one of the two loops (where such exist) of the following curves: ($a > 0$)

$$(i) \quad x(x^2 + y^2) = a(x^2 - y^2).$$

$$(ii) \quad y^2(a^2 + x^2) = x^2(a^2 - x^2).$$

$$(iii) \quad y^2(a - x) = x^2(a + x).$$

$$(iv) \quad y^2 = x^2(4 - x^2).$$

$$(v) \quad x^2 = y^2(2 - y).$$

20. Find the whole area included between each of the following curves and its asymptote: ($a > 0$)

$$(i) \quad x^2 y^2 = a^2(y^2 - x^2).$$

$$(ii) \quad y^2(a - x) = x^3.$$

$$(iii) \quad y^2(a - x) = x^2(a + x).$$

$$(iv) \quad x^2 y^2 + a^2 b^2 = a^2 y^2.$$

$$(v) \quad xy^2 = 4a^2(2a - x).$$

21. Find the area of the following curves: ($a > 0$)

$$(i) \quad r = a \sin \theta.$$

$$(ii) \quad r^2 = a^2 \sin 2\theta; \quad r^2 = a^2 \cos 2\theta.$$

$$(iii) \quad r^2(a^2 \sin^2 \theta + b^2 \cos^2 \theta) = a^2 b^2.$$

$$(iv) \quad r = a \sin 3\theta.$$

$$(v) \quad r = a (\sin 2\theta + \cos 2\theta).$$

$$(vi) \quad r^2 = a^2 \cos^2 \theta + b^2 \sin^2 \theta.$$

$$(vii) \quad r = 3 + 2 \cos \theta.$$

22. Show that

(i) the area included between the hyperbolic spiral $r\theta = a$ and any two radii vectores, is proportional to the difference between the lengths of those radii vectores.

(ii) the area included between the logarithmic spiral $r = e^{a\theta}$ and any two radii vectores, is proportional to the difference between the squares of those radii vectores.

23. Find the area of a loop of the curves : ($a > 0$)

(i) $x^4 + y^4 = 2a^2xy$. [*C. P. 1932*]

[*Transform to Polar*]

(ii) $r^2 = a^2 \cos 2\theta$. [*C. P. 1932, '38*]

(iii) $r^2 = a^2 \cos 4\theta$. [*C. P. 1924*]

24. Find the area of the ellipse

$$9x^2 + 4y^2 - 18x - 16y - 11 = 0.$$

25. If for the curve $x(x^2 + y^2) = a(x^2 - y^2)$, ($a > 0$) A be the area between the curve and its asymptote and L be the area of its loop, show that $A + L = 4a^2$.

26. Show that for the curve

$$y^2(a + x) = x^2(3a - x), \quad (a > 0)$$

the area of its loop and the area between the curve and its asymptote are both equal to $(3\sqrt{3})a^2$.

27. Show that the area included between one of the branches of the curve $x^2y^2 = a^2(x^2 + y^2)$ ($a > 0$) and its asymptote is equal to the total area of the curve $(x^2 + y^2)^2 = a^2(x^2 - y^2)$, ($a > 0$).

28. If $p = f(r)$ be the equation of a curve, show that its

$$\text{area} = \frac{1}{2} \int \frac{pr}{\sqrt{r^2 - p^2}} dr$$

taken between the proper limits.

29. If $p=f(\psi)$ be the equation of a curve, show that its

$$\text{area} = \frac{1}{2} \int p \left(p + \frac{d^2 p}{d\psi^2} \right) d\psi$$

taken between the proper limits.

30. (i) Show that the sectorial area of the equi-angular spiral $p=r \sin \alpha$ included between the two radii vectores r_1 and r_2 , is $\frac{1}{2}(r_2^2 - r_1^2) \tan \alpha$.

(ii) Show that the area of the lemniscate $a^2 p = r^3$ is a^2 .

[For half a loop r varies from 0 to a]

31. Find an approximate value of

$$\int_0^{0.2} (1 - 2x^2)^{\frac{1}{3}} dx, \text{ taking 2 equal intervals.}$$

Given $f(0.1) = 0.99334$, $f(0.2) = 0.9725$ where

$$f(x) = (1 - 2x^2)^{\frac{1}{3}}.$$

32. Find the approximate value of

$$\int_1^2 \frac{dx}{x}, \text{ taking 10 equal intervals, and calculate}$$

the error.

Given $f(1.1) = .90909$

$f(1.6) = .62500$

$f(1.2) = .83333$

$f(1.7) = .58824$

$f(1.3) = .76923$

$f(1.8) = .55556$

$f(1.4) = .71429$

$f(1.9) = .52632$

$f(1.5) = .66667$

where $f(x) = \frac{1}{x}$.

33. Evaluate

$$\int_0^{\frac{1}{2}\pi} \sqrt{2 + \sin x} \, dx, \text{ using 4 equal intervals,}$$

given when $x = 0^\circ 0'$, $22^\circ 30'$, $45^\circ 0'$, $67^\circ 30'$, $90^\circ 0'$,

$$\sqrt{2 + \sin x} = 1.414, 1.544, 1.645, 1.710, 1.732.$$

34. Obtain an approximate value of

$$\int_0^1 \frac{dx}{1+x^2} \text{ taking 4 equal intervals, and hence}$$

obtain an approximate value of π correct to four places of decimals.

35. A river is 80 ft. wide. The depth d in feet at a distance x ft. from one bank is given by the following table.

$x = 0$	10	20	30	40	50	60	70	80
$d = 0$	4	7	9	12	15	14	8	3

Find approximately the area of the cross-section.

36. Use Simpson's rule, taking five ordinates, to find approximately to two places of decimals the value of

$$\int_1^2 \sqrt{x - 1/x} \, dx.$$

ANSWERS

- | | | | | |
|------------------------------|---|---------------------------------------|-----------------------------|--------------------------------------|
| 1. $c^2 \log \frac{b}{a}$. | 2. $4\frac{1}{2}$. | 3. 2. | 9. (i) π . | (ii) 6π . |
| (iii) $\frac{3}{2}\pi a^2$. | (iv) $6\pi a^2$. | 10. $\frac{8}{3}$. | 11. 3.2 . | 12. $\frac{1}{2}\pi + \frac{4}{3}$. |
| 13. (ii) $\frac{1}{3}a^2$. | 16. (i) $2\sqrt{2}a^2 \sin^{-1} \frac{1}{\sqrt{3}}$. | 17. (i) $\frac{4}{3}a^2$. | (ii) πa^2 . | |
| (iii) a^2 . | (iv) $\frac{1}{2}\pi(a^2 + b^2)$. | (v) $\pi(ab' - a'b)$. | (vi) $\frac{8}{3}a^2$. | |
| 18. (i) $\frac{8}{15}$. | (ii) $\frac{8}{15}a^2$. | (iii) $\frac{8}{15}a^{\frac{5}{2}}$. | (iv) $2 - \frac{1}{2}\pi$. | (v) $\frac{8}{15}a^2$. |

19. (i) $2a^2(1 - \frac{1}{4}\pi)$. (ii) $a^2(\frac{1}{2}\pi - 1)$. (iii) $2a^2(1 - \frac{1}{4}\pi)$. (iv) $\frac{1}{3}a^2$. (v) $2\frac{2}{15}a^2$.
20. (i) $4a^2$. (ii) $\frac{3}{2}\pi a^2$. (iii) $2a^2(1 + \frac{1}{4}\pi)$. (iv) $2\pi ab$. (v) $4\pi a^2$.
21. (i) $\frac{1}{4}\pi a^2$. (ii) $a^2; a^2$. (iii) πab . (iv) $\frac{1}{4}\pi a^2$.
 (v) πa^2 . (vi) $\frac{1}{2}\pi(a^2 + b^2)$. (vii) 11π .
23. (i) $\frac{1}{4}\pi a^2$. (ii) $\frac{1}{2}a^2$. (iii) $\frac{1}{4}a^2$. 24. 6π . 31. 0.1982 .
32. $.69315$; error = $.00001$. 33. 2.546 . 34. 3.1416 .
35. 710 sq. ft. 36. 0.84 .
-

CHAPTER X
LENGTHS OF PLANE CURVES.

[*Rectification*]*

10·1. Lengths determined from Cartesian Equations.

We know from Differential Calculus that if s be the length of the arc of a curve measured from a fixed point A on it to any point P , whose Cartesian co-ordinates are (a, b) and (x, y) respectively, then

$$\frac{ds}{dx} = \sec \psi = \sqrt{1 + \tan^2 \psi} = \sqrt{1 + \left(\frac{dy}{dx}\right)^2},$$

ψ denoting the angle made by the tangent at P to the x -axis.

Thus, we can write

$$s = \int \sqrt{1 + \left(\frac{dy}{dx}\right)^2} dx + C,$$

where $\frac{dy}{dx}$ is expressed in terms of x from the equation to the curve, and C is the integration constant. If the indefinite integral $\int \sqrt{1 + \left(\frac{dy}{dx}\right)^2} dx$ be denoted by $F(x)$, then since $s=0$ when P coincides with A , i.e., when $x=a$, we get

$$0 = F(a) + C, \text{ whence } C = -F(a).$$

Thus,

$$s = F(x) - F(a) = \int_a^x \sqrt{1 + \left(\frac{dy}{dx}\right)^2} dx.$$

*The process of finding the length of an arc of a curve, i.e., 'of finding a straight line whose length is the same as that of a specified arc', is called *Rectification*. For the definition of the *length* of an arc of a curve, see Authors' Differential Calculus, Appendix.

Hence, between two points having x_1 and x_2 as abscissæ, the length of the curve is given by

$$\begin{aligned} s_2 - s_1 &= \int_a^{x_2} \sqrt{1 + \left(\frac{dy}{dx}\right)^2} dx - \int_a^{x_1} \sqrt{1 + \left(\frac{dy}{dx}\right)^2} dx \\ &= \int_{x_1}^{x_2} \sqrt{1 + \left(\frac{dy}{dx}\right)^2} dx. \quad \dots (1) \end{aligned}$$

If it be convenient to get $\frac{dy}{dx}$, and accordingly $\frac{dx}{dy}$, in terms of y , instead of x , from the equation to the curve, we can use the result

$$\frac{ds}{dy} = \sqrt{1 + \left(\frac{dx}{dy}\right)^2},$$

whence the length AP is given by

$$\int_b^y \sqrt{1 + \left(\frac{dx}{dy}\right)^2} dy,$$

where $\frac{dx}{dy}$ is expressed in terms of y .

Also the length of the curve between the two points whose ordinates are y_1 and y_2 respectively will be

$$s_2 - s_1 = \int_{y_1}^{y_2} \sqrt{1 + \left(\frac{dx}{dy}\right)^2} dy. \quad \dots (2)$$

If both x and y are expressed in terms of a common variable parameter t , and so s is also a function of t , we can write

$$\begin{aligned} \frac{ds}{dt} &= \frac{ds}{dx} \cdot \frac{dx}{dt} = \sqrt{1 + \left(\frac{dy}{dx}\right)^2} \cdot \frac{dx}{dt} \\ &= \sqrt{\left(\frac{dx}{dt}\right)^2 + \left(\frac{dy}{dt}\right)^2} \cdot \left[\because \frac{dy}{dt} = \frac{dy}{dx} \frac{dx}{dt} \right] \end{aligned}$$

Thus as before, the length of the curve between two points on it for which $t = t_1$ and $t = t_2$ respectively will be given by

$$s_2 - s_1 = \int_{t_1}^{t_2} \sqrt{\left(\frac{dx}{dt}\right)^2 + \left(\frac{dy}{dt}\right)^2} dt. \quad \dots (3)$$

All the above cases can be included in a single result in the differential form

$$ds = \sqrt{dx^2 + dy^2}, \quad \dots \dots (4)$$

where the right-hand side is expressed in the differential form in terms of a single variable, from the given equation to the curve. This, when integrated between proper limits, gives the desired length of the curve.

Note. In the above formulæ (1), (2) and (3), it is assumed that $\frac{dy}{dx}$, $\frac{dx}{dy}$, $\frac{dx}{dt}$, $\frac{dy}{dt}$ are all continuous in the range of integration.

Illustrative Examples.

Ex. 1. Find the length of the arc of the parabola $y^2 = 4ax$ measured from the vertex to one extremity of the latus rectum.

$$\text{Here, } 2y \frac{dy}{dx} = 4a, \text{ or, } \frac{dy}{dx} = \frac{2a}{y} = \frac{2a}{\sqrt{4ax}} = \sqrt{\frac{a}{x}}.$$

The abscissæ of the vertex and one extremity of the latus rectum are 0 and a respectively. Hence, the required length

$$\begin{aligned} s &= \int_0^a \sqrt{1 + \left(\frac{dy}{dx}\right)^2} dx = \int_0^a \sqrt{\frac{x+a}{x}} dx \\ &= \int_0^a \frac{x+a}{\sqrt{x(x+a)}} dx \\ &= \left[\sqrt{x(x+a)} + a \log (\sqrt{x} + \sqrt{x+a}) \right]_0^a \\ &= a\{\sqrt{2} + \log (1 + \sqrt{2})\}. \end{aligned}$$

Ex. 2. Determine the length of an arc of the cycloid $x = a(\theta + \sin \theta)$, $y = a(1 - \cos \theta)$, measured from the vertex (i.e., the origin).

Here,

$$\begin{aligned} \frac{ds}{d\theta} &= \sqrt{\left(\frac{dx}{d\theta}\right)^2 + \left(\frac{dy}{d\theta}\right)^2} \\ &= a \sqrt{(1 + \cos \theta)^2 + \sin^2 \theta} = 2a \cos \frac{1}{2}\theta. \end{aligned}$$

Also at the origin, $\theta = 0$. Hence, the required length, from $\theta = 0$ to any point θ , is

$$s = \int_0^\theta 2a \cos \frac{1}{2}\theta \, d\theta = 4a \sin \frac{1}{2}\theta.$$

Cor. 1. Since at the extremity of the cycloid (i.e., at the cusp) $y = 2a$, we have $\theta = \pi$ there. Thus, the length of a complete cycloid being double the length from the vertex to the extremity, is $2 \cdot 4a \sin \frac{1}{2}\pi = 8a$.

Cor. 2. $s^2 = 16a^2 \sin^2 \frac{1}{2}\theta = 8a \cdot a(1 - \cos \theta) = 8ay$.

Ex. 3. Find the whole length of the loop of the curve

$$3ay^2 = x(x - a)^2.$$

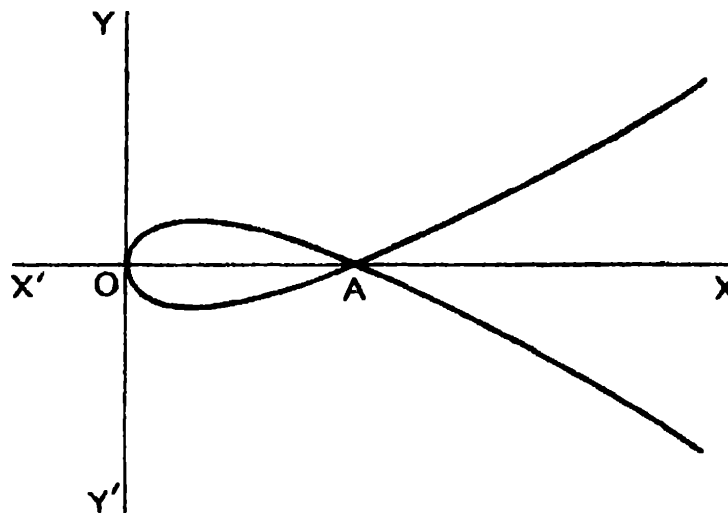

We notice here that, for negative values of x , y is imaginary, and so there is no part of the curve on the negative side of the x -axis. Again, at the points where $x = 0$ and $x = a$, we have $y = 0$. Between these two points, for every value of x there are two equal and opposite

values of y , a loop being thereby formed. For each value of x greater than a , y has two equal and opposite values, and with x increasing, y continually increases in magnitude. The curve is thus traced as in the adjoining figure. The extremities of the loop are given by $x=0$ and $x=a$.

Now from the equation to the curve,

$$6ay \frac{dy}{dx} = (x-a)^2 + 2x(x-a) = (x-a)(3x-a);$$

$$\begin{aligned} \frac{ds}{dx} &= \sqrt{1 + \left(\frac{dy}{dx}\right)^2} = \sqrt{1 + \frac{(x-a)^2(3x-a)^2}{36a^2y^2}} \\ &= \sqrt{1 + \frac{(3x-a)^2}{12ax}} = \frac{3x+a}{2\sqrt{3ax}}. \end{aligned}$$

\therefore the half length of the loop is

$$\begin{aligned} \int_0^a \frac{3x+a}{2\sqrt{3ax}} dx &= \frac{1}{2\sqrt{3a}} \left[3 \cdot \frac{2}{3} x^{\frac{3}{2}} + a \cdot 2\sqrt{x} \right]_0^a \\ &= \frac{1}{\sqrt{3a}} \left[2a^{\frac{3}{2}} \right] = \frac{2a}{\sqrt{3}} = \frac{2}{3} \sqrt{3}a. \end{aligned}$$

The whole length of the loop therefore, from the symmetry of the curve = $\frac{4}{3} \sqrt{3}a$.

10·2. Lengths determined from polar equations.

From the formulæ

$$\tan \phi = r \frac{d\theta}{dr}, \quad \cos \phi = \frac{dr}{ds}, \quad \sin \phi = r \frac{d\theta}{ds}$$

in Differential Calculus, where s represents the length of the arc of a curve from any fixed point A of it to a variable point P whose polar co-ordinates are r , θ and ϕ denotes the angle between the radius vector to the point and the tangent at the point, we can write

$$\frac{1}{r} \frac{ds}{d\theta} = \operatorname{cosec} \phi = \sqrt{1 + \cot^2 \phi} = \sqrt{1 + \frac{1}{r^2} \left(\frac{dr}{d\theta}\right)^2},$$

whence
$$\frac{ds}{d\theta} = \sqrt{r^2 + \left(\frac{dr}{d\theta}\right)^2}. \quad \dots \quad (i)$$

Again,

$$\frac{ds}{dr} = \sec \phi = \sqrt{1 + \tan^2 \phi} = \sqrt{1 + r^2 \left(\frac{d\theta}{dr}\right)^2}. \quad \dots \quad (ii)$$

From (i) and (ii), the length of an arc of the curve can be expressed in either of the forms

$$s = \int_{\theta_1}^{\theta_2} \sqrt{r^2 + \left(\frac{dr}{d\theta}\right)^2} d\theta,$$

$$r, \quad s = \int_{r_1}^{r_2} \sqrt{1 + r^2 \left(\frac{d\theta}{dr}\right)^2} dr,$$

where r_1, θ_1 and r_2, θ_2 are the polar co-ordinates of the extremities of the required arc. In the first form, r as also $\frac{dr}{d\theta}$ are expressed in terms of θ from the given polar equation to the curve. In the second form, $\frac{d\theta}{dr}$ is expressed in terms of r .

Both (i) and (ii) can be combined in a single differential form,

$$ds = \sqrt{dr^2 + r^2 d\theta^2}.$$

Note. It is assumed in the above formulae that $\frac{dr}{d\theta}, \frac{d\theta}{dr}$ are continuous in the range of integration.

Ex. Find the perimeter of the Cardioid $r = a(1 - \cos \theta)$, and show that the arc of the upper half of the curve is bisected by $\theta = \frac{3}{2}\pi$.

Here, since $r = a(1 - \cos \theta)$, $\frac{dr}{d\theta} = a \sin \theta$.

Hence, the length of any arc of the curve measured from the origin where $\theta = 0$, to any point, is given by

$$\begin{aligned} s &= \int_0^\theta \sqrt{r^2 + \left(\frac{dr}{d\theta}\right)^2} d\theta \\ &= \int_0^\theta \sqrt{a^2(1 - \cos \theta)^2 + a^2 \sin^2 \theta} d\theta \\ &= \int_0^\theta 2a \sin \frac{\theta}{2} d\theta = 4a \left[-\cos \frac{\theta}{2} \right]_0^\theta = 4a \left(1 - \cos \frac{\theta}{2} \right). \end{aligned}$$

Thus, the length of the upper half of the curve, which clearly extends from $\theta = 0$ to $\theta = \pi$, is $4a(1 - \cos \frac{1}{2}\pi) = 4a$.

[See Fig., Ex. 1, Art. 9'3]

The whole perimeter is clearly double of this, and thus $= 8a$.

Again, the length of the curve from $\theta = 0$ to $\theta = \frac{2}{3}\pi$ is $4a(1 - \cos \frac{1}{3}\pi) = 2a$, and so the line $\theta = \frac{2}{3}\pi$ bisects the arc of the upper half of the curve.

10'3. Lengths determined from pedal equations.

From the formulæ $\frac{dr}{ds} = \cos \phi$ and $p = r \sin \phi$ in Differential Calculus, we can write

$$\frac{ds}{dr} = \frac{1}{\cos \phi} = \frac{1}{\sqrt{1 - \sin^2 \phi}} = \frac{1}{\sqrt{1 - \frac{p^2}{r^2}}} = \frac{r}{\sqrt{r^2 - p^2}},$$

whence the length of an arc of the curve extending from $r = r_1$ to $r = r_2$ will be given by

$$s = \int_{r_1}^{r_2} \frac{r dr}{\sqrt{r^2 - p^2}}$$

where p is to be replaced in terms of r from the given pedal equation to the curve.

Ex. Find the length of the arc of the parabola $p^2 = ar$ from $r = a$ to $r = 2a$.

The required length is given by

$$\begin{aligned}
 s &= \int_a^{2a} \frac{r \, dr}{\sqrt{r^2 - a^2}} = \int_a^{2a} \frac{r \, dr}{\sqrt{r^2 - ar}} \\
 &= \left[\sqrt{r^2 - ar} + a \log (\sqrt{r} + \sqrt{r-a}) \right]_a^{2a} \\
 &= a \sqrt{2} + a \log (\sqrt{2} + 1) = a [\sqrt{2} + \log (1 + \sqrt{2})].
 \end{aligned}$$

10.4. Length of an Arc of an Evolute.

We know from Differential Calculus that the difference between the radii of curvature at two points of a given curve is equal to the length of the corresponding arc of its evolute.

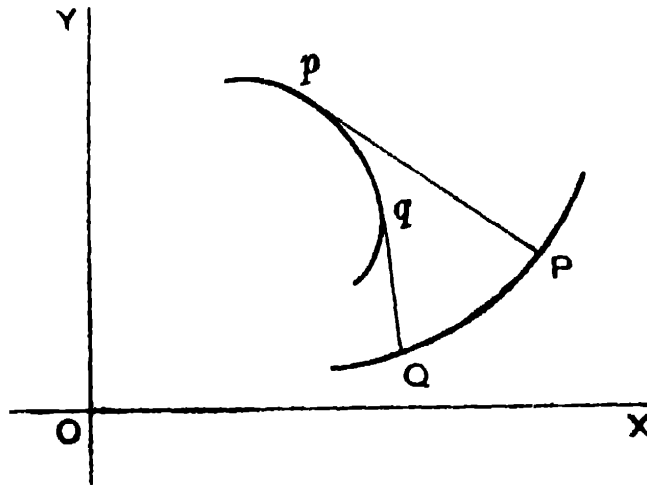

Thus, if ρ_1 and ρ_2 be the radii of curvature at P and Q of a given curve PQ , p and q being the corresponding points on the evolute, the length of the arc pq of the evolute $= \rho_1 - \rho_2$.

In fact p, q are the centres of curvature and so Pp and Qq are the radii of curvature at P and Q of the curve PQ , and if the evolute be regarded as a rigid curve, and a string be unwound from it, being kept tight, then the points of the unwinding string describe a system of parallel curves, one of which is the given curve PQ , of which pq is the evolute. PQ is called the involute of pq .

Ex. Calculate the entire length of the evolute of the ellipse

$$\frac{x^2}{a^2} + \frac{y^2}{b^2} = 1.$$

[C. P. 1918]

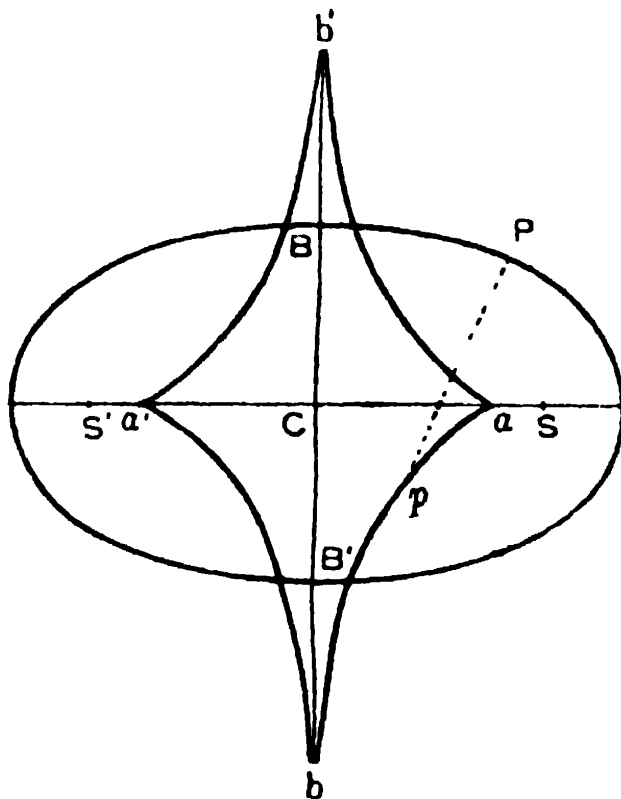

a, b, a', b' being the centres of curvature of the ellipse at A, B, A', B' respectively, the evolute, as shown in the figure, consists of four similar portions, the portion apb corresponding to the part APB of the given ellipse.

Now, from Differential Calculus, it is known that at any point on the ellipse, the radius of curvature

$$\rho = \frac{a^2 b^2}{p^3},$$

where p is the perpendicular from the centre on the tangent at the point.

Thus, the length of the arc apb of the evolute

$$= \rho_B - \rho_A = \frac{a^2 b^2}{b^3} - \frac{a^2 b^2}{a^3} = \frac{a^2}{b} - \frac{b^2}{a}.$$

Hence, the entire length of the evolute of the ellipse

$$= 4 \left(\frac{a^2}{b} - \frac{b^2}{a} \right).$$

10.5. Intrinsic Equation to a Curve.

If s denotes the length of an arc of a plane curve measured from some fixed point A on it, up to an arbitrary point P , and if ψ be the inclination of the tangent to the curve at P to any fixed line on the plane (e.g., the x -axis), the relation between s and ψ is called the *Intrinsic Equation* of the curve.

It should be noted that the intrinsic equation of a curve determines only the form of the curve, and not its position on the plane.

(A) Intrinsic Equation derived from Cartesian Equation.

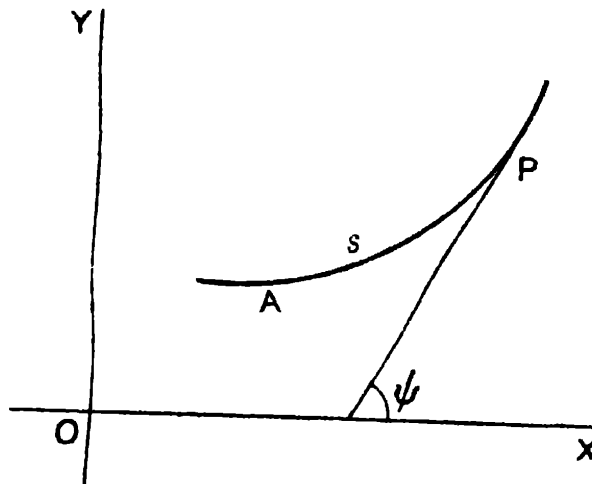

Let the Cartesian equation to the curve be $y = f(x)$. Then ψ denoting the angle between the tangent at any point P and the x -axis,

$$\tan \psi = \frac{dy}{dx} = f'(x). \quad \dots \quad \dots \quad (i)$$

$$\text{Also, } s = \text{arc } AP = \int_a^x \sqrt{1 + \left(\frac{dy}{dx}\right)^2} dx$$

$$= \int_a^x \sqrt{1 + \{f'(x)\}^2} dx = F(x), \text{ say} \quad \dots \quad (ii)$$

' a ' denoting the abscissa A , and ' x ' that of P .

Now, the x -eliminant between (i) and (ii), (which will be a relation between s and ψ) will be the required intrinsic equation of the curve.

If the equation to the curve be given in the *parametric form* $x = f(t)$, $y = \phi(t)$,

we can write

$$\tan \psi = \frac{dy}{dx} = \frac{dy}{dt} \bigg/ \frac{dx}{dt} = \frac{\phi'(t)}{f'(t)}. \quad \dots \quad (i)$$

$$\begin{aligned} \text{Also, } s &= \int_{t_1}^t \sqrt{\left(\frac{dx}{dt}\right)^2 + \left(\frac{dy}{dt}\right)^2} dt \\ &= \int_{t_1}^t \sqrt{\{f'(t)\}^2 + \{\phi'(t)\}^2} dt \\ &= F(t) \text{ say,} \quad \dots \quad \dots \quad (ii) \end{aligned}$$

where t_1 is the value of the parameter t at A .

The t -eliminant between (i) and (ii) will be the required intrinsic equation to the curve.

(B) Intrinsic Equation derived from Polar Equation.

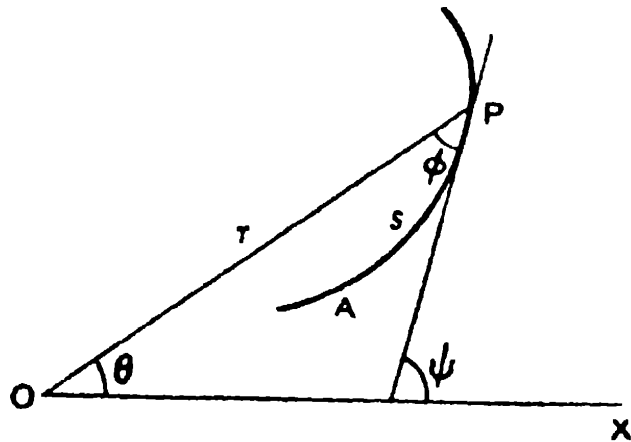

Let $r = f(\theta)$ be the polar equation to a curve.

Let ϕ denote the angle between the tangent and the radius vector at any point $P(r, \theta)$, ψ the angle made by the

tangent with the initial line, and s the length of the arc AP where $A(a, \alpha)$ is a fixed point on the curve.

$$\text{Then, } \tan \phi = r \frac{d\theta}{dr} = \frac{f(\theta)}{f'(\theta)} \quad \dots \quad \dots \quad (i)$$

$$\psi = \theta + \phi, \quad \dots \quad \dots \quad (ii)$$

$$\begin{aligned} \text{and } s &= \int_{\alpha}^{\theta} \sqrt{r^2 + \left(\frac{dr}{d\theta}\right)^2} d\theta \\ &= \int_{\alpha}^{\theta} \sqrt{\{f(\theta)\}^2 + \{f'(\theta)\}^2} d\theta = F(\theta) \text{ say. } (iii) \end{aligned}$$

Now, eliminating ϕ and θ between (i), (ii) and (iii), we get a relation between s and ψ , which is the required intrinsic equation of the curve.

(C) Intrinsic Equation derived from Pedal Equation.

Let $p = f(r)$ be the pedal equation to the curve.

Then, as in Art. 10'3,

$$s = \int_{\alpha}^r \frac{r dr}{\sqrt{r^2 - p^2}} = \int_{\alpha}^r \frac{r dr}{\sqrt{r^2 - \{f(r)\}^2}} = F(r) \text{ say. } \quad \dots \quad (i)$$

Also, from Differential Calculus, ρ denoting radius of curvature,

$$\frac{ds}{d\psi} = \rho = r \frac{dr}{dp} = \frac{r}{f'(r)} \quad \dots \quad (ii)$$

Eliminating r between (i) and (ii), we get a relation of the form

$$\frac{ds}{d\psi} = \phi(s), \text{ or, } \frac{d\psi}{ds} = \frac{1}{\phi(s)} \quad \therefore \quad \psi = \int \frac{ds}{\phi(s)}$$

which, when the right side is integrated, will give the required intrinsic equation.

Illustrative Examples.

Ex. 1. Obtain the intrinsic equation of the Catenary $y = c \cosh \frac{x}{c}$ in the form $s = c \tan \psi$.

$$\text{Here, } \tan \psi = \frac{dy}{dx} = \sinh \frac{x}{c}. \quad (i)$$

Also measuring s from the vertex, where $x = 0$,

$$\begin{aligned} s &= \int_0^x \sqrt{1 + \left(\frac{dy}{dx}\right)^2} dx \\ &= \int_0^x \sqrt{1 + \sinh^2 \frac{x}{c}} dx \\ &= \int_0^x \cosh \frac{x}{c} dx = \left[c \sinh \frac{x}{c} \right]_0^x = c \sinh \frac{x}{c}. \end{aligned}$$

Hence, from (i), $s = c \tan \psi$.

Ex. 2. Obtain the intrinsic equation of the cycloid

$$x = a(\theta + \sin \theta), \quad y = a(1 - \cos \theta)$$

taking the vertex as the fixed point and the tangent at that point as the fixed line. [C. P. 1928, '32]

As shown in Ex. 2, Art. 10'1, the length of the arc of the above cycloid measured from the vertex is given by

$$s = 4a \sin \frac{\theta}{2} \quad (i)$$

$$\text{Also, } \tan \psi = \frac{dy}{dx} = \frac{dy/d\theta}{dx/d\theta} = \frac{a \sin \theta}{a(1 + \cos \theta)} = \tan \frac{\theta}{2}.$$

$$\therefore \psi = \frac{\theta}{2}. \quad \text{Hence, from (i), } s = 4a \sin \psi$$

which is the required intrinsic equation.

Ex. 3. Find the intrinsic equation of the Cardioid

$$r = a(1 - \cos \theta),$$

the arc being measured from the cusp (i.e., where $\theta = 0$).

[C. P. 1937, '49]

Here, $\psi = \theta + \phi$ (1)

and $\tan \phi$, i.e., $r \frac{d\theta}{dr} = \frac{1 - \cos \theta}{\sin \theta} = \tan \frac{\theta}{2}$.

$\therefore \phi = \frac{1}{2}\theta$ (2)

Also by the Ex., Art. 10'2, we have,

$$s = \int_0^\theta \sqrt{r^2 + \left(\frac{dr}{d\theta}\right)^2} d\theta = 4a \left(1 - \cos \frac{\theta}{2}\right). \quad \dots (3)$$

Since, from (1) and (2), $\psi = \theta + \frac{1}{2}\theta = \frac{3}{2}\theta$, i.e., $\theta = \frac{2}{3}\psi$,

\therefore from (3), $s = 4r(1 - \cos \frac{1}{3}\psi)$,

the required intrinsic equation.

Ex. 4. Find the Cartesian equation of the curve for which the intrinsic equation is $s = a\psi$.

Here, $\frac{dx}{d\psi} = \frac{dx}{ds} \cdot \frac{ds}{d\phi} = \cos \psi \cdot a$.

$\therefore dx = a \cos \psi d\psi$. $\therefore x = a \sin \psi + c$ (1)

Again, $\frac{dy}{d\psi} = \frac{dy}{ds} \cdot \frac{ds}{d\psi} = \sin \psi \cdot a$.

$\therefore dy = a \sin \psi d\psi$. $\therefore y = -a \cos \psi + d$ (2)

From (1) and (2), eliminating ψ , we get

$$(x - c)^2 + (y - d)^2 = a^2, \text{ the required Cartesian equation.}$$

EXAMPLES X

1. Find the lengths of the following :

(i) the perimeter of the circle $x^2 + y^2 = a^2$;

(ii) the arc of the catenary $y = \frac{a}{2} \left(e^{\frac{x}{a}} + e^{-\frac{x}{a}} \right)$ from

the vertex to the point (x_1, y_1) ;

(iii) the perimeter of the astroid $x^{\frac{2}{3}} + y^{\frac{2}{3}} = a^{\frac{2}{3}}$;

[C. P. 1941, '44]

(iv) the perimeter of the hypocycloid $\left(\frac{x}{a}\right)^{\frac{2}{3}} + \left(\frac{y}{b}\right)^{\frac{2}{3}} = 1$;

(v) the perimeter of the evolute $(ax)^{2/3} + (by)^{2/3} = (a^2 - b^2)^{2/3}$.

(vi) the arc of the semi-cubical parabola $ay^2 = x^3$ from the cusp to any point (x, y) . [C. P. 1924]

2. If s be the length of an arc of $3ay^2 = x(x-a)^2$ measured from the origin to the point (x, y) , show that $3s^2 = 4x^2 + 3y^2$.

3. Show that the length of the arc of the parabola $y^2 = 4ax$ which is intercepted between the points of intersection of the parabola and the straight line $3y = 8x$ is $a(\log 2 + \frac{1}{2}\sqrt{3})$.

4. Show that the complete perimeter of the curve

$$x = \frac{1-t^2}{1+t^2}, \quad y = \frac{2t}{1+t^2}, \text{ is } 2\pi.$$

5. If for a curve

$$x \sin \theta + y \cos \theta = f'(\theta),$$

and $x \cos \theta - y \sin \theta = f''(\theta),$

show that $s = f(\theta) + f''(\theta) + c,$

where c is a constant.

6. Find the length of the arcs of the following curves :

(i) $\left. \begin{array}{l} x = e^\theta \sin \theta \\ y = e^\theta \cos \theta \end{array} \right\}$ from $\theta = 0$ to $\theta = \frac{1}{2}\pi$.

(ii) $\left. \begin{array}{l} x = a(\cos \theta + \theta \sin \theta) \\ y = a(\sin \theta - \theta \cos \theta) \end{array} \right\}$ from $\theta = 0$ to $\theta = \theta_1$.

$$\text{(iii) } \left. \begin{aligned} x &= c \sin 2\theta (1 + \cos 2\theta) \\ y &= c \cos 2\theta (1 - \cos 2\theta) \end{aligned} \right\}$$

from the origin to any point.

7. Show that the perimeter of the ellipse $x = a \cos \theta$, $y = b \sin \theta$, is given by

$$2a\pi \left\{ 1 - \left(\frac{1}{2}\right)^2 \frac{e^2}{1} - \left(\frac{1.3}{2.4}\right)^2 \frac{e^4}{3} - \left(\frac{1.3.5}{2.4.6}\right)^2 \frac{e^6}{5} - \dots \right\}.$$

8. Compare the perimeters of the two conics

$$\frac{x^2}{9} + \frac{y^2}{7} = 1 \quad \text{and} \quad \frac{x^2}{36} + \frac{y^2}{28} = 1. \quad [C. H. 1925]$$

9. Find the lengths of the loop of each of the following curves :

$$\text{(i) } 9y^2 = (x+7)(x+4)^2; \quad [P. P. 1934]$$

$$\text{(ii) } x = t^2, y = t - \frac{1}{3}t^3.$$

10. Find the lengths of the following :

(i) a quadrant of the circle $r = 2a \sin \theta$;

(ii) the arc of the parabola $r(1 + \cos \theta) = 2$ from $\theta = 0$ to $\theta = \frac{1}{2}\pi$;

(iii) the arc of the equi-angular spiral $r = ae^{\theta \cot \alpha}$ between the radii vectores r_1 and r_2 .

11. If s be the length of the curve $r = a \tanh \frac{1}{2}\theta$ between the origin and $\theta = 2\pi$, and Δ the area between the same points, show that $\Delta = a(s - a\pi)$. [C. P. 1931]

12. Show that the area between the curve

$$y = \frac{a}{2} \left(e^{\frac{x}{a}} + e^{-\frac{x}{a}} \right),$$

the x -axis, and the ordinates at two points on the curve,

is equal to a times the length of the arc terminated by those points. [Nagpur, 1936]

13. Show that in the astroid $x^{\frac{2}{3}} + y^{\frac{2}{3}} = a^{\frac{2}{3}}$,

(i) $s \propto x^{\frac{2}{3}}$,

(ii) $\rho^2 + 4s^2 = 6as$,

s being measured from the point for which $x = 0$.

14. Show that

(i) in the cycloid $x = a(\theta + \sin \theta)$, $y = a(1 - \cos \theta)$,

$$\rho^2 + s^2 = 16a^2,$$

the arc being measured from the vertex (where $\theta = 0$);

[C. H. 1933]

(ii) in the catenary $y = c \cosh \frac{x}{c}$,

$$y^2 = c\rho = c^2 + s^2,$$

the arc being measured from the vertex; [C. P. 1930]

(iii) in the cardioid $r = a(1 + \cos \theta)$, $s^2 + 9\rho^2 = 16a^2$,

the arc being measured from the vertex (i.e., $\theta = 0$).

15. Show that the length of the arc of the hyperbola $xy = a^2$ between the points $x = b$ and $x = c$ is equal to the arc of the curve $p^2(a^4 + r^4) = a^4 r^2$ between the limits $r = b$ and $r = c$.

16. Show that the length of the arc of the evolute $27ay^2 = 4(x - 2a)^3$ of the parabola $y^2 = 4ax$, from the cusp to one of the points where the evolute meets the parabola, is $2a(3\sqrt{3} - 1)$.

17. Find the intrinsic equation of each of the following curves, the fixed point from which the arc is measured being indicated in each case :

(i) the parabola $y^2 = 4ax$ (vertex),

(ii) the astroid $x^{\frac{2}{3}} + y^{\frac{2}{3}} = a^{\frac{2}{3}}$ (one of cusps),

(iii) the semi-cubical parabola $ay^2 = x^3$ (cusp),

(iv) the curve $y = a \log \sec \frac{x}{a}$ (origin),

(v) the equi-angular spiral $r = ae^{\theta \cot \alpha}$... (point $a, 0$),

(vi) the involute of the circle, *viz.*,

$$\theta = \frac{\sqrt{r^2 - a^2}}{a} - \cos^{-1} \frac{a}{r} \dots \text{(point } a, 0).$$

18. Find the intrinsic equation of each of the following curves :

(i) $p = r \sin \alpha$,

(ii) $p^2 = r^2 - a^2$.

19. Find the intrinsic equation of the curve for which the length of the arc measured from the origin varies as the square root of the ordinate. Also obtain the Cartesian co-ordinates of any point on the curve in terms of any parameter. [C. P. 1931]

20. If $s = c \tan \psi$ is the intrinsic equation of a curve, show that the Cartesian equation is $y = c \cosh \frac{x}{c}$, given that when $\psi = 0$, $x = 0$ and $y = c$. [C. P. 1926]

ANSWERS

1. (i) $2\pi a$. (ii) $\frac{1}{2}a \left(e^{\frac{x_1}{a}} - e^{-\frac{x_1}{a}} \right)$. (iii) $6a$.
- (iv) $4 \frac{a^2 + ab + b^2}{a + b}$. (v) $4 \left(\frac{a^2}{b} - \frac{b^2}{a} \right)$.
- (vi) $\frac{8a}{27} \left\{ \left(1 + \frac{9x}{4a} \right)^{\frac{3}{2}} - 1 \right\}$.
6. (i) $\sqrt{2}(e^{\frac{1}{2}\pi} - 1)$. (ii) $\frac{1}{2}a\theta,^2$. (iii) $\frac{4}{3}c \sin 3\theta$.
8. $1 : 2$. 9. (i) $4\sqrt{3}$. (ii) $4\sqrt{3}$.
10. (i) $\frac{1}{2}\pi a$. (ii) $\sqrt{2} + \log(\sqrt{2} + 1)$. (iii) $(r_2 - r_1) \sec \alpha$.
17. (i) $s = a \operatorname{cosec} \psi \cot \psi + a \log(\operatorname{cosec} \psi + \cot \psi)$. (ii) $s = \frac{3}{2}a \sin^2 \psi$.
- (iii) $27s = 8a(\sec^3 \psi - 1)$. (iv) $s = a \log \tan \left(\frac{1}{2}\psi + \frac{1}{4}\pi \right)$.
- (v) $s = a \sec \alpha \{ e^{(\psi - \alpha) \cot \alpha} - 1 \}$. (vi) $s = \frac{1}{2}a\psi^2$.
18. (i) $s = Ce^{\psi \cot \alpha}$. (ii) $s = \frac{1}{2}a\psi^2$.
19. $s = 4a \sin \psi$, $x = a(\theta + \sin \theta)$, $y = a(1 - \cos \theta)$.
-

CHAPTER XI
 VOLUMES AND SURFACE-AREAS OF
 SOLIDS OF REVOLUTION

11.1. Solids of revolution, the axis of revolution being the x -axis.

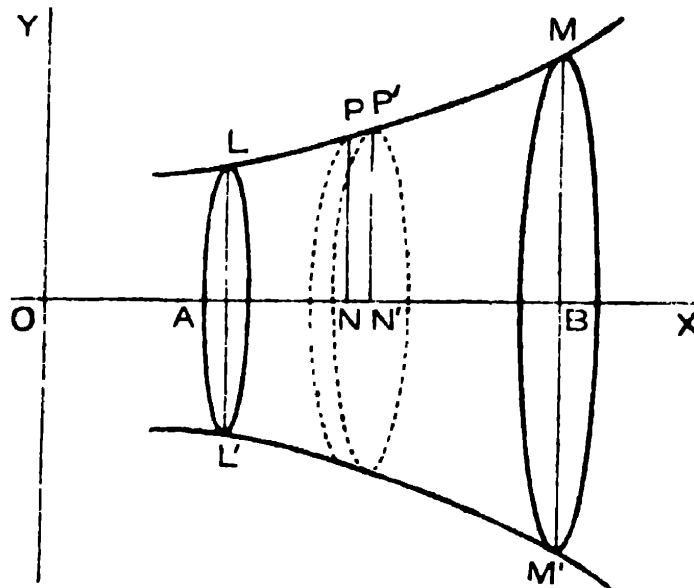

Let a curve LM , whose Cartesian equation is given, $y = f(x)$ say, be rotated about the x -axis, so as to form a solid of revolution, and let us consider the portion $LL'M'M$ of this solid bounded by $x = x_1$ and $x = x_2$ respectively. We can imagine this solid to be divided into an infinite number of infinitely thin circular slices by planes perpendicular to the axis of revolution OX . If PN and $P'N'$ be two adjacent ordinates of the curve, where the co-ordinates of P and P' are (x, y) and $(x + \Delta x, y + \Delta y)$ respectively, the

volume of the corresponding slice, which has thickness Δx , is ultimately equal to $\pi y^2 \Delta x$.*

Hence, the total volume of the solid considered (bounded by $x = x_1$ and $x = x_2$) is given by

$$V = \lim_{\Delta x \rightarrow 0} \sum \pi y^2 \Delta x = \pi \int_{x_1}^{x_2} y^2 dx.$$

Again, if Δs be the element of length PP' , s being the arc length measured up to P from any fixed point on the curve LM , the surface-area of the ring-shaped element generated by rotating PP' is ultimately $2\pi y \cdot \Delta s$.

Hence, the required surface-area is given by

$$S = \lim_{\Delta s \rightarrow 0} \sum (2\pi y \Delta s) = 2\pi \int_{s_1}^{s_2} y ds.$$

[s_1, s_2 being the values of s for the points L, M]

$$= 2\pi \int_{x_1}^{x_2} y \cdot \sqrt{1 + \left(\frac{dy}{dx}\right)^2} dx.$$

Cor. 1. When the axis of revolution is the y -axis, and we consider the portion of the solid bounded by $y = y_1$ and $y = y_2$ respectively,

$$V = \pi \int_{y_1}^{y_2} x^2 dy,$$

$$\text{and } S = 2\pi \int_{s_1}^{s_2} x ds = 2\pi \int_{y_1}^{y_2} x \sqrt{1 + \left(\frac{dx}{dy}\right)^2} dy.$$

Cor. 2. Even if the curve revolved be given by its polar equation (the axis of revolution being the initial line), and the portion of the

*Strictly, the volume of the slice lies between $\pi y_1^2 \Delta x$ and $\pi y_2^2 \Delta x$ where y_1 and y_2 are the greatest and the least values of y within the range PP' , and thus equals $\pi y^2 \Delta x$, where y lies between y_1 and y_2 and is thus the ordinate for some point within the range PP' (not necessarily of P). Thus, $\lim \sum \pi y^2 \Delta x = \int y^2 dx$. [See Art. 6'2, Note 2.]

volume considered be bounded by two parallel planes perpendicular to the initial line, we may change to corresponding Cartesian coordinates, with the initial line as the x -axis, by writing $x = r \cos \theta$, $y = r \sin \theta$.

Thus,

$$V = \pi \int_{x_1}^{x_2} y^2 dx = \pi \int_{\theta_1}^{\theta_2} r^2 \sin^2 \theta \cdot d(r \cos \theta)$$

$$S = 2\pi \int_{s_1}^{s_2} y ds = 2\pi \int_{\theta_1}^{\theta_2} r \sin \theta \cdot \sqrt{dr^2 + r^2 d\theta^2},$$

where r is expressed in terms of θ from the given equation of the curve, or, if convenient, we may use r as the independent variable, and express θ in terms of r from the equation, the limits being the corresponding values of r .

Note. For an alternative method of proof see *Appendix*.

Illustrative Examples.

Ex. 1. Find the volume and area of the curved surface of a paraboloid of revolution formed by revolving the parabola $y^2 = 4ax$ about the x -axis, and bounded by the section $x = x_1$.

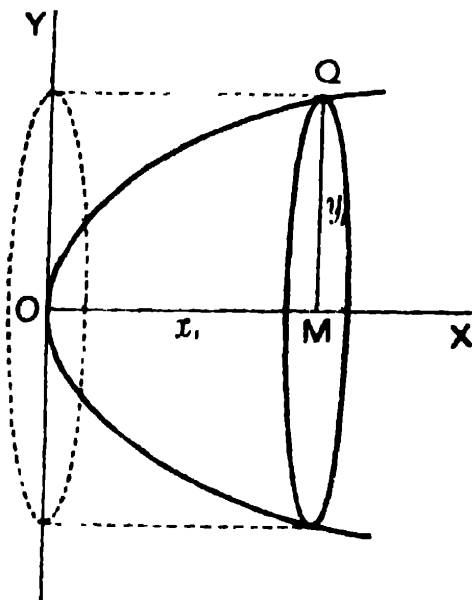

Here, $y = 2\sqrt{ax}$. $\therefore \frac{dy}{dx} = \sqrt{\frac{a}{x}}$.

Now the required volume

$$V = \pi \int_0^{x_1} y^2 dx = \pi \int_0^{x_1} 4ax dx = 2\pi ax_1^2 = \frac{1}{2}\pi x_1 y_1^2$$

(where y_1 is the extreme ordinate, so that $y_1^2 = 4ax_1$)

$= \frac{1}{2}\pi y_1^2 x_1 = \frac{1}{2}$. (the volume of the corresponding cylinder, with the extreme circular section as the base and height equal to the abscissa).

Also, the required surface-area

$$\begin{aligned} S &= 2\pi \int_0^{x_1} y \sqrt{1 + \left(\frac{dy}{dx}\right)^2} dx = 2\pi \int_0^{x_1} \sqrt{4ax} \sqrt{1 + \frac{a}{x}} dx \\ &= 4\pi \sqrt{a} \int_0^{x_1} \sqrt{a+x} dx = \frac{8}{3} \pi \sqrt{a} \left\{ (a+x_1)^{\frac{3}{2}} - a^{\frac{3}{2}} \right\}. \end{aligned}$$

Ex. 2. The part of the parabola $y^2 = 4ax$ bounded by the latus rectum revolves about the tangent at the vertex. Find the volume and the area of the curved surface of the reel thus generated.

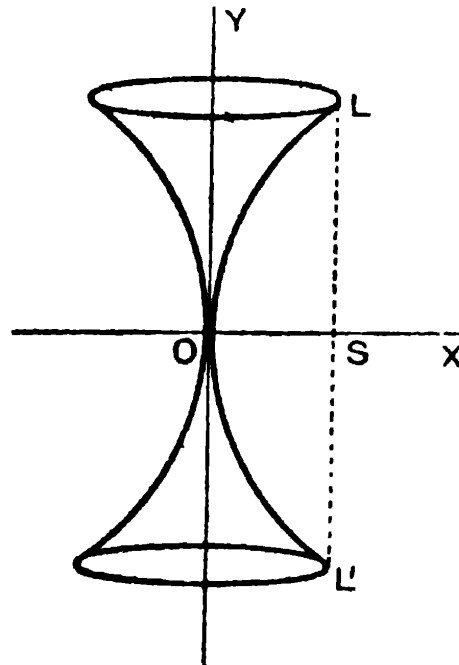

Here the axis of revolution being the y -axis, and the extreme values of y being evidently $\pm 2a$,

the required volume

$$\begin{aligned} V &= \pi \int_{-2a}^{+2a} x^2 dy = \pi \int_{-2a}^{+2a} \frac{y^4}{16a^2} dy \quad [\because y^2 = 4ax] \\ &= \frac{\pi}{16a^2} \cdot 2 \frac{(2a)^5}{5} = \frac{4}{5} \pi a^3. \end{aligned}$$

Also, the required surface-area

$$\begin{aligned} S &= 2\pi \int x ds = 2\pi \int_{-2a}^{+2a} x \sqrt{1 + \left(\frac{dx}{dy}\right)^2} dy \\ &= 2\pi \int_{-2a}^{+2a} \frac{y^2}{4a} \sqrt{1 + \frac{y^2}{4a^2}} dy \quad \left[\because \frac{dx}{dy} = \frac{y}{2a} \right] \\ &= 4\pi a^2 \int_{-\frac{1}{2}\pi}^{+\frac{1}{2}\pi} \tan^2 \theta \sec^3 \theta d\theta \quad [\text{putting } y = 2a \tan \theta] \\ &= 4\pi a^2 \int_{-\frac{1}{2}\pi}^{+\frac{1}{2}\pi} (\sec^5 \theta - \sec^3 \theta) d\theta \\ &= 4\pi a^2 \left[\frac{1}{4} \tan \theta \sec^2 \theta - \frac{1}{8} \tan \theta \sec \theta - \frac{1}{8} \log \tan \left(\frac{1}{2}\pi + \frac{1}{2}\theta \right) \right]_{-\frac{1}{2}\pi}^{+\frac{1}{2}\pi} \\ &= 4\pi a^2 \left[\frac{3}{4} \sqrt{2} - \frac{1}{4} \log (\cot \frac{1}{2}\pi) \right] = \pi a^2 [3 \sqrt{2} - \log (\sqrt{2} + 1)]. \end{aligned}$$

Ex. 3. Find the volume and the surface-area of the solid generated by revolving the cycloid $x = a(\theta + \sin \theta)$, $y = a(1 + \cos \theta)$ about its base.

The equations show that the cycloid has its base as the x -axis; the extreme values of x are given by $\theta = \pm \pi$, i.e., $x = \pm a\pi$.

The required volume

$$\begin{aligned} V &= \pi \int_{-a\pi}^{a\pi} y^2 dx = \pi a^3 \int_{-\pi}^{\pi} (1 + \cos \theta)^3 d\theta \\ &= 8\pi a^3 \int_{-\pi}^{\pi} \cos^6 \frac{1}{2}\theta d\theta = 8\pi a^3 \cdot \frac{5}{8} \pi = 5\pi^2 a^3. \end{aligned}$$

The required surface-area

$$\begin{aligned} S &= 2\pi \int y ds = 2\pi \int y \sqrt{dx^2 + dy^2} \\ &= 2\pi \int_{-\pi}^{\pi} a(1 + \cos \theta) \cdot \sqrt{\{a(1 + \cos \theta) d\theta\}^2 + \{-a \sin \theta d\theta\}^2} \\ &= 2\pi a^2 \int_{-\pi}^{\pi} (1 + \cos \theta) \sqrt{2(1 + \cos \theta)} d\theta \\ &= 8\pi a^2 \int_{-\pi}^{\pi} \cos^3 \frac{1}{2}\theta d\theta = 8\pi a^2 \cdot \frac{8}{3} = \frac{64}{3} \pi a^2. \end{aligned}$$

Ex. 4. Find the volume and surface-area of the solid generated by revolving the cardioid $r = a(1 - \cos \theta)$ about the initial line.

Here, since the curve is symmetrical about the initial line, the solid of revolution might as well be considered to be formed by revolving the upper half of the curve about the initial line. The extreme points of the curve are given by $\theta = 0$ and $\theta = \pi$.

The required volume

$$\begin{aligned} V &= \pi \int y^2 dx = \pi \int r^2 \sin^2 \theta \cdot d(r \cos \theta) \\ &= \pi a^3 \int (1 - \cos \theta)^2 \sin^2 \theta \cdot d\{(1 - \cos \theta) \cos \theta\} \\ &= \pi a^3 \int_{\pi}^0 (1 - \cos \theta)^2 \sin^2 \theta (-\sin \theta + 2 \sin \theta \cos \theta) d\theta \\ &\quad [x \text{ increases as } \theta \text{ diminishes from } \pi \text{ to } 0] \\ &= \pi a^3 \int_{-1}^{+1} (1 - z)^2 (1 - z^2) (1 - 2z) dz \quad [\text{putting } z = \cos \theta] \\ &= \frac{8}{3} \pi a^3. \end{aligned}$$

The required surface-area

$$\begin{aligned} S &= 2\pi \int y ds = 2\pi \int r \sin \theta \cdot \sqrt{dr^2 + r^2 d\theta^2} \\ &= 2\pi \int_0^{\pi} a(1 - \cos \theta) \cdot \sin \theta \cdot \sqrt{(a \sin \theta d\theta)^2 + a^2(1 - \cos \theta)^2 d\theta^2} \\ &= 2\pi a^2 \int_0^{\pi} (1 - \cos \theta) \sin \theta \sqrt{2(1 - \cos \theta)} d\theta \\ &= 2\sqrt{2} \pi a^2 \int_0^2 z^{\frac{5}{2}} dz \quad [\text{putting } z = 1 - \cos \theta] \\ &= 2\sqrt{2} \pi a^2 \cdot \frac{2}{5} (2)^{\frac{5}{2}} = \frac{32}{5} \pi a^2. \end{aligned}$$

11.2. Solids of revolution, axis of revolution being any line in the plane.

If the given curve LM be revolved about any line AB in its plane, and the portion considered of the solid of

revolution formed be bounded by the planes perpendicular to AB through the points A and B respectively, then PN being the perpendicular on AB from any point P on the curve, $P'N'$ the contiguous perpendicular, the volume of the portion considered is given by

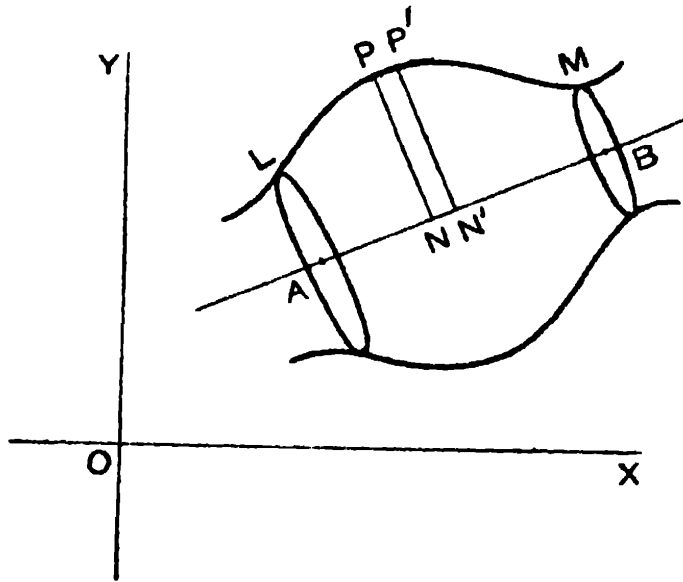

$$V = Lt \sum \pi \cdot PN^2 \cdot NN' = \pi \int_0^{AB} PN^2 \cdot d(AN).$$

Also, the surface-area of the portion considered is given by,

$$S = Lt \sum 2\pi PN \text{ (elementary arc } PP') = 2\pi \int PN \cdot ds.$$

From the given equation of the curve and of the line AB , PN , as also AN and ds are expressed in terms of a single variable, and the corresponding values of the variable for the points A and B are taken as the limits of integration.

Ex. *A quadrant of a circle, of radius a , revolves round its chord. Find the volume and the surface-area of the solid spindle thus generated.*

P being any point on the quadrant APB , where $\angle AOP = \theta$, clearly $AP = 2a \sin \frac{1}{2}\theta$, and $\angle PAN = \frac{1}{2}\angle POB = \frac{1}{2}(\frac{1}{2}\pi - \theta)$.

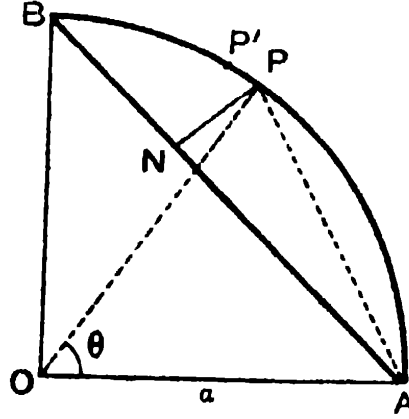

$$\therefore P'N = 2a \sin \frac{1}{2}\theta \sin (\frac{1}{2}\pi - \frac{1}{2}\theta) = a \{ \cos (\theta - \frac{1}{2}\pi) - \cos \frac{1}{2}\pi \}$$

$$AN = 2a \sin \frac{1}{2}\theta \cos (\frac{1}{2}\pi - \frac{1}{2}\theta) = a \{ \sin \frac{1}{2}\pi + \sin (\theta - \frac{1}{2}\pi) \}.$$

Elementary arc $PP' = a d\theta$.

Also for the solid formed, limits of θ are 0 and $\frac{1}{2}\pi$ respectively.

$$\text{Hence, } V = \pi \int PN^2 \cdot d(AN)$$

$$= \pi a^3 \int_0^{\frac{1}{2}\pi} \{ \cos (\theta - \frac{1}{2}\pi) - \cos \frac{1}{2}\pi \}^2 \cos (\theta - \frac{1}{2}\pi) d\theta$$

$$= \pi a^3 \int_0^{\frac{1}{2}\pi} [\cos^3 (\theta - \frac{1}{2}\pi) - \sqrt{2} \cos^2 (\theta - \frac{1}{2}\pi) + \frac{1}{2} \cos (\theta - \frac{1}{2}\pi)] d\theta$$

$$= \pi a^3 \int_0^{\frac{1}{2}\pi} \left[\frac{1}{4} \cos (3\theta - \frac{3}{2}\pi) + \frac{5}{4} \cos (\theta - \frac{1}{2}\pi) - \frac{1}{\sqrt{2}} \{ \cos (2\theta - \frac{1}{2}\pi) + 1 \} \right] d\theta$$

$$= \pi a^3 \left[\frac{1}{12} \sin (3\theta - \frac{3}{2}\pi) - \frac{1}{2\sqrt{2}} \sin (2\theta - \frac{1}{2}\pi) + \frac{5}{4} \sin (\theta - \frac{1}{2}\pi) - \frac{1}{\sqrt{2}} \theta \right]_0^{\frac{1}{2}\pi}$$

$$= \pi a^3 \left(\frac{10 - 3\pi}{6\sqrt{2}} \right).$$

$$\begin{aligned}
 \text{Also, } S &= 2\pi \int_0^{\frac{1}{2}\pi} PN.a \, d\theta \\
 &= 2\pi a^2 \int_0^{\frac{1}{2}\pi} \{ \cos(\theta - \frac{1}{4}\pi) - \cos \frac{1}{4}\pi \} \, d\theta \\
 &= 2\pi a^2 \left[\sin(\theta - \frac{1}{4}\pi) - \frac{1}{\sqrt{2}}\theta \right]_0^{\frac{1}{2}\pi} \\
 &= 2\pi a^2 \left(2 \cdot \frac{1}{\sqrt{2}} - \frac{\pi}{2\sqrt{2}} \right) = \pi a^2 \left(\frac{4-\pi}{\sqrt{2}} \right).
 \end{aligned}$$

11.3. Theorem of Pappus or Guldin.

If a plane area bounded by a closed curve revolves through any angle about a straight line in its own plane, which does not intersect the curve, then

(I) *The volume of the solid generated is equal to the product of the revolving area into the length of the arc described by the centroid of the area.*

(II) *The surface-area of the solid generated is equal to the product of the perimeter of the revolving area into the length of the arc described by the centroid of that perimeter.*

Proof.

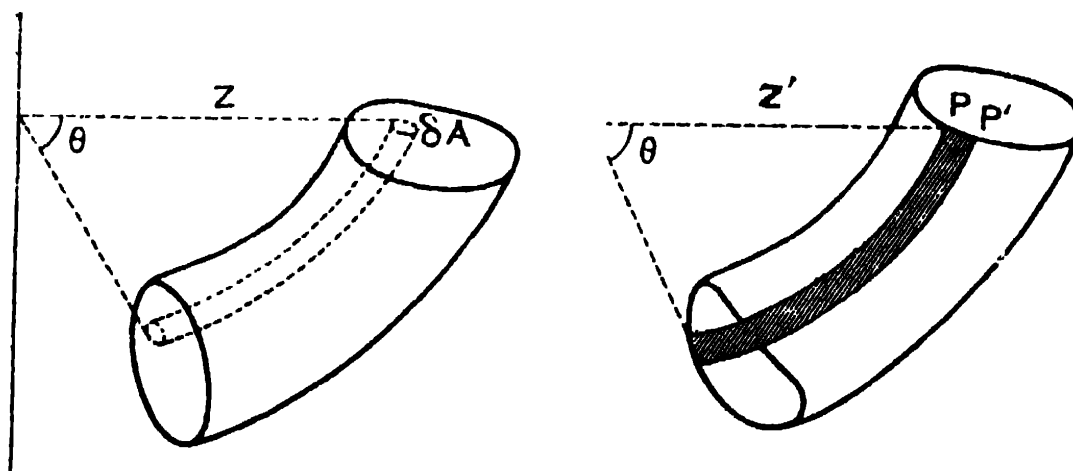

(I) Let δA be any element of the area whose distance from the axis of rotation is z . Then θ being the angle

through which the area is rotated, the length of the arc described by δA is $z\theta$, and hence the elementary volume described by the element δA is $z\theta \cdot \delta A$.

The whole volume described by the given area therefore
 $= \Sigma z\theta \cdot \delta A = \theta \Sigma z \cdot \delta A = \theta \bar{z} A$ (From *Elementary Statics*)

[where A is the total area of the curve and \bar{z} is the distance of its centroid from the axis of revolution]

$= A\bar{z}\theta = \text{area of the closed curve} \times \text{length of the arc}$
 described by its centroid.

(II) Let δs be the length of any element PP' of the perimeter of the given curve, and z' its distance from the axis of revolution. The elementary surface traced out by the element δs is ultimately $z'\theta \cdot \delta s$.

The total surface-area of the solid generated is therefore
 $= \Sigma z'\theta \cdot \delta s = \theta \Sigma z' \cdot \delta s = \theta \bar{z}' s$ (From *Elementary Statics*)

[where s is the whole perimeter of the curve, and \bar{z}' the distance of the centroid of this perimeter from the axis]

$= s \cdot \bar{z}'\theta = \text{perimeter} \times \text{length of the arc described by}$
 its centroid.

Note. The above results hold even if the axis of rotation touch the closed curve.

Ex. 1. Find the volume and surface-area of a solid tyre, a being the radius of its section, and b that of the core.

The tyre is clearly generated by revolving a circle of radius a about an axis whose distance from the centre of the circle is b .

The centre of the circle is the centroid of both the area of the circle as also of the perimeter of the circle, and the length of the path described by it is evidently $2\pi b$.

Hence, the required volume $= \pi a^2 \times 2\pi b = 2\pi^2 a^2 b$

and the required surface-area $= 2\pi a \times 2\pi b = 4\pi^2 ab$.

Ex. 2. Show that the volume of the solid formed by the rotation about the line $\theta=0$ of the area bounded by the curve $r=f(\theta)$ and the lines $\theta=\theta_1$, $\theta=\theta_2$ is

$$\frac{2}{3}\pi \int_{\theta_1}^{\theta_2} r^3 \sin\theta \, d\theta.$$

Hence, find the volume of the solid generated by revolving the cardioid $r=a(1-\cos\theta)$ about the initial line.

Dividing the area in question into an infinite number of elementary areas (as in the figure, § 9'3) by radial lines through the origin, let us consider one such elementary area bounded by the radii vectors inclined at angles θ and $\theta+d\theta$ to the initial line, their lengths being r and $r+dr$ say. This elementary area is ultimately in the form of a triangle whose area is $\frac{1}{2}r(r+dr)\sin d\theta$, i.e., $\frac{1}{2}r^2 d\theta$ up to the first order. Its C. G. is, neglecting infinitesimals, at a distance $\frac{2}{3}r$ from the origin and its perpendicular distance from the initial line is ultimately $\frac{2}{3}r \sin\theta$. The elementary volume obtained by revolving the elementary area about the initial line is therefore by Pappus' theorem, ultimately equal to

$$2\pi \cdot \frac{2}{3}r \sin\theta \cdot \frac{1}{2}r^2 d\theta = \frac{2}{3}\pi r^3 \sin\theta \, d\theta.$$

Hence, integrating between the extreme limits $\theta=\theta_1$ and $\theta=\theta_2$, the total volume of the solid of revolution in question is

$$\frac{2}{3}\pi \int_{\theta_1}^{\theta_2} r^3 \sin\theta \, d\theta.$$

In case of the cardioid $r=a(1-\cos\theta)$, the extreme limits for θ are easily seen to be 0 and π , and so the volume of the solid of revolution generated by it is

$\frac{2}{3}\pi \int_0^\pi a^3 (1-\cos\theta)^3 \sin\theta \, d\theta$, which on putting $1-\cos\theta=z$ easily reduces to

$$\frac{2}{3}\pi a^3 \int_0^2 z^3 \, dz = \frac{2}{3}\pi a^3 \cdot \frac{2^4}{4} = \frac{8}{3}\pi a^3.$$

EXAMPLES XI

1. Find the volumes of the solids generated by revolving about the x -axis, the areas bounded by the following curves and lines :

(i) $y = \sin x$; $x = 0$; $x = \pi$.

(ii) $y = 5x - x^2$; $x = 0$; $x = 5$.

(iii) $y^2 = 9x$; $y = 3x$.

(iv) $\sqrt{x} + \sqrt{y} = \sqrt{a}$; $x = 0$; $y = 0$.

2. Show that the volume of a right circular cone of height h and base of radius a is $\frac{1}{3}\pi a^2 h$.

3. The circle $x^2 + y^2 = a^2$ revolves round the x -axis ; show that the surface and the volume of the whole sphere generated are respectively $4\pi a^2$ and $\frac{4}{3}\pi a^3$. [C. P. 1941]

4. Prove that the surface and the volume of the ellipsoid formed by the revolution of the ellipse $\frac{x^2}{a^2} + \frac{y^2}{b^2} = 1$

(i) round its major axis are respectively

$$2\pi ab \left\{ \sqrt{1 - e^2} + e^{-1} \sin^{-1} e \right\} \text{ and } \frac{4}{3}\pi ab^2,$$

and (ii) round its minor axis are respectively

$$2\pi \left\{ a^2 + \frac{b^2}{e} \log \sqrt{\frac{1+e}{1-e}} \right\} \text{ and } \frac{4}{3}\pi a^2 b.$$

5. Show that the curved surface and volume of the catenoid formed by the revolution, about the x -axis, of the area bounded by the catenary $y = \frac{a}{2} \left(e^{\frac{x}{a}} + e^{-\frac{x}{a}} \right)$, the

y -axis, the x -axis, and an ordinate, are respectively

$$\pi (sy + ax) \text{ and } \frac{1}{2}\pi a (sy + ax),$$

s being the length of the arc between $(0, a)$ and (x, y) .

6. The arc of the astroid $x = a \cos^3 \theta$, $y = a \sin^3 \theta$, from $\theta = 0$ to $\theta = \frac{1}{2}\pi$ revolves about the x -axis; show that the volume and the surface-area of the solid generated are respectively $\frac{1}{105}\pi a^3$ and $\frac{6}{5}\pi a^2$.

7. A cycloid revolves round the tangent at the vertex; show that the volume and the surface-area of the solid generated are $\pi^2 a^3$ and $\frac{3}{5}\pi a^2$ respectively, a being the radius of the generating circle.

8. The portion between the two consecutive cusps of the cycloid $x = a(\theta + \sin \theta)$, $y = a(1 + \cos \theta)$ is revolved about the x -axis; show that the area of the surface so formed, is to the area of the cycloid, as 64 : 9. [Nagpur, 1934]

9. Show that the surface of the spherical zone contained between two parallel planes = $2\pi a \times$ the distance between the two planes, where a is the radius of the sphere.

10. Show that the volume of the solid generated by the revolution of the upper-half of the loop of the curve $y^2 = x^2(2-x)$ about OX is $\frac{4}{3}\pi$.

11. Show that the volume of the solid produced by the revolution of the loop of the curve $y^2(a+x) = x^2(a-x)$ about the x -axis is $2\pi a^3 (\log 2 - \frac{2}{3})$. [P. P. 1935]

12. Show that the surface-area and the volume of the solid generated by the revolution about the x -axis of the loop of the curve $x = t^2$, $y = t - \frac{1}{3}t^3$ are respectively 3π and $\frac{3}{4}\pi$.

13. The smaller of the two arcs into which the parabola $y^2 = 8ax$ divides the circle $x^2 + y^2 = 9a^2$ is rotated about the x -axis. Show that the volume of the solid generated is $\frac{2}{9}\pi a^3$.

14. If the curve $r = a + b \cos \theta$ ($a > b$), revolves about the initial line, show that the volume generated is

$$\frac{4}{3}\pi a (a^2 + b^2).$$

15. The following curves revolve round their asymptotes ; find the volume generated in each case :

(i) $y^2 (2a - x) = x^3.$

(ii) $y (a^2 + x^2) = a^3.$ [P. P. 1933]

(iii) $(a - x) y^2 = a^2 x.$

16. An arc of a parabola is bounded at both ends by the latus rectum of length $4a$. Find the volume generated when the arc is rotated about the latus rectum.

[Nagpur, 1935]

17. Show that the volume of the solid formed by revolving the ellipse $x = a \cos \theta$, $y = b \sin \theta$, about the line $x = 2a$, is $4\pi^2 a^2 b$.

18. Show that if the area lying within the cardioide $r = 2a (1 + \cos \theta)$ and outside the parabola $r(1 + \cos \theta) = 2a$ revolve about the initial line, the volume generated is $18\pi a^3$.

19. Show that the volume of the solid generated by revolution about OY of the area bounded by OY , the curve $y^2 = x^3$ and the line $y = 8$ is $\frac{384}{7}\pi$.

20. The arc of a parabola from the vertex to one extremity of the latus rectum is revolved about the corresponding chord. Prove that the volume of the spindle so formed is $\frac{2\sqrt{5}}{75} \pi a^3$.

ANSWERS

- | | | | |
|----------------------------|------------------------------|-------------------------------|-----------------------------|
| 1. (i) $\frac{1}{2}\pi^2.$ | (ii) $\frac{22}{3}\pi.$ | (iii) $\frac{3}{2}\pi.$ | (iv) $\frac{1}{15}\pi a^2.$ |
| 15. (i) $2\pi^2 a^3.$ | (ii) $\frac{1}{2}\pi^2 a^3.$ | (iii) $\frac{1}{2}\pi^2 a^3.$ | 16. $\frac{3}{2}\pi a^3.$ |

CHAPTER XII

CENTROIDS AND MOMENTS OF INERTIA

12.1. Centroid.

It has been proved in elementary statics that if a system of particles having masses m_1, m_2, m_3, \dots have their distances parallel to any co-ordinate axis given by x_1, x_2, x_3, \dots , then the corresponding co-ordinate of their centre of mass will be given by

$$\bar{x} = \frac{m_1 x_1 + m_2 x_2 + \dots}{m_1 + m_2 + \dots} = \frac{\Sigma m x}{\Sigma m}.$$

Similarly, $\bar{y} = \frac{\Sigma m y}{\Sigma m}$, etc.

Now, if instead of a system of stray particles, we get a continuous body, we may consider it to be formed of an infinite number of infinitely small elements of masses, and in this case it may be shown, as in the other cases *viz.*, determination of lengths, areas, etc., the summation Σ will be replaced by the integral sign.

Thus, if δm be an element of mass of the body at a point whose co-ordinates are x, y (or in three dimensions, x, y, z) the position of the centre of mass of the body will be given by

$$\bar{x} = \frac{\int x \, dm}{\int dm}, \quad \bar{y} = \frac{\int y \, dm}{\int dm},$$

the limits of integration being such as to include the whole body.

In practice, the elementary mass δm is proportional to the element of length δs , or element of area, or element of volume of the corresponding element, according as we proceed to find the centroid of an arc, or area or solid, and the limits of integration will then be the limits of the corresponding element.

12'1(1). Illustrative Examples.

Ex. 1. Find the centroid of an wire in the form of a circular arc.

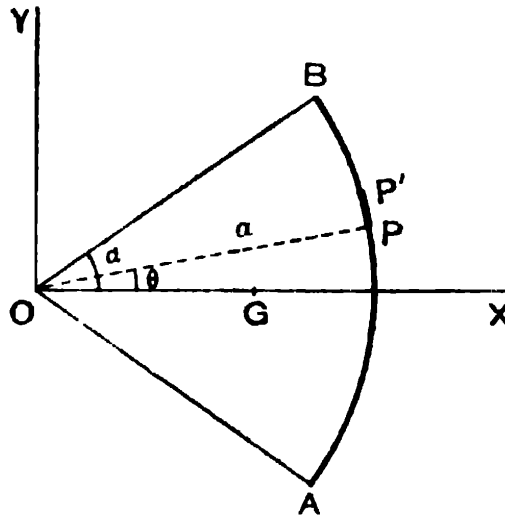

Let AB be a wire in the form of circular arc of radius ' a ', which subtends an angle 2α at its centre O .

Take O as origin, and OX , which bisects the arc AB , as the x -axis.

Then by symmetry, the centroid G lies somewhere on OX .

Now, θ denoting the vectorial angle of the point P on the arc, the element PP' there has a length $a d\theta$, and the abscissa of P is $a \cos \theta$. Also, to cover the whole arc, θ extends between the limits $-\alpha$ to α . Hence, the abscissa OG of the centroid G is given by

$$\bar{x} = \frac{\int x dm}{\int dm} = \frac{\int_{-\alpha}^{\alpha} a \cos \theta \cdot \rho a d\theta}{\int_{-\alpha}^{\alpha} \rho a d\theta}$$

(ρ denoting the linear density of the wire)

$$= a \frac{\int_{-a}^a \cos \theta \, d\theta}{\int_{-a}^a d\theta} = a \frac{2 \sin a}{2a} = a \frac{\sin a}{a}.$$

Cor. The distance of the *centroid* of a semi-circular arc from the centre is $\frac{2a}{\pi}$.

Ex. 2. Find the centre of gravity of a uniform lamina bounded by a parabola and a double ordinate of it.

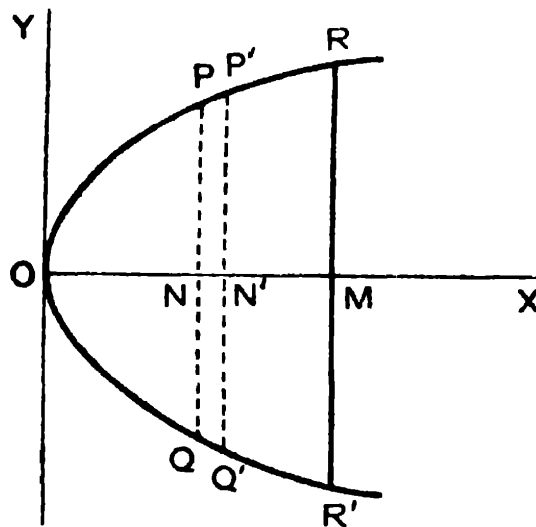

Let the lamina be bounded by a parabola $y^2 = 4ax$ and a double ordinate $RM'R'$ given by $x = x_1$.

By symmetry, the centroid lies on the x -axis, and hence $\bar{y} = 0$.

Divide the lamina into elementary strips by lines parallel to the y -axis. Consider the strip $PQQ'P'$, where the co-ordinates of P are (x, y) . The length PQ is $2y$ and the breadth NN' is δx . Hence, the area of the strip is ultimately $2y \delta x$. The limits of x , to cover the area considered, are clearly 0 to x_1 .

Hence, for the required centre of gravity,

$$\bar{x} = \frac{\int x \, dm}{\int dm} = \frac{\int_0^{x_1} x \cdot 2y \, dx \cdot \sigma}{\int_0^{x_1} 2y \, dx \cdot \sigma}$$

(where σ is the surface-density of the lamina)

$$\frac{\int_0^{x_1} x \cdot 2\sqrt{4ax} dx \cdot \sigma}{\int_0^{x_1} 2\sqrt{4ax} dx \cdot \sigma} = \frac{\int_0^{x_1} x^{\frac{3}{2}} dx}{\int_0^{x_1} x^{\frac{1}{2}} dx} = \frac{\frac{2}{5}x_1^{\frac{5}{2}}}{\frac{2}{3}x_1^{\frac{3}{2}}} = \frac{3}{5}x_1.$$

Thus, the centre of gravity divides the length OM in the ratio of 3 : 2.

Ex. 3. Find the centre of gravity of a uniform lamina in the form of a quadrant of the ellipse $\frac{x^2}{a^2} + \frac{y^2}{b^2} = 1$. [P. P. 1935]

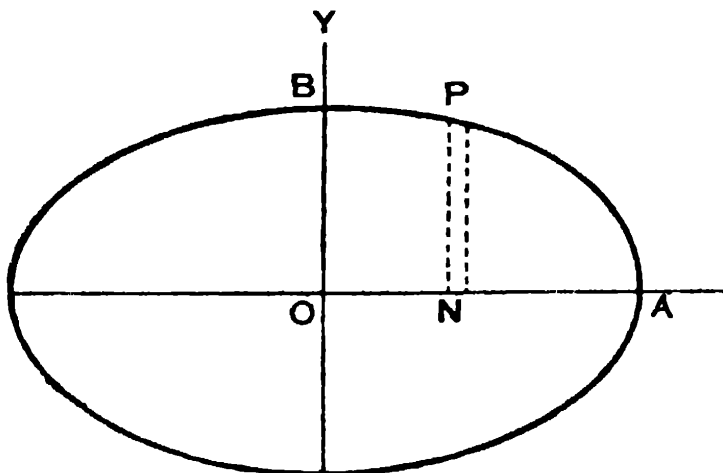

Let AOB be the quadrant considered. Divide it into elementary strips by lines parallel to the y -axis. The area of the elementary strip corresponding to the point P , whose co-ordinates are x, y , is ultimately $y \delta x$, and the centroid of this element is at the middle point of the strip (which is supposed infinitely thin) and thus has its co-ordinates $x, \frac{y}{2}$. The limits of x for the quadrant considered are evidently 0 and a .

Hence, the C.G. of the area considered will be given by (x', y') denoting the co-ordinates of the centroid of the element dm which is taken here as the strip),

$$\frac{\int x' dm}{\int dm} = \frac{\int_0^a x \cdot y dx \cdot \sigma}{\int_0^a y dx \cdot \sigma} \quad [\sigma \text{ being the surface-density of the lamina }]$$

$$\begin{aligned}
 &= \frac{\int_0^a x \cdot \frac{b}{a} \sqrt{a^2 - x^2} dx \cdot \sigma}{\int_0^a \frac{b}{a} \sqrt{a^2 - x^2} dx \cdot \sigma} \left[\because x^2 + y^2 = a^2 \right] \\
 &= \frac{\int_0^a x \sqrt{a^2 - x^2} dx}{\int_0^a \sqrt{a^2 - x^2} dx} = a \cdot \frac{\int_0^{\frac{1}{2}\pi} \sin \theta \cos^2 \theta d\theta}{\int_0^{\frac{1}{2}\pi} \cos^2 \theta d\theta} \\
 & \hspace{15em} [\text{ putting } x = a \sin \theta]
 \end{aligned}$$

$$\frac{1}{2} \cdot \frac{\frac{1}{3} \pi - \frac{4a}{3\pi}}{\frac{1}{2} \cdot \frac{\pi}{2}}$$

$$\begin{aligned}
 \bar{y} &= \frac{\int y' dm}{\int dm} = \frac{\int_0^a \frac{y}{2} \cdot y dx \cdot \sigma}{\int_0^a y dx \cdot \sigma} = \frac{1}{2} \cdot \frac{\int_0^a \frac{b^2}{a^2} (a^2 - x^2) dx}{\int_0^a \frac{b}{a} \sqrt{a^2 - x^2} dx} \\
 &= \frac{1}{2} b \frac{\int_0^{\frac{1}{2}\pi} \cos^3 \theta d\theta}{\int_0^{\frac{1}{2}\pi} \cos^2 \theta d\theta} = \frac{1}{2} b \frac{\frac{2}{3}}{\frac{1}{2} \cdot \frac{\pi}{2}} = \frac{4b}{3\pi}
 \end{aligned}$$

Cor. The centroid of half the ellipse bounded by the minor axis is on the major axis at a distance $\frac{4a}{3\pi}$ from the centre.

Also the centroid of a semi-circular area of radius 'a' is on the radius bisecting it, at a distance $\frac{4a}{3\pi}$ from the centre.

Ex. 4. Find the centre of gravity of a solid hemisphere.

Clearly, the hemisphere may be supposed to be generated by revolving a circular quadrant *APB* about one bounding radius *OA*, which we may choose as the *x*-axis. By symmetry, the centre of gravity of the hemisphere will be on *OX*. Now, divide the hemisphere into infinitely thin circular slices by planes perpendicular to the axis of revolution *OX*. An element of such slice, corresponding to the point *P*,

has its volume ultimately equal to $\pi y^2 \delta x$ (x, y being the cartesian co-ordinates of P), and the x -co-ordinates of its centre is x .

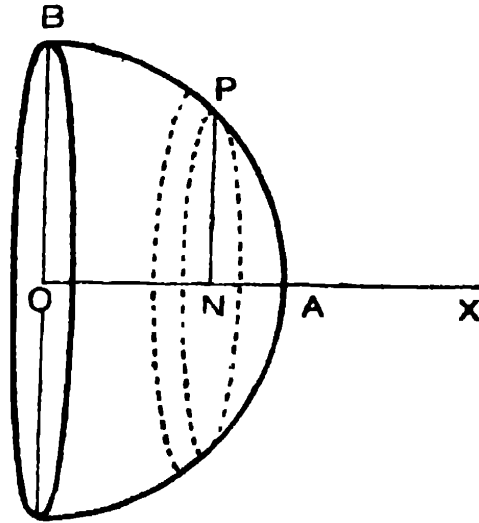

Hence, if ρ be the density of the solid hemisphere and a its radius, the position of the C. G. is given by

$$= \frac{\int_0^a x \cdot \pi y^2 dx \cdot \rho}{\int_0^a \pi y^2 dx \cdot \rho} = \frac{\int_0^a x(a^2 - x^2) dx}{\int_0^a (a^2 - x^2) dx} \quad [\because x^2 + y^2 = a^2]$$

$$\frac{a^2 \cdot \frac{a^2}{2} - \frac{a^4}{4}}{a^2 \cdot a - \frac{a^3}{3}} = \frac{3}{8} a.$$

12.2. Moment of Inertia.

If a system of particles have masses m_1, m_2, m_3, \dots and if r_1, r_2, r_3, \dots be their distances from a given line, then $\sum mr^2$ is defined as the *moment of inertia* of the system of particles about the given line.

If M be the total mass of the system m_1, m_2, \dots , it is usual to express the moment of inertia of the system about any line in the form Mk^2 , where k represents a length

and is called the radius of gyration of the system about the given line.

If instead of a system of particles, it is a body in the form of a thin wire, or a lamina or a solid, of which we want to find the moment of inertia about a given line, we may consider the body to be made up of an infinite number of infinitely small elements of masses, and then the summation $\sum mr^2$ reduces to the integral $\int r^2 \, dm$, where the limits are such as to cover the whole body.

12·2(1). Illustrative Examples.

Ex. 1. Find the moment of inertia of a thin uniform straight rod of mass M and length $2a$ about its perpendicular bisector.

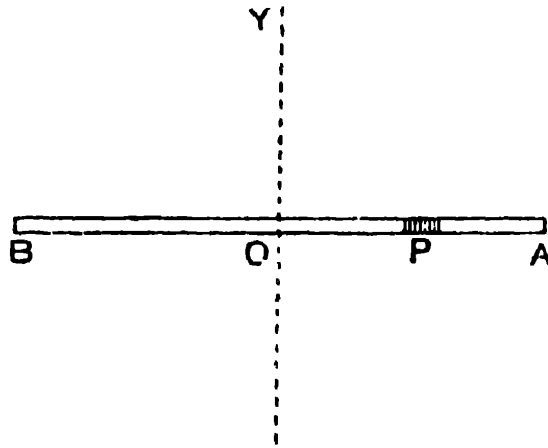

An infinitesimal element of length δx at P whose distance from the middle point of the rod is x , has its mass $\frac{M}{2a} \delta x$. Hence, the moment of inertia of the rod about the perpendicular bisector OY is given by

$$= \int_{-a}^{+a} x^2 \cdot \frac{M}{2a} dx = \frac{M}{2a} \cdot \frac{2a^3}{3} = M \frac{a^2}{3}.$$

Ex. 2. Find the moment of inertia of a thin uniform lamina in the form of a rectangle about an axis of symmetry through its centre.

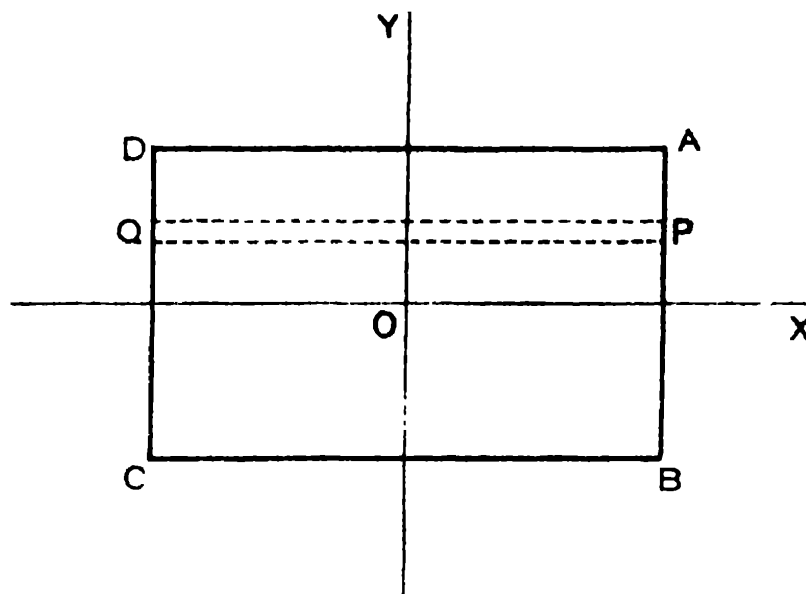

Let $2a$ and $2b$ be the lengths of the adjacent sides AD and AB of the rectangular lamina $ABCD$, and OX , OY the axes of symmetry through its centre O , which are parallel to them.

M being the mass of the lamina, the surface-density is clearly $\frac{M}{4ab}$. Now, divide the lamina into thin strips parallel to OX , and consider any strip PQ at a distance y from OX , whose breadth is δy . The mass of the strip is then evidently $\frac{M}{4ab} \cdot 2a \delta y$. Every portion of it being ultimately at the same distance y from OX , the moment of inertia of the whole lamina about the x -axis is given by

$$I_x = \int_{-b}^{+b} y^2 \cdot \frac{M}{4ab} 2a dy$$

$$= M \frac{b^3}{3}$$

Similarly, the moment of inertia of the lamina about OY is given by

$$I_y = M \frac{a^3}{3}$$

Ex. 3. Find the moment of inertia of a thin uniform elliptic lamina about its axes.

Let $\frac{x^2}{a^2} + \frac{y^2}{b^2} = 1$ be the equation to the ellipse. Its area is known to be πab , and if M be its mass, the surface-density is $\frac{M}{\pi ab}$. Dividing the lamina into thin strips by lines parallel to the x -axis, an elementary strip at a distance y from the x -axis has its length $2x = 2\frac{a}{b} \sqrt{b^2 - y^2}$ from the equation of the elliptic boundary. Thus, δy being the breadth of the strip, its mass is $\frac{M}{\pi ab} \cdot 2\frac{a}{b} \sqrt{b^2 - y^2} \delta y$.

Hence, the moment of inertia of the lamina about the x -axis is given by

$$\begin{aligned} I_x &= \int_{-b}^{+b} y^2 \cdot \frac{M}{\pi ab} \cdot 2\frac{a}{b} \sqrt{b^2 - y^2} dy \\ &= \frac{2Mb^2}{\pi} \int_{-\frac{1}{2}\pi}^{+\frac{1}{2}\pi} \sin^2\theta \cos^2\theta d\theta \quad [\text{putting } y = b \sin \theta] \\ &= \frac{2Mb^2}{\pi} \frac{\pi}{8} = M \frac{b^2}{4}. \end{aligned}$$

Similarly, the moment of inertia of the lamina about the y -axis is given by

$$I_y = M \frac{a^2}{4}.$$

Cor. The moment of inertia of a thin uniform circular disc of mass M , and radius a , about any diameter is $M \frac{a^2}{4}$. [P. P. 1932]

Ex. 4. Find the moment of inertia of a thin uniform circular plate about an axis through its centre perpendicular to its plane.

Let M be the mass and a the radius of the circular lamina, so that its surface-density is $\frac{M}{\pi a^2}$.

Divide the lamina into infinitely thin concentric rings by circles concentric with the boundary. Any elementary ring between circles

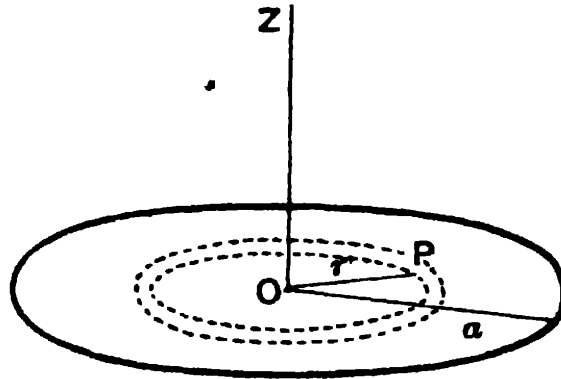

of radii r and $r + \delta r$ has its area ultimately equal to $2\pi r \delta r$ and so its mass is $\frac{M}{\pi a^2} \cdot 2\pi r \delta r$. As every part of the ring is ultimately at the same distance r from the axis in question which is perpendicular to its plane through the centre, the moment of inertia of the ring about the axis is ultimately $\frac{M}{\pi a^2} \cdot 2\pi r \delta r \cdot r^2$.

Hence, the required moment of inertia of the disc about the axis is given by

$$I = \int_0^a \frac{M}{\pi a^2} 2\pi r dr \cdot r^2$$

$$= \frac{2M}{a^2} \int_0^a r^3 dr = \frac{2M}{a^2} \cdot \frac{a^4}{4} = M \frac{a^2}{2}$$

Ex. 5. Find the moment of inertia of a sphere about a diameter.

[P. P. 1934]

If M be the mass and a the radius of the sphere, the volume of the sphere is known to be $\frac{4}{3}\pi a^3$, and hence its density is $\frac{M}{\frac{4}{3}\pi a^3}$.

Take the diameter about which the moment of inertia is required to be the x -axis. Divide the sphere into infinitely thin circular slices by planes perpendicular to this axis. An elementary slice between the planes x and $x + \delta x$ has its volume ultimately equal to $\pi (a^2 - x^2) \delta x$,

since its radius is $\sqrt{a^2 - x^2}$. [See *Fig. Ex. 4, Art. 12'1*] Hence, the moment of inertia of this slice about the x -axis, which is perpendicular to its plane through its centre, is ultimately

$$\frac{M}{\frac{4}{3}\pi a^3} \cdot \pi (a^2 - x^2) \delta x \cdot \frac{a^2 - x^2}{2}. \quad [\text{ See } Ex. 4 \text{ above }]$$

Hence, the required moment of inertia of the whole sphere about the diameter is given by

$$\begin{aligned} I &= \int_{-a}^{+a} \frac{M}{\frac{4}{3}\pi a^3} \cdot \pi (a^2 - x^2) dx \cdot \frac{a^2 - x^2}{2} \\ &= \frac{3}{8} \frac{M}{a^3} \int_{-a}^{+a} (a^4 - 2a^2 x^2 + x^4) dx \\ &= \frac{3}{8} \frac{M}{a^3} \left(a^4 \cdot 2a - 2a^2 \cdot \frac{2a^3}{3} + \frac{2a^5}{5} \right) = \frac{2}{5} Ma^2. \end{aligned}$$

EXAMPLES XII

1. Show that the C. G. of thin hemispherical shell is at the middle point of the radius perpendicular to its bounding plane.

2. Show that the C. G. of (i) a solid right circular cone is on the axis at a distance from the base equal to $\frac{1}{4}$ of the height of the cone ; (ii) a thin hollow cone without base is on the axis at a distance from the base equal to $\frac{1}{3}$ of the height of the cone.

3. Find the centroid of the whole arc of the cardioid $r = a(1 + \cos \theta)$.

4. Find the centroid of the area bounded by the cycloid $x = a(\theta + \sin \theta)$, $y = a(1 - \cos \theta)$ and its base.

5. Find the centroid of the sector of a circle.

[*P. P. 1931*]

6. Find the centroid of the arc of the parabola $y^2 = 4ax$ included between the vertex and one extremity of the latus rectum.

7. Find the positions of the centroids of the following areas :

(i) A loop of the curve $y^2(a+x) = x^2(a-x)$.

(ii) Area bounded by the curve $y^2(2a-x) = x^3$, and its asymptote.

(iii) Area bounded by $y^2 = 4ax$ and $y = 2x$.

(iv) One loop of $r = a \cos 2\theta$.

8. Find the moment of inertia of a solid right circular cylinder of radius a about its axis. [*P. P. 1933*]

9. Obtain the moment of inertia of a solid right circular cone of height h and semi-vertical angle α about its axis.

10. Prove that the moment of inertia about an axis through the centre perpendicular to the plane of a thin circular ring whose outer and inner radii are a and b is $\frac{1}{2}M(a^2 + b^2)$, where M denotes the mass of the ring.

11. Find the moment of inertia of a rectangular parallelepiped, the lengths of whose edges are respectively $2a$, $2b$, $2c$, about an axis through its centre parallel to the edge $2a$.

12. Show that the moment of inertia of a thin hollow spherical shell of radius a and mass M , about a diameter is $M \frac{2a^2}{3}$.

13. Show that the moment of inertia of a parabolic area of latus rectum $4a$, cut off by an ordinate of a distance h from the vertex, is $\frac{3}{7}Mh^2$ about the tangent at the vertex, and $\frac{4}{5}Mah$ about the axis, M being the mass of the area.

14. Show that if a thin lamina has its moments of inertia about two perpendicular axes in its plane respectively equal to I_1 and I_2 , then the moment of inertia about a normal to the plane through their point of intersection is $I_1 + I_2$.

15. Prove the *theorem of parallel axes* in case of a lamina, namely, that the moment of inertia of a thin lamina about any given line in its plane is equal to that about a parallel line through its C. G., together with the moment of inertia of the whole mass concentrated at the C. G. about the given line.

ANSWERS

3. $x = \frac{1}{2}a, y = 0.$

4. $x = 0, y = \frac{1}{3}a.$

5. On the radius bisecting the sector, at a distance $\frac{2}{3}a \frac{\sin a}{a}$ from the centre, $2a$ being the angle of the sector at the centre, and a the radius.

6. $x = \frac{a}{4} \cdot \frac{3\sqrt{2} - \log(\sqrt{2} + 1)}{\sqrt{2} + \log(\sqrt{2} + 1)}, y = \frac{4a}{3} \cdot \frac{2\sqrt{2} - 1}{\sqrt{2} + \log(\sqrt{2} + 1)}$

7. (i) $x = \frac{a}{3} \cdot \frac{3\pi - 8}{4 - \pi}, y = 0.$

(ii) $x = \frac{5a}{3}, y = 0.$

(iii) $x = \frac{2}{3}a, y = a.$

(iv) $x = \frac{128\sqrt{2}}{105} \cdot \frac{a}{\pi}, y = 0.$

8. $M \frac{a^2}{2}.$

9. $\frac{3}{10} Mh^2 \tan^2 a.$

11. $M \frac{b^2 + c^2}{3}.$

CHAPTER XIII
ON SOME WELL-KNOWN CURVES

13·1. We give below diagrams, equations, and a few characteristics of some well-known curves which have been used in the preceding pages in obtaining their properties. The student is supposed to be familiar with conic sections and graphs of circular functions, so they are not given here.

13·2. **Cycloid.**

The *cycloid* is the curve traced out by a point on the circumference of a circle which rolls (without sliding) on a straight line.

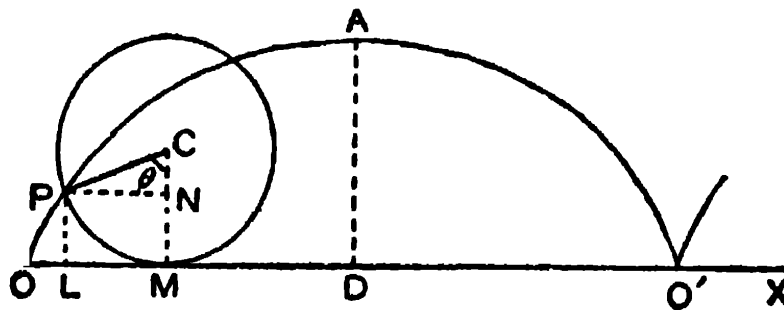

Fig. (i)

$$x = a(\theta - \sin \theta).$$

$$y = a(1 - \cos \theta).$$

Let P be the point on the circle MP , called the *generating circle*, which traces out the cycloid. Let the line OMX on which the circle rolls be taken as x -axis and the point O on OX , with which P was in contact when the circle began rolling, be taken as the origin.

Let a be the radius of the generating circle, and C its centre, P the point (x, y) on it, and let $\angle PCM = \theta$. Then

θ is the angle through which the circle turns as the point P traces out the locus.

$$\therefore OM = \text{arc } PM = a\theta.$$

Let PL be drawn perpendicular to OX .

$$\begin{aligned} \therefore x = OL = OM - LM &= a\theta - PN = a\theta - a \sin \theta \\ &= a(\theta - \sin \theta). \end{aligned}$$

$$\begin{aligned} y = PL = NM = CM - CN &= a - a \cos \theta \\ &= a(1 - \cos \theta). \end{aligned}$$

Thus, the parametric equations of the cycloid with the starting point as the origin and the line on which the circle rolls, called the base, as the x -axis, are

$$x = a(\theta - \sin \theta), \quad y = a(1 - \cos \theta). \quad \dots \quad (i)$$

The point A at the greatest distance from the base OX is called the *vertex*. Thus, for the vertex, y i.e., $a(1 - \cos \theta)$ is maximum. Hence, $\cos \theta = -1$ i.e., $\theta = \pi$.

$$\therefore AD = a(1 - \cos \pi) = 2a. \quad \therefore \text{vertex is } (a\pi, 2a).$$

For O and O' , $y = 0$. $\therefore \cos \theta = 1$. $\therefore \theta = 0$ and 2π .

As the circle rolls on, arches like OAO' are generated over and over again, and any single arch is called a cycloid.

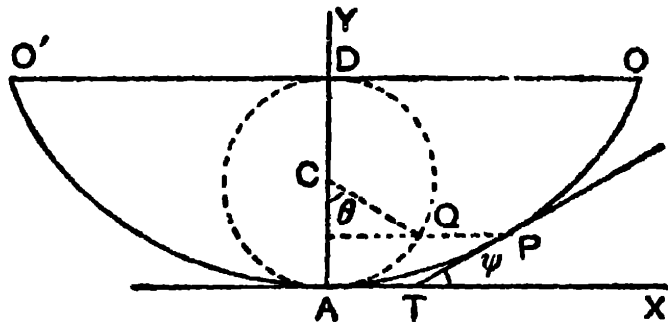

Fig. (ii)

$$x = a(\theta + \sin \theta). \quad y = a(1 - \cos \theta).$$

Since the vertex is the point $(a\pi, 2a)$ the equation of the cycloid with the vertex as the origin and the tangent

at the vertex as the x -axis can be obtained from the previous equation by transferring the origin to $(a\pi, 2a)$ and turning the axes through π i.e., by writing

$$a\pi + x' \cos \pi - y' \sin \pi \quad \text{and} \quad 2a + x' \sin \pi + y' \cos \pi$$

for x and y respectively.

$$\text{Hence, } a(\theta - \sin \theta) = a\pi - x',$$

$$\text{or, } x' = a(\pi - \theta) + a \sin \theta = a(\theta' + \sin \theta'),$$

$$\text{where } \theta' = \pi - \theta,$$

$$\text{and } a(1 - \cos \theta) = 2a - y',$$

$$\text{or, } y' = 2a - a + a \cos \theta = a + a \cos \theta$$

$$= a - a \cos (\pi - \theta) = a(1 - \cos \theta').$$

Hence, (dropping dashes) the equation of the cycloid with the vertex as the origin and the tangent at the vertex as the x -axis is

$$x = a(\theta + \sin \theta), \quad y = a(1 - \cos \theta). \quad \dots \quad (\text{ii})$$

In this equation, $\theta = 0$ for the vertex, $\theta = \pi$ for O , and $\theta = -\pi$ for O' .

The characteristic properties are :

(i) For the cycloid $x = a(\theta - \sin \theta)$, $y = a(1 - \cos \theta)$, radius of curvature = twice the length of the normal.

(ii) The evolute of the cycloid is an equal cycloid.

(iii) For the cycloid $x = a(\theta + \sin \theta)$, $y = a(1 - \cos \theta)$, $\psi = \frac{1}{2}\theta$ and $s^2 = 8ay$, s being measured from the vertex.

(iv) The length of the above cycloid included between the two cusps is $8a$.

(v) Intrinsic equation is $s = 4a \sin \psi$.

Note. The above equation (ii) can also be obtained from the Fig. (i) geometrically as follows :

If (x', y') be the co-ordinates of P referred to the vertex as the origin and the tangent at the vertex as the x -axis,

$$x' = LD = OD - OL = a\pi - x = a(\pi - \theta) + a \sin \theta,$$

$$y' = AD - PL = 2a - y = 2a - a(1 - \cos \theta) = a(1 + \cos \theta).$$

Hence, writing θ' (or θ) for $\pi - \theta$, etc.

13.3. Catenary.

The *catenary* is the curve in which a uniform heavy string will hang under the action of gravity when suspended from two points. It is also called the *chainette*.

Its equation, as shown in books on Statics, is

$$y = c \cosh \frac{x}{c} = \frac{c}{2} (e^{\frac{x}{c}} + e^{-\frac{x}{c}}).$$

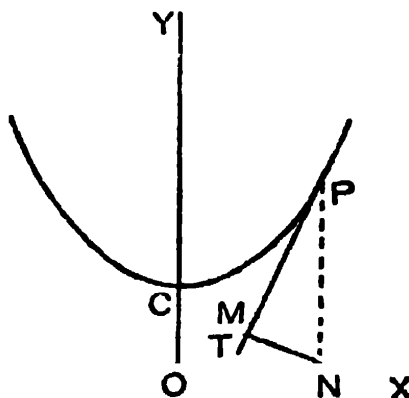

C is called the *vertex*; $OC = c$. OX is called the *directrix*.

The *characteristic properties* are :

(i) The perpendicular from the foot of the ordinate upon the tangent at any point is of constant length.

(ii) Radius of curvature at any point = length of the normal at the point (the centre of curvature and the x -axis being on the opposite sides of the curve).

(iii) $y^2 = c^2 + s^2$, s being measured from the vertex C .

(iv) $s = c \tan \psi$, $y = c \sec \psi$.

(v) $x = c \log (\sec \psi + \tan \psi)$.

13'4. Tractrix.

Its equation is

$$x = \sqrt{a^2 - y^2} + \frac{a}{2} \log \frac{a - \sqrt{a^2 - y^2}}{a + \sqrt{a^2 - y^2}},$$

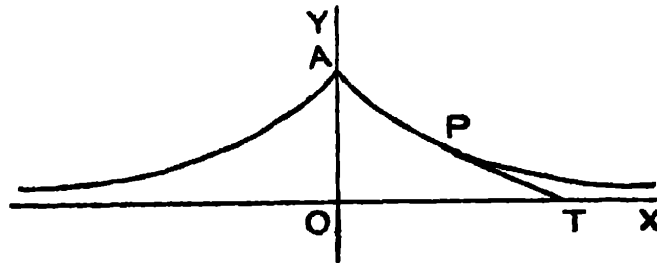

$$\text{or, } x = a(\cos t + \log \tan \frac{1}{2}t), y = a \sin t.$$

Here, $OA = a$.

The *characteristic properties* are :

(i) The portion of the tangent intercepted between the curve and the x -axis, is constant.

(ii) The radius of curvature varies inversely as the normal (the centre of curvature and the x -axis being on the opposite sides of the curve).

(iii) The evolute of the tractrix is the catenary

$$y = a \cosh (x/a).$$

13'5. Astroid.

Its equation is $x^{\frac{2}{3}} + y^{\frac{2}{3}} = a^{\frac{2}{3}}$,

$$\text{or, } x = a \cos^3 \theta, y = a \sin^3 \theta.$$

Here, $OA = OB = OA' = OB' = a$.

The whole figure lies completely within a circle of radius a and centre O . The points A, A', B, B' are called cusps. It is a special type of a four-cusped hypo-cycloid.

[See § 13'6]

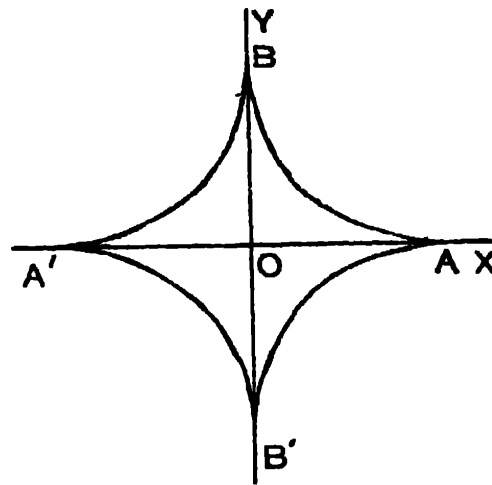

The *characteristic property* of this curve is that the tangent at any point to the curve intercepted between the axes is of constant length.

The perimeter of the astroid $x^{\frac{2}{3}} + y^{\frac{2}{3}} = a^{\frac{2}{3}}$ is $6a$.

13.6. Four-cusped Hypo-cycloid.

Its equation is $\left(\frac{x}{a}\right)^{\frac{2}{3}} + \left(\frac{y}{b}\right)^{\frac{2}{3}} = 1$,

or, $x = a \cos^3 \phi, y = b \sin^3 \phi$.

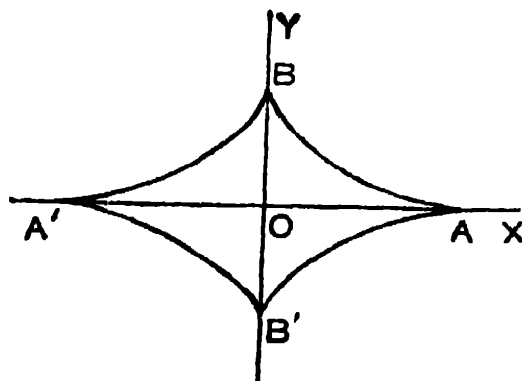

Here, $OA = OA' = a; OB = OB' = b$.

The perimeter of the hypo-cycloid $ABA'B'$ is $4 \frac{a^2 + ab + b^2}{a + b}$.

The astroid is a special case of this when $a = b$.

13.7. Evolutes of Parabola and Ellipse.

(i) The evolute of the parabola $y^2 = 4ax$ is

$$27ay^2 = 4(x - 2a)^3.$$

This curve is called a *semi-cubical parabola*.

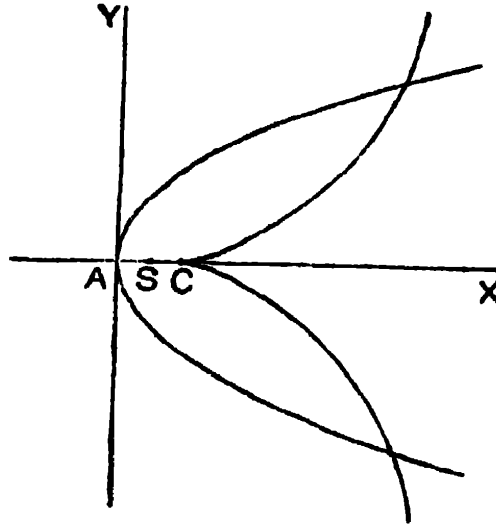

Transferring the origin to $(2a, 0)$, its equation assumes the form $y^2 = kx^3$ where $k = 4/27a$, which is the standard equation of the semi-cubical parabola with its vertex at the origin.

Hence, the vertex C of the evolute is $(2a, 0)$.

(ii) The equation of the evolute of the ellipse

$$x^2/a^2 + y^2/b^2 = 1 \text{ is}$$

$$(ax)^{\frac{2}{3}} + (by)^{\frac{2}{3}} = (a^2 - b^2)^{\frac{2}{3}},$$

which can be written in the form

$$\left(\frac{x}{a}\right)^{\frac{2}{3}} + \left(\frac{y}{\beta}\right)^{\frac{2}{3}} = 1,$$

where $\alpha = (a^2 - b^2)/a$, $\beta = (a^2 - b^2)/b$.

The area of the evolute is $\frac{3}{8}\pi \frac{(a^2 - b^2)^2}{ab}$.

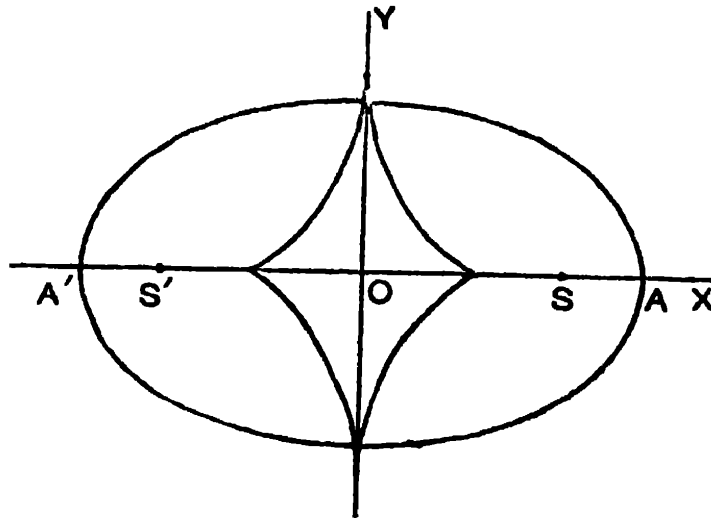

The length of the evolute is $4\left(\frac{a^2}{b} - \frac{b^2}{a}\right)$.

Hence, it is a four-cusped hypo-cycloid.

13·8. Folium of Descartes.

Its equation is $x^3 + y^3 = 3axy$.

It is symmetrical about the line $y = x$.

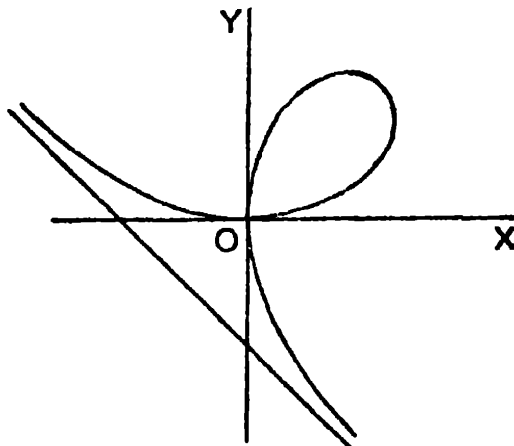

The axes of co-ordinates are tangents at the origin, and there is a loop in the first quadrant.

It has an asymptote $x + y + a = 0$ and its radii of curvature at origin are each $= \frac{3}{2}a$.

The area included between the curve and its asymptote
 = the area of the loop of the curve
 = $\frac{8}{3}a^2$.

13'9. Logarithmic and Exponential Curves.

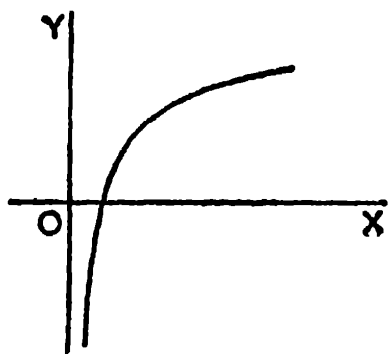

(i) $y = \log x$.

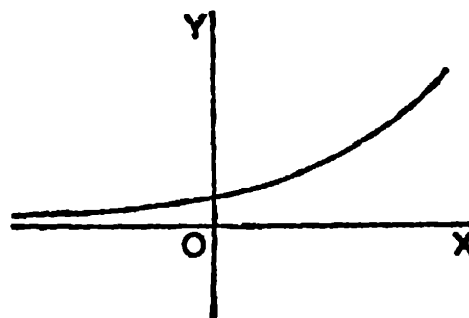

(ii) $y = e^x$.

(i) x is always positive ; $y=0$ when $x=1$, and as x becomes smaller and smaller, y , being negative, becomes numerically larger and larger. For $x > 0$, the curve is continuous.

(ii) x may be positive or negative but y is always positive and y becomes smaller and smaller, as x , being negative, becomes numerically larger and larger. The curve is continuous for all values of x .

13'10. Probability Curve.

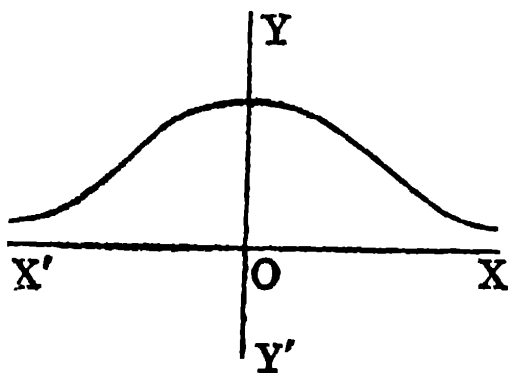

The equation of the probability curve is $y = e^{-x^2}$.

The x -axis is an asymptote.

The area between the curve and the asymptote is

$$= 2 \int_0^{\infty} e^{-x^2} dx = 2 \cdot \frac{1}{2} \sqrt{\pi} = \sqrt{\pi}.$$

13.11. Cissoid of Diocles.

Its cartesian equation is

$$y^2 (2a - x) = x^3.$$

$OA = 2a$; $x = 2a$ is an asymptote.

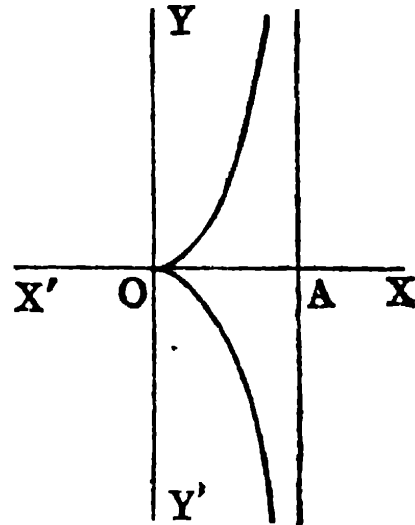

Its polar equation is

$$r = \frac{2a \sin^2 \theta}{\cos \theta}.$$

13.12. Strophoid.

The equation of the curve is

$$y^2 = x^3 \cdot \frac{a+x}{a-x}.$$

$$OA = OB = a.$$

$OCBPO$ is a loop.

$x = a$ is an asymptote.

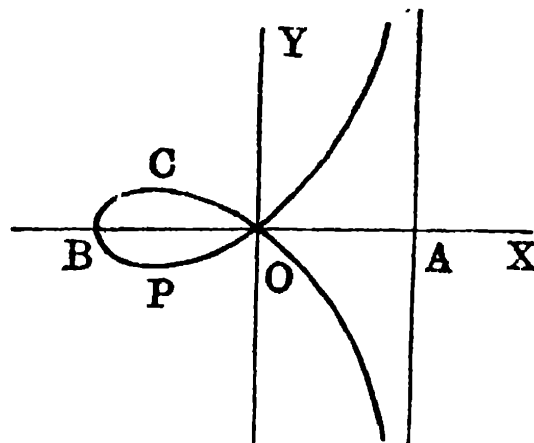

The curve $y^2 = x^3 \frac{a-x}{a+x}$ is similar, just the reverse of

strophoid, the loop being on the right side of the origin and the asymptote on the left side.

13·13. Witch of Agnesi.

The equation of the curve is

$$xy^2 = 4a^2(2a - x).$$

Here, $OA = 2a$.

This curve was first discussed by the Italian lady mathematician Maria Gaetana Agnesi, Professor of Mathematics at Bologna.

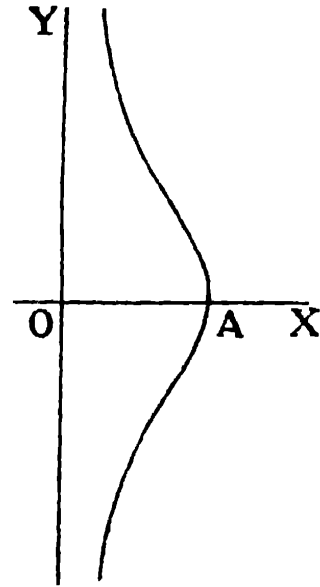

13·14. Logarithmic (or Equiangular) spiral.

Its equation is $r = ae^{\theta \cot \alpha}$ (or, $r = ae^{m\theta}$),

where $\cot \alpha$ or m is constant.

Characteristic Properties :

(i) The tangent at any point makes a constant angle with the radius vector, ($\phi = \alpha$).

(ii) Its pedal, inverse, polar reciprocal and evolute are all equiangular spirals.

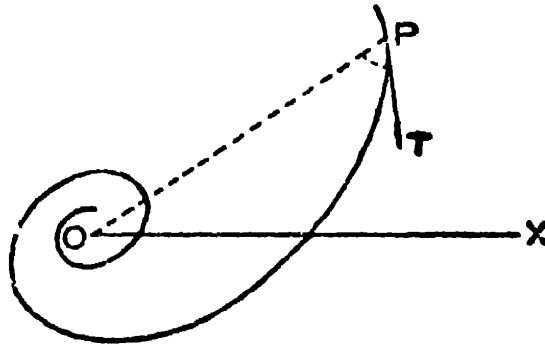

(iii) The radius of curvature subtends a right angle at the pole.

Note. Because of the property (i), the spiral is called *equiangular*.

13·15. Spiral of Archimedes.

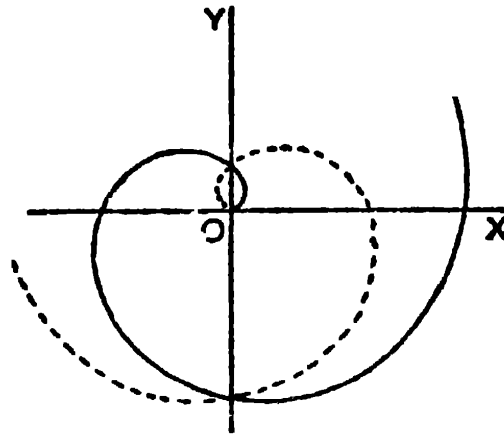

Its equation is $r = a\theta$.

Its *characteristic property* is that its polar subnormal is constant.

13·16. Cardioide.

Its equation is (i) $r = a(1 + \cos \theta)$, or, (ii) $r = a(1 - \cos \theta)$.

In (i), $\theta = 0$ for A , and $\theta = \pi$ for O .

In (ii), $\theta = \pi$ for A , and $\theta = 0$ for O .

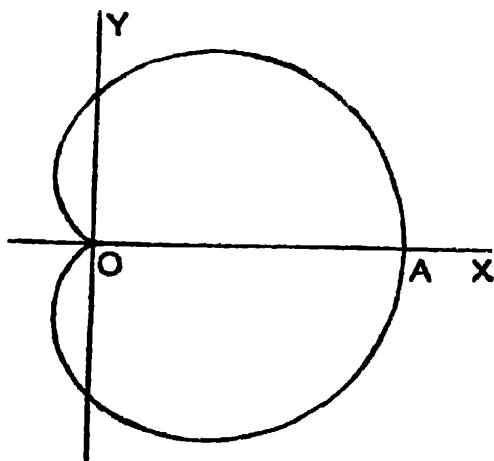

(i) $r = a(1 + \cos \theta)$.

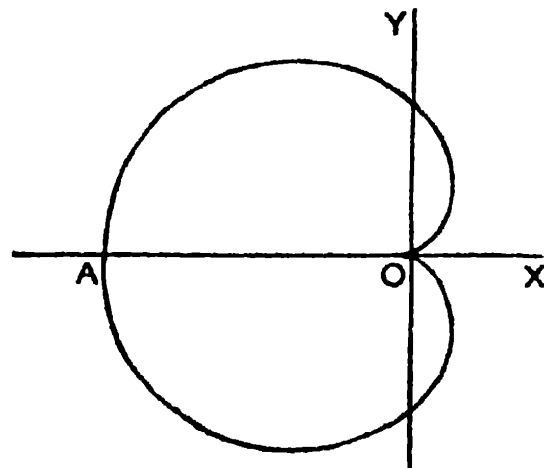

(ii) $r = a(1 - \cos \theta)$.

In both cases, the curve is symmetrical about the initial line, which divides the whole curve into two equal halves, and for the upper half, θ varies from 0 to π , and $OA = 2a$.

The curve (ii) is really the same as (i) turned through 180° .

The curve passes through the origin, its tangent there being the initial line, and the tangent at A is perpendicular to the initial line.

The evolute of the cardioid is a cardioid.

The perimeter of the cardioid is $8a$.

Note. Because of its shape like human heart, it is called a cardioid. The cardioid $r = a(1 + \cos \theta)$ is the pedal of the circle $r = 2a \cos \theta$ with respect to a point on the circumference of the circle, and inverse of the parabola $r = a/(1 + \cos \theta)$.

13·17. Limacon.

The equation of the curve is

$$r = a + b \cos \theta.$$

When $a > b$, we have the outer curve, and when $a < b$, we have the inner curve with the loop.

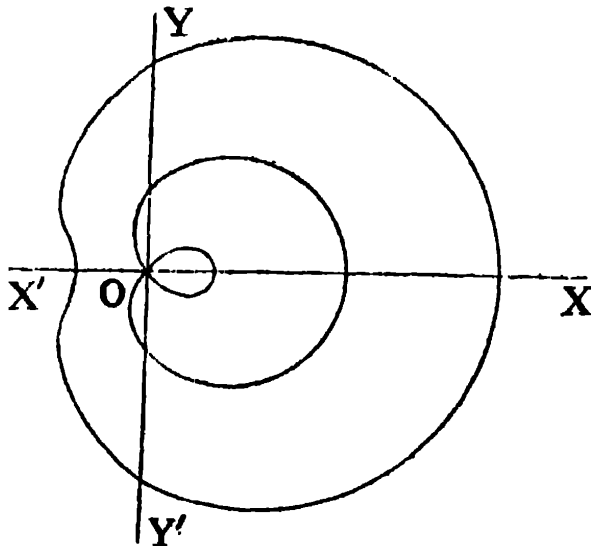

When $a = b$, the curve reduces to a cardioid.

[See fig. in § 13·16]

Limacon is the pedal of a circle with respect to a point outside the circumference of the circle.

13·18. Lemniscate.

Its equation is $r^2 = a^2 \cos 2\theta$,

$$\text{or, } (x^2 + y^2)^2 = a^2 (x^2 - y^2).$$

It consists of two equal loops, each symmetrical about the initial line, which divides each loop into two equal halves,

$$OA = OA' = a.$$

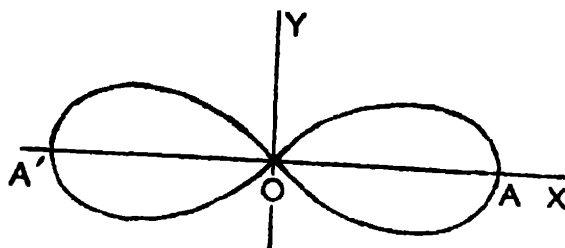

$$r^2 = a^2 \cos 2\theta$$

The tangents at the origin are $y = \pm x$.

For the upper half of the right-hand loop, θ varies from 0 to $\frac{1}{4}\pi$.

A characteristic property of it is that the product of the distances of any point on it from $(\pm a/\sqrt{2}, 0)$ is constant.

The area of the lemniscate is a^2 .

The lemniscate is the pedal of the rectangular hyperbola $r^2 \cos 2\theta = a^2$. The curve represented by $r^2 = a^2 \sin 2\theta$ is

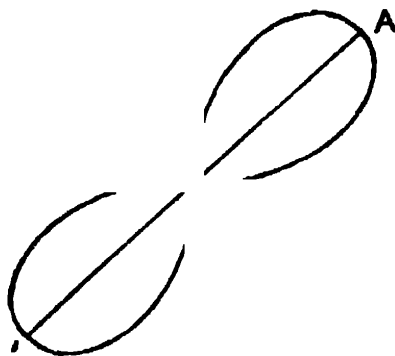

$$r^2 = a^2 \sin 2\theta$$

also sometimes called lemniscate or *rose lemniscate*, to distinguish it from the first lemniscate, which is sometimes called *Lemniscate of Bernoulli* after the name of the mathematician J. Bernoulli who first studied its properties.

The curve consists of two equal loops, situated in the first and third quadrants, and symmetrical about the line $y=x$. It is the first curve turned through 45° .

The tangents at the origin are the axes of x and y .

The area of the curve is a^2 .

13.19. Rose-Petals ($r = a \sin n\theta$, $r = a \cos n\theta$).

The curve represented by $r = a \sin 3\theta$, or, $r = a \cos 3\theta$ is called a *three-leaved rose*, each consisting of three equal

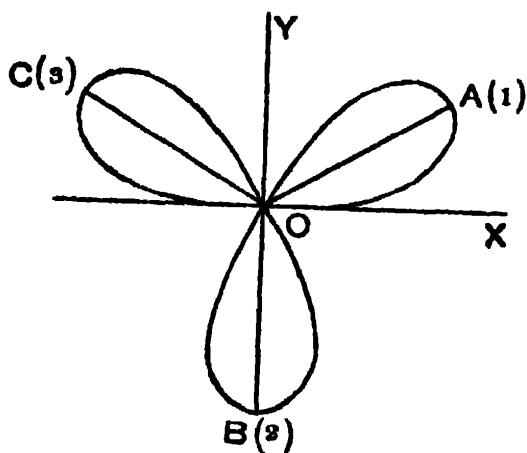

$$r = a \sin 3\theta$$

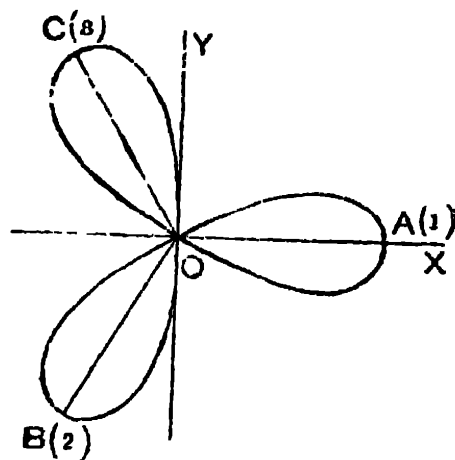

$$r = a \cos 3\theta$$

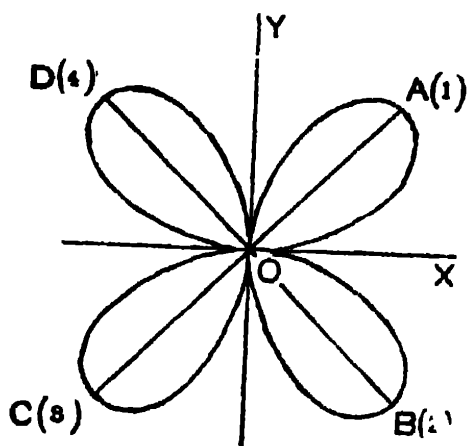

$$r = a \sin 2\theta$$

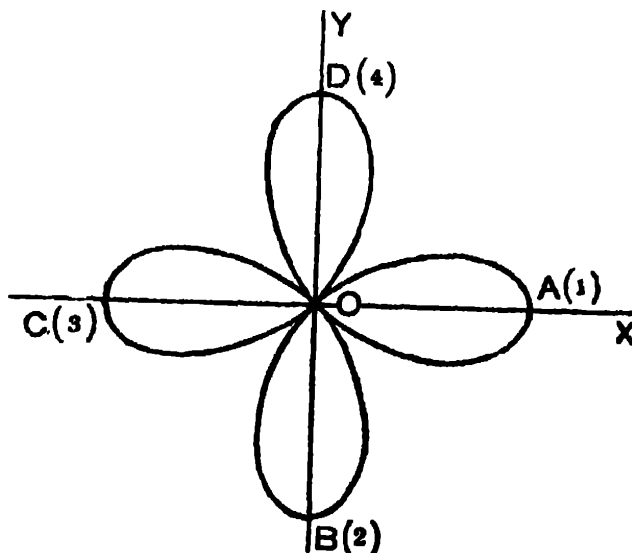

$$r = a \cos 2\theta$$

loops. The order in which the loops are described is indicated in the figures by numbers. In each case, $OA = OB = OC = a$, and $\angle AOB = \angle BOC = \angle COA = 120^\circ$.

The curve represented by $r = a \sin 2\theta$, or, $r = a \cos 2\theta$ is called a *four-leaved rose*, each consisting of four equal loops. In each case, $OA = OB = OC = OD = a$ and $\angle AOB = \angle BOC = \angle COD = \angle DOA = 90^\circ$.

The class of curves represented by $r = a \sin n\theta$, or, $r = a \cos n\theta$ where n is a positive integer is called *rose-petal*, there being n or $2n$ equal loops according as n is *odd* or *even*, all being arranged symmetrically about the origin and lying entirely within a circle whose centre is the pole and radius a .

13.20. Sine Spiral ($r^n = a^n \sin n\theta$ or $r^n = a^n \cos n\theta$).

The class of curves represented by (i) $r^n = a^n \sin n\theta$, or, (ii) $r^n = a^n \cos n\theta$ is called *sine spiral* and embraces several important and well-known curves as particular cases.

Thus, for the values $n = -1, 1, -2, +2, -\frac{1}{2}$ and $\frac{1}{2}$, the sine spiral is respectively a straight line, a circle, a rectangular hyperbola, a lemniscate, a parabola and a cardioid.

For (i) $\phi = n\theta$; for (ii) $\phi = \frac{1}{2}\pi + n\theta$.

The pedal equation in both the cases is

$$p = r^{n+1}/a^n.$$

DIFFERENTIAL EQUATIONS

CHAPTER XIV

INTRODUCTION AND DEFINITIONS

14.1. Definitions and classification.

A *differential equation* is an equation involving differentials (or differential coefficients) with or without the variables from which these differentials (or differential coefficients) are derived.

The following are examples of differential equations :

$$\frac{dy}{dx} = e^x \quad \dots \quad \dots \quad (1)$$

$$\left(\frac{dy}{dx}\right)^2 = ax^2 + bx + c \quad \dots \quad \dots \quad (2)$$

$$\frac{d^2y}{dx^2} = 0 \quad \dots \quad \dots \quad (3)$$

$$\left(\frac{d^3y}{dx^3}\right)^2 = x^2 \frac{dy}{dx} \quad \dots \quad \dots \quad (4)$$

$$\frac{d^2y}{dx^2} + 5\left(\frac{dy}{dx}\right)^2 + 2y = 0 \quad \dots \quad \dots \quad (5)$$

$$x \frac{\delta z}{\delta x} + \frac{\delta z}{\delta y} = 0 \quad \dots \quad \dots \quad (6)$$

$$\frac{\delta^2 u}{\delta x^2} + \frac{\delta^2 u}{\delta y^2} = 0 \quad \dots \quad \dots \quad (7)$$

Differential equations are divided into two classes *viz.*, *Ordinary* and *Partial*.

An *ordinary differential equation* is one in which all the differentials (or derivatives) involved have reference to a single independent variable.

A *partial differential equation* is one which contains partial differentials (or derivatives) and as such involves two or more independent variables.

Thus in the above set, equations (1), (2), (3), (4) and (5) are ordinary differential equations and equations (6) and (7) are partial differential equations.

In order to facilitate discussions, differential equations are classified according to order and degree.

The *order* of a differential equation is the order of the highest derivative (or differential) in the equation. Thus, equations (1) and (2) are of the first order, (3) and (5) are of the second order and (4) is of the third order.

The *degree* of an algebraic differential equation is the degree of the derivative (or differential) of the highest order in the equation, after the equation is freed from radicals and fractions in its derivatives. Thus, the equations (2) and (4) are of the second degree.

Note. Strictly speaking, the term 'degree' is used with reference to those differential equations only which can be written as polynomials in the derivatives.

We shall consider in this treatise only ordinary differential equations of different orders and degrees.

14.2. Formation of ordinary Differential Equations.

Let $f(x, y, c_1) = 0$ (1)

be an equation containing x, y and one arbitrary constant c_1 .

Differentiating (1), we get

$$\frac{\delta f}{\delta x} + \frac{\delta f}{\delta y} \cdot \frac{dy}{dx} = 0. \quad \dots \quad \dots \quad (2)$$

Equation (2) will in general contain c_1 . If c_1 be eliminated between (1) and (2), we shall get a relation involving x , y , and $\frac{dy}{dx}$, which will evidently be a differential equation of the first order.

Similarly, if we have an equation

$$f(x, y, c_1, c_2) = 0 \quad \dots \quad \dots \quad (3)$$

containing two arbitrary constants c_1 and c_2 , then by differentiating this twice, we shall get two equations. Now, between these two equations and the given equation, in all three equations, if the two arbitrary constants c_1 and c_2 be eliminated, we shall evidently get a differential equation of the second order.

In general, if we have an equation

$$f(x, y, c_1, c_2, \dots, c_n) = 0 \quad \dots \quad \dots \quad (4)$$

containing n arbitrary constants c_1, c_2, \dots, c_n , then by differentiating this n times, we shall get n equations. Now, between these n equations and the given equation, in all $(n+1)$ equations, if the n arbitrary constants c_1, c_2, \dots, c_n be eliminated, we shall evidently get a differential equation of the n th order*, for there being n differentiations, the resulting equation must contain a derivative of the n th order.

Note. From the process of forming a differential equation from a given primitive, it is clear that since the equation obtained by varying the arbitrary constants in the primitive represents a certain system or family of curves, the differential equation (in which the constants do not appear) expresses some property common to all those curves.

* A relation containing n arbitrary constants may in certain cases give rise to a differential equation of order less than n .

We may thus say that *a differential equation represents a family of curves all satisfying some common property*. This can be considered as the **geometrical interpretation** of the differential equation.

14'3. Solution of a Differential Equation.

Any relation connecting the variables of an equation and not involving their derivatives, which satisfies the given differential equation *i.e.*, from which the given differential equation can be derived, is called a *solution* of the differential equation. Thus,

$$y = e^x + C, \text{ where } C \text{ is any arbitrary constant,}$$

and $y = Ax + B$, where A and B are arbitrary constants, are respectively solutions of the differential equations (1) and (3) of Art. 14'1.

From the above, it is clear that a differential equation may have an unlimited number of solutions, for each of the different relations obtained by giving particular values to the arbitrary constant or constants in the solution of the equations satisfies the equation, and hence, is a solution to the equation; thus, $y = x - \sqrt{11}$, $y = 2x - 3$, $y = -\frac{5}{2}x$ etc. are all solutions of the differential equation (3) of Art. 14'1.

The arbitrary constants A, B, C appearing in the solution are called *arbitrary constants of integration*.

The solution of a differential equation in which the number of *independent arbitrary constants* is equal to the order of the equation, is called the *general* or *complete solution* (or *complete primitive*) of the equation.

The solution obtained by giving particular values to the arbitrary constants of the general solution, is called a *particular solution* of the equation.

Thus, $y = Ax + B$ is the general solution, and $y = x - \sqrt{11}$, $y = 2x - 3$, $y = -\frac{5}{2}x$ are all particular solutions of the equation (3) of Art. 14'1.

There is another kind of solution called the *singular solution*, which will be discussed in a subsequent chapter. [See Art. 16'4]

By a proper manipulation of the arbitrary constants in the general solution of a differential equation, the general solution is very often written in different forms ; it should be noted however that each of these forms determines the same relation between the variables. This will be subsequently illustrated in the worked out examples.

When an equation is to be solved, it is generally implied that the complete solution is required.

It sometimes happens that the process of solving a differential equation leads to integrals which cannot be evaluated in terms of known elementary functions. In such a case, the equation is considered as having been solved when it has been reduced to an expression involving integrals and it is said that the *solution of the equation has been reduced to quadrature*.

Note 1. The arbitrary constants in the solution of a differential equation are said to be *independent*, when it is impossible to deduce from the solution an equivalent relation containing fewer arbitrary constants. Thus, the two arbitrary constants A, B in the equation $y = Ae^{x+B}$ are not independent, since the equation can be written as $y = Ae^B \cdot e^x = Ce^x$.

Note 2. In the elementary treatise we shall not concern ourselves with the question whether a differential equation has a solution or what are the conditions under which it will have a solution

of a particular character ; in fact we shall assume without proof the following fundamental theorem of differential equations *viz.*,

An ordinary differential equation of order n has a solution involving n independent arbitrary constants, and this solution is unique.

14'3(1). Illustrative Examples.

Ex. 1. Find the differential equation of all straight lines passing through the origin.

$$\text{Let } y = mx \quad \dots \quad \dots \quad (1)$$

be the equation of any straight line passing through the origin.

$$\text{Differentiating (1), } \frac{dy}{dx} = m. \quad \dots \quad (2)$$

Eliminating m between (1) and (2), we get

$$y = x \frac{dy}{dx}, \text{ the required differential equation.}$$

Ex. 2. Find the differential equation from the relation

$$x = a \cos t + b \sin t,$$

a and b being arbitrary constants.

Differentiating the given relation twice with respect to t , we get

$$x_1 = -a \sin t + b \cos t, \quad \text{and}$$

$$x_2 = -a \cot t - b \sin t = -(a \cos t + b \sin t) = -x.$$

$\therefore x_2 + x = 0$, i.e., $\frac{d^2x}{dt^2} + x = 0$ is the required differential equation.

Ex. 3. Eliminate a and b from $y = a \tan^{-1}x + b$.

Differentiating the given relation with respect to x ,

$$y_1 = \frac{a}{1+x^2}. \quad \therefore (1+x^2)y_1 = a.$$

Differentiating, $(1+x^2)y_2 + 2xy_1 = 0$.

This is the required eliminant.

EXAMPLES XIV

1. Show that the differential equation of a system of concentric circles is $x dx + y dy = 0$. Interpret the result geometrically.

2. Prove that the differential equation of all circles touching the x -axis at the origin is $(x^2 - y^2) dy - 2xy dx = 0$.

3. (i) Show that the differential equation of all parabolas
 (a) having their axes parallel to y -axis is $y_3 = 0$.
 (b) with foci at the origin and axes along the x -axis is $yy_1^2 + 2xy_1 - y = 0$.
- (ii) Show that the differential equation of the family of circles $x^2 + y^2 + 2gx + 2fy + c = 0$ is $(1 + y_1^2)y_3 - 3y_1y_2^2 = 0$.
- (iii) Show that the differential equation of the family of cardioids $r = a(1 + \cos \theta)$ is $(1 + \cos \theta) dr + r \sin \theta d\theta = 0$.

4. Show that the differential equation of the system of rectangular hyperbolas $xy = c^2$ is $x dy + y dx = 0$, and interpret the result geometrically; deduce that the tangent intercepted between the axes is bisected at the point of contact.

5. Verify that $y + x + 1 = 0$ is a solution of the differential equation $(y - x) dy - (y^2 - x^2) dx = 0$.

6. Show that $V = \frac{A}{r} + B$ is a solution of the differential equation

$$\frac{d^2 V}{dr^2} + \frac{2}{r} \frac{dV}{dr} = 0.$$

7. Find the differential equation from the relation
 (i) $y = A \sin x + B \cos x + x \sin x$.
 (ii) $y = Ae^x + Be^{-x}$.
 (iii) $y = A \cos x + B \sin x + C \cosh x + D \sinh x$,
 where A, B, C, D are arbitrary constants.

8. Eliminate a and b from each of the relations

- (i) $y = a \log x + b$. (ii) $xy = ae^x + be^{-x}$.
 (iii) $ax^2 + by^2 = 1$. [C. P. 1945] (iv) $r = a + b \cos \theta$.

9. (i) Show that the differential equation, whose generally solution is $y = c_1 x + c_2 x^2$ is $y = xy_1 - \frac{1}{2}x^2 y_2$.

(ii) Show that

$$y = \cos x, \quad y = \sin x, \quad y = c_1 \cos x, \quad y = c_2 \sin x$$

are all solutions of the differential equation

$$y_2 + y = 0.$$

[In (i) and (ii) c_1, c_2 are arbitrary constants]

10. (i) Show that the differential equations, whose general solutions are

$$(i) \quad y = A \sin x + B \cos x,$$

$$(ii) \quad y = A \sinh x + B \cosh x,$$

where A and B are arbitrary constants, are respectively

$$\frac{d^2 y}{dx^2} + y = 0 \quad \text{and} \quad \frac{d^2 y}{dx^2} - y = 0.$$

ANSWERS

1. The radius vector and the tangent at any point are mutually perpendicular.

4. The radius vector and the tangent at any point are equally inclined to the x -axis.

$$7. (i) \quad y + y_2 = 2 \cos x. \quad (ii) \quad y_2 - y = 0. \quad (iii) \quad y_4 - y = 0.$$

$$8. (i) \quad xy_2 + y_1 = 0. \quad (ii) \quad xy_2 + 2y_1 = xy.$$

$$(iii) \quad x(yy_2 + y_1^2) = yy_1. \quad (iv) \quad r_2 = r_1 \cot \theta.$$

CHAPTER XV
EQUATIONS OF THE FIRST ORDER AND
THE FIRST DEGREE

15·1. A differential equation of the first order and first degree can be put in the form

$$M dx + N dy = 0,$$

where both M and N are functions of x and y , or constants not involving the derivatives. The general solution of an equation of this type contains only one arbitrary constant. In this chapter we shall consider only certain special types of equations of the first degree.

15·2. Separation of the Variables.

If the equation $M dx + N dy = 0$ can be put in the form

$$f_1(x) dx + f_2(y) dy = 0,$$

then it can be immediately solved by integrating each term separately. Thus, the solution of the above equation is

$$\int f_1(x) dx + \int f_2(y) dy = C.$$

The process of reducing the equation $M dx + N dy = 0$ to the form $f_1(x) dx + f_2(y) dy = 0$ is called the *Separation of the Variables*.

Note. Sometimes *transformation to the polar co-ordinates* facilitates separation of variables. In this connection it is convenient to remember the following differentials.

If $x = r \cos \theta$, $y = r \sin \theta$,

(i) $x dx + y dy = r dr$.

(ii) $dx^2 + dy^2 = dr^2 + r^2 d\theta^2$.

(iii) $x dy - y dx = r^2 d\theta$.

[For illustration see Ex. 8(ii) and (iii) of Examples XV(A)]

Ex. 1. Solve $(1+y^2) dx + (1+x^2) dy = 0$.

Dividing by $(1+x^2)(1+y^2)$, we get

$$\frac{dx}{1+x^2} + \frac{dy}{1+y^2} = 0.$$

\therefore integrating, $\tan^{-1}x + \tan^{-1}y = C$ (1)

Note. Writing the arbitrary constant C in the form $\tan^{-1}a$, the above solution can be written as $\tan^{-1}x + \tan^{-1}y = \tan^{-1}a$,

$$\text{or, } \tan^{-1} \frac{x+y}{1-xy} = \tan^{-1}a, \text{ or, } x+y = a(1-xy). \quad \dots (2)$$

Both forms of solution, (1) and (2), are perfectly general; and any one of these can be considered as the complete solution of the given equation. [See Art. 14'3]

Ex. 2. Solve $x(y^2+1) dx + y(x^2+1) dy = 0$.

Dividing both sides by $(x^2+1)(y^2+1)$, we have

$$\frac{x}{x^2+1} dx + \frac{y}{y^2+1} dy = 0.$$

\therefore integrating, we have

$$\frac{1}{2} \log(x^2+1) + \frac{1}{2} \log(y^2+1) = C.$$

Writing $\frac{1}{2} \log A$ in the place of C , the above solution can be written in the form

$$(x^2+1)(y^2+1) = A.$$

Note. In order to express the solution in a neat form, we have taken $\frac{1}{2} \log A$ (A being a constant) in the place of the arbitrary constant C .

Ex. 3. Solve $(x+y)^2 \frac{dy}{dx} = a^2$. [C. P. 1936]

Put $x+y=v$, i.e., $y=v-x$. $\therefore \frac{dy}{dx} = \frac{dv}{dx} - 1$.

\therefore the equation reduces to

$$v^2 \left(\frac{dv}{dx} - 1 \right) = a^2, \quad \text{or, } \frac{dv}{dx} = 1 + \frac{a^2}{v^2} = \frac{a^2+v^2}{v^2}.$$

$$\therefore dx = \frac{v^2}{a^2+v^2} dv = \left(1 - \frac{a^2}{a^2+v^2} \right) dv.$$

$$\therefore \text{integrating, } \int dx = \int dv - a^2 \int \frac{dv}{a^2 + v^2},$$

$$\text{or, } x + C = v - a^2 \cdot \frac{1}{a} \tan^{-1} \frac{v}{a} = x + y - a \tan^{-1} \frac{x+y}{a}.$$

$$\therefore y = a \tan^{-1} \frac{x+y}{a} + C, \text{ is the reqd. solution.}$$

Ex. 4. Find the foci of the curve which satisfies the differential equation $(1+y^2) dx - xy dy = 0$ and passes through the point $(1, 0)$.

Separating the variables of the equation, we have

$$\frac{dx}{x} - \frac{y dy}{1+y^2} = 0.$$

$$\therefore \text{integrating, } \log x - \frac{1}{2} \log(1+y^2) = \log C,$$

$$\text{or, } \log \frac{x}{\sqrt{1+y^2}} = \log C. \quad \therefore x = C \sqrt{1+y^2}.$$

This is the equation of any curve satisfying the given differential equation. If the curve passes through $(1, 0)$, we have $1 = C$,

$$\therefore \text{the equation of the required curve is } x^2 - y^2 = 1.$$

It is a rectangular hyperbola, and its foci are evidently $(\pm \sqrt{2}, 0)$.

Ex. 5. Show that all curves for which the length of the normal is equal to the radius vector are either circles or rectangular hyperbolas.

Since the length of the normal $= y \sqrt{1+y'^2}$ and the radius vector $= \sqrt{x^2 + y^2}$,

$$\therefore y^2(1+y_1'^2) = x^2 + y^2, \text{ or, } y^2 y_1'^2 = x^2 \text{ or, } yy_1' = \pm x.$$

$$\therefore \frac{dy}{dx} = \pm \frac{x}{y}. \quad \therefore x dx \pm y dy = 0.$$

\therefore integrating, $x^2 \pm y^2 = a^2$, a^2 being the arbitrary constant of integration.

Thus, the curves are either circles or rectangular hyperbolas.

Ex. 6. Show that by substituting $ax + by + c = z$, in the equation $\frac{dy}{dx} = f(ax + by + c)$ the variables can be separated.

$$\therefore ax + by + c = z, \quad \therefore a + b \frac{dy}{dx} = \frac{dz}{dx}.$$

$$\therefore \frac{dy}{dx} = \frac{1}{b} \left(\frac{dz}{dx} - a \right).$$

Hence the given equation transforms into

$$\frac{1}{b} \left(\frac{dz}{dx} - a \right) = f(z),$$

$$\text{i.e., } \frac{dz}{a + b f(z)} = dx.$$

Thus, the variables are separated.

EXAMPLES XV(A)

Solve the following differential equations (Ex. 1-10) :—

$$1. \quad (i) \quad \frac{dy}{dx} = \frac{x^2 + x + 1}{y^2 + y + 1}, \quad (ii) \quad x^2 \frac{dy}{dx} + y = 1.$$

$$(iii) \quad \frac{dy}{dx} + \frac{y(y-1)}{x(x-1)} = 0.$$

$$2. \quad (i) \quad y \, dx + (1 + x^2) \tan^{-1} x \, dy = 0.$$

$$(ii) \quad e^{x-y} \, dx + e^{y-x} \, dy = 0.$$

$$3. \quad (i) \quad x \sqrt{1-y^2} \, dx + y \sqrt{1-x^2} \, dy = 0.$$

$$(ii) \quad x^2 (y-1) \, dx + y^2 (x-1) \, dy = 0.$$

$$4. \quad \frac{dy}{dx} + \frac{y^2 + y + 1}{x^2 + x + 1} = 0.$$

$$5. \quad (i) \quad \frac{dy}{dx} + \sqrt{\frac{1-y^2}{1-x^2}} = 0, \quad (ii) \quad \frac{dy}{dx} = \frac{x(1+y^2)}{y(1+x^2)}.$$

$$(iii) \quad \frac{dy}{dx} + \frac{\sqrt{(x^2-1)(y^2-1)}}{xy} = 0.$$

$$6. \quad (i) \quad \sec^2 x \tan y \, dx + \sec^2 y \tan x \, dy = 0.$$

$$(ii) \quad x \cos^2 y \, dx - y \cos^2 x \, dy = 0.$$

$$(iii) \quad \log \frac{(\sec x + \tan x)}{\cos x} \, dx = \log \frac{(\sec y + \tan y)}{\cos y} \, dy.$$

$$7. \quad (x^2 - yx^2) \, dy + (y^2 + xy^2) \, dx = 0.$$

8. (i) $y \, dx - x \, dy = xy \, dx.$

(ii) $x^2(x \, dx + y \, dy) + 2y(x \, dy - y \, dx) = 0.$

(iii) $\frac{x + yy_1}{xy_1 - y} = \sqrt{\left(\frac{1 - x^2 - y^2}{x^2 + y^2}\right)}.$

9. (i) $\frac{dy}{dx} + 1 = e^{x+y}.$ (ii) $\frac{dy}{dx} = \sqrt{y-x}.$

10. (i) $\sin^{-1}\left(\frac{dy}{dx}\right) = x + y.$ (ii) $\log\left(\frac{dy}{dx}\right) = ax + by.$

11. Find the particular solution of

$$\cos y \, dx + (1 + 2e^{-x}) \sin y \, dy = 0,$$

when $x = 0, y = \frac{1}{4}\pi.$

12. Find the equation of the curve for which

(i) the cartesian subtangent is constant,

(ii) the cartesian subnormal is constant, [*C. P. 1924*]

(iii) the polar subtangent is constant, [*P. P. 1933*]

(iv) the polar subnormal is constant. [*P. P. 1931*]

13. Show that the curve for which the normal at every point passes through a fixed point is a circle.

14. Show that the curve for which the radius of curvature at every point is constant is a circle.

15. Show that the curve for which the tangent at every point makes a constant angle with the radius vector is an equi-angular spiral.

16. Show that the curve in which the angle between the tangent and the radius vector at every point is one-half of the vectorial angle, is a cardioid. [*C. P. 1931*]

17. Show that the curve in which the angle between the tangent and the radius vector at every point is one-third

of the inclination of the tangent to the initial line, is a cardioide.

18. Show that the curve in which the portion of the tangent included between the co-ordinate axes is bisected by the point of contact is a rectangular hyperbola.

ANSWERS

1. (i) $\frac{1}{2}(x^3 - y^3) + \frac{1}{2}(x^2 - y^2) + x - y = C$. (ii) $y = 1 + Ce^{1/r}$.
 (iii) $xy = c(x-1)(y-1)$. 2. (i) $y \tan^{-1} x = C$.
 (ii) $e^{2x} + e^{2y} = C$. 3. (i) $\sqrt{1-x^2} + \sqrt{1-y^2} = C$.
 (ii) $(x+1)^2 + (y+1)^2 + 2 \log(x-1)(y-1) = C$.
 4. $2xy + x + y + C(x+y+1) = 1$. 5. (i) $\sin^{-1} x + \sin^{-1} y = C$.
 (ii) $1 + y^2 = C(1 + x^2)$. (iii) $\sqrt{(x^2-1)} - \sec^{-1} x + \sqrt{(y^2-1)} = C$.
 6. (i) $\tan x \tan y = C$.
 (ii) $x \tan x - \log \sec x = y \tan y - \log \sec y + C$.
 (iii) $[\log(\sec x + \tan x)]^2 - [\log(\sec y + \tan y)]^2 = C$.
 7. $\log \frac{x}{y} - \frac{x+y}{xy} = C$. 8. (i) $ye^x = Cx$. (ii) $(x^2 + y^2)(x+2)^2 = Cx^2$.
 (iii) $x^2 + y^2 = \sin^2 a$, where $a = \tan^{-1}(y/x) + C$.
 9. (i) $e^y = \frac{1}{2}e^x + Ce^{-x}$. (ii) $\sqrt{y-x} + \log(\sqrt{y-x}-1) = \frac{1}{2}x + C$.
 10. (i) $\tan(x+y) - \sec(x+y) = C + x$. (ii) $ae^{-by} + be^{ax} = C$.
 11. $(e^x + 2) \sec y = 3\sqrt{2}$. 12. (i) $y = Ce^{x/a}$.
 (ii) $y^2 = 2ax + C$. (iii) $r(C - \theta) = a$. (iv) $r = a\theta + C$.

15.3. Homogeneous Equations.

If M and N of the equation $M dx + N dy = 0$ are both of the same degree in x and y , and are homogeneous, the equation is said to be *homogeneous*. Such an equation can be put in the form

$$\frac{dy}{dx} = f\left(\frac{y}{x}\right).$$

Every homogeneous equation of the above type can be easily solved by putting $y = vx$ where v is a function of x , and consequently $\frac{dy}{dx} = v + x \frac{dv}{dx}$, whereby it reduces to the form $v + x \frac{dv}{dx} = f(v)$ i.e., $\frac{dx}{x} = \frac{dv}{f(v) - v}$ in which the variables are separated.

Ex. Solve $(x^2 + y^2) dx - 2xy dy = 0$.

[C. P. 1921, '37

The equation can be written as

$$\frac{dy}{dx} = \frac{x^2 + y^2}{2xy}.$$

Putting $y = vx$, so that $\frac{dy}{dx} = v + x \frac{dv}{dx}$, we have,

$$v + x \frac{dv}{dx} = \frac{x^2 + v^2 x^2}{2vx^2} = \frac{1 + v^2}{2v}.$$

$$\therefore x \frac{dv}{dx} = \frac{1 + v^2}{2v} - v = \frac{1 - v^2}{2v}.$$

$$\therefore \frac{dx}{x} - \frac{2v}{1 - v^2} dv = 0.$$

\therefore integrating, $\log x + \log(1 - v^2) = \log C$.

$$\therefore x(1 - v^2) = C.$$

Re-substituting y/x for v and simplifying, we get the solution

$$x^2 - y^2 = Cx.$$

15.4. A special Form.

The equation of the form

$$\frac{dy}{dx} = \frac{a_1 x + b_1 y + c_1}{a_2 x + b_2 y + c_2} \quad \left(\frac{a_1}{a_2} \neq \frac{b_1}{b_2} \right) \quad \dots (1)$$

can be easily solved by putting $x = x' + h$, and $y = y' + k$, where h and k are constants, so that $dx = dx'$ and $dy = dy'$, and choosing h, k in such a way that

$$\text{and } \left. \begin{aligned} a_1 h + b_1 k + c_1 &= 0 \\ a_2 h + b_2 k + c_2 &= 0. \end{aligned} \right\} \quad \dots (2)$$

For, now the equation reduces to the form

$$\frac{dy'}{dx'} = \frac{a_1x' + b_1y'}{a_2x' + b_2y'}$$

which is homogeneous in x' and y' and hence solvable by the method of the previous article.

Note. The above method obviously fails, if $a_1/a_2 = b_1/b_2$; for in this case h and k cannot be determined from equation (2).

Let the equation be

$$\frac{dy}{dx} = \frac{a_1x + b_1y + c_1}{a_2x + b_2y + c_2} \quad \left(\frac{a_1}{a_2} = \frac{b_1}{b_2} \right) \quad (3)$$

Let $\frac{a_1}{a_2} = \frac{b_1}{b_2} = \frac{1}{m}$. $\therefore a_2 = a_1m, b_2 = b_1m,$

where m is a non-zero constant.

Assuming this to be the case, let the common value of these ratios be denoted by $1/m$, so that $a_2 = a_1m$ and $b_2 = b_1m$.

The equation (3) becomes

$$\frac{dy}{dx} = \frac{a_1x + b_1y + c_1}{m(a_1x + b_1y) + c_2}$$

Now, putting $a_1x + b_1y = v$, the variables can be easily separated and hence the equation can be solved. [See *Ex. 2, below.*]

Note. If in the equation (1), $a_2 = -b_1$, then the equation can be solved more easily by grouping the terms suitably.

[See *Examples XV(C), Ex. 1 (iv)*]

Ex. 1. Solve $\frac{dy}{dx} = \frac{6x - 2y - 7}{2x + 3y - 6}$. [C. P. 1934]

Putting $x = x' + h, y = y' + k$, so that $dx = dx', dy = dy'$, we have,

$$\frac{dy'}{dx'} = \frac{6x' - 2y' + 6h - 2k - 7}{2x' + 3y' + 2h + 3k - 6}$$

Putting $6h - 2k - 7 = 0$, and $2h + 3k - 6 = 0$,

and solving these two equations, we have $h = \frac{1}{2}, k = 1$.

\therefore the equation becomes $\frac{dy'}{dx'} = \frac{6x' - 2y'}{2x' + 3y'}$.

Since the equation is now homogeneous, putting $y' = vx'$ and hence, $\frac{dy'}{dx'} = v + x' \frac{dv}{dx'}$, and simplifying, the equation reduces to

$$\frac{dx'}{x'} = -\frac{1}{2} \frac{6v+4}{3v^2+4v-6} dv, \text{ which on integration gives,}$$

$$-\log Ax' = \frac{1}{2} \log (3v^2 + 4v - 6).$$

$$\therefore (Ax')^{-1} = (3v^2 + 4v - 6)^{\frac{1}{2}}.$$

Now, restoring the values of x' and v , where $x' = x - \frac{3}{2}$ and $v = \frac{y'}{x'} = \frac{2(y-1)}{2x-3}$, we get the solution in the form

$$3y^2 + 4xy - 6x^2 - 12y + 14x = C.$$

Ex. 2. Solve $\frac{dy}{dx} = \frac{6x-2y-7}{3x-y+4}$.

Since here $a_1/a_2 = b_1/b_2$, \therefore putting $3x - y = v$, we get

$$3 - \frac{dy}{dx} = \frac{dv}{dx}, \text{ and hence the given equation gives}$$

$$\frac{dv}{dx} = 3 - \frac{2v-7}{v+4} = \frac{v+19}{v+4}.$$

$$\therefore dx = \frac{v+4}{v+19} dv = \left(1 - \frac{15}{v+19}\right) dv.$$

$$\therefore x + C = v - 15 \log (v + 19).$$

On restoring the value of v , we get the solution in the form

$$2x - y - 15 \log (3x - y + 19) = C.$$

Ex. 3. Show that in an equation of the form

$$yf_1(xy) dx + xf_2(xy) dy = 0$$

the variables can be separated by the substitution $xy = v$.

Since, $xy = v$, $y = \frac{v}{x}$ and $d(xy) = dv$ i.e., $y dx + x dy = dv$

and $dy = \frac{x dv - v dx}{x^2}$ i.e., $x dy = dv - \frac{v}{x} dx$.

$$\therefore \frac{v}{x} f_1(v) dx + f_2(v) \left\{ dv - \frac{v}{x} dx \right\} = 0.$$

$$\therefore \frac{f_2(v) dv}{v\{f_1(v)-f_2(v)\}} + \frac{dx}{x} = 0.$$

Thus, the variables are separated.

[See *Ex. 14, 15, 16 of Examples XV(B)*]

We can as well form an equation in v and y , by taking $xy=v$,

$$x = \frac{v}{y} \text{ and } dx = \frac{y dv - v dy}{y^2}.$$

[For illustration see *Alternative proof of Ex. 5 of Art. 15.5.*]

EXAMPLES XV(B)

Solve :—

1. (i) $x + y \frac{dy}{dx} = 2y.$

(ii) $\frac{dy}{dx} + \frac{y}{x} = \frac{y^2}{x^2}.$

2. (i) $\frac{dy}{dx} = \frac{y(x-2y)}{x(x-3y)}.$

(ii) $\frac{dy}{dx} = \frac{x^2 y}{x^3 + y^3}.$

3. $(x^2 + y^2) dy = xy dx.$ [*C. P. 1925, '30*]

4. (i) $\frac{dy}{dx} = \frac{x-y}{x+y}.$

(ii) $\frac{dy}{dx} = \frac{y(y+x)}{x(y-x)}.$

5. (i) $(3x \sinh(y/x) + 5y \cosh(y/x)) dx - 5x \cosh(y/x) dy = 0.$

(ii) $(1 + 3e^{x/y}) dx + 3e^{x/y} (1 - x/y) dy = 0.$

6. $(x^2 - 2xy) dy + (x^2 - 3xy + 2y^2) dx = 0.$

7. $y^2 dx + (x^2 + xy) dy = 0.$

8. (i) $\frac{dy}{dx} = \frac{y}{x} + \tan \frac{y}{x}.$

(ii) $\frac{dy}{dx} = \frac{3x + 2y}{2x - 3y}.$

9. $(6x - 5y + 4) dy + (y - 2x - 1) dx = 0.$

10. $(x - 3y + 4) dy + (7y - 5x) dx = 0.$

11. $(2x - 2y + 5) dy - (x - y + 3) dx = 0.$

12. $(x + y + 1) dx - (2x + 2y + 1) dy = 0.$

13. $y(2xy + 1) dx + x(1 + 2xy + x^2 y^2) dy = 0.$

14. $x^2 y^3 dx + 3x^2 y dy + 2y dx = 0.$

15. $(1 + xy \cos xy) dx + x^2 \cos xy dy = 0.$

16. Show that $(4x + 3y + 1) dx + (3x + 2y + 1) dy = 0$ represents hyperbolas having as asymptotes
 $x + y = 0, 2x + y + 1 = 0.$

ANSWERS

1. (i) $y = x + Ce^{x/y-x}.$

(ii) $2x - y = Cx^2 y.$

2. (i) $y^3 e^{xy} = Cx^2.$

(ii) $y^3 = Ce^{x^3/y^3}.$

3. $y = Ce^{x^2/2y^2}.$

4. (i) $y^2 + 2xy - x^2 = C.$

(ii) $xy = Ce^{y/x}.$

5. (i) $x^3 = C \sinh^2(y/x).$

(ii) $x + 3ye^{xy} = C.$

6. $y = x \log(Cx^{-1}).$

7. $xy^2 = C(x + 2y).$

8. (i) $x = C \sin \frac{y}{x}.$

(ii) $3 \log(x^2 + y^2) = 4 \tan^{-1} \frac{y}{x} + C.$

9. $(5y - 2x - 3)^4 = C(4y - 4x - 3).$

10. $(3y - 5x + 10)^2 = C(y - x + 1).$

11. $2y - x + C = \log(x - y + 2).$

12. $6y - 3x = \log(3x + 3y + 2) + C.$

13. $2x^2 y^2 \log y - 4xy - 1 = Cx^2 y^2.$

14. $x(xy - 2)^3 = C(xy - 1)^3.$

15. $x e^{\sin xy} = C.$

15.5. Exact Equations.

The differential equation $M dx + N dy = 0$, where both M and N are functions of x and y , is said to be *exact* when there is a function u of x, y , such that $M dx + N dy = du$, i.e., when $M dx + N dy$ becomes a *perfect differential*.

Now, we know from Differential Calculus that $M dx + N dy$ should be a perfect differential if $\frac{\delta M}{\delta y} = \frac{\delta N}{\delta x}$. Hence, the condition that $M dx + N dy = 0$ should be an exact differential

equation, is

$$\frac{\delta M}{\delta y} = \frac{\delta N}{\delta x}.$$

Note. It is beyond the scope of the present treatise to enter into the details of the theory of singular solutions.

Ex. 1. Solve $y = px + p - p^2$. [C. P. 1936]

Differentiating both sides with respect to x ,

$$p = p + x \frac{dp}{dx} + \frac{dp}{dx} - 2p \frac{dp}{dx}$$

$$\frac{dx}{dx} (x + 1 - 2p) = 0.$$

$$\therefore \text{ either, } \frac{dp}{dx} = 0, \text{ i.e., } p = C \quad \dots (1)$$

$$\text{or, } x + 1 - 2p = 0, \text{ i.e., } p = \frac{1}{2}(x + 1). \quad \dots (2)$$

Eliminating p between (1) and the given equation, we get

$$y = Cx + C - C^2 \text{ as the complete solution}$$

and eliminating p between (2) and the given equation, we get

$$y = \frac{1}{2}(x + 1)x + \frac{1}{2}(x + 1) - \frac{1}{4}(x + 1)^2 = \frac{1}{4}(x + 1)^2,$$

i.e., $4y = (x + 1)^2$, as the singular solution.

Note. It can easily be verified that the family of straight lines represented by the complete solution touches the parabola represented by the singular solution.

Ex. 2. Solve $y = (1 + p)x + ap^2$.

Differentiating with respect to x , we have

$$p = (1 + p) + (x + 2ap) \frac{dp}{dx}$$

$$\therefore \frac{dx}{dp} + x = -2ap.$$

This is a linear equation in x and p . [See Art. 15·6]

\therefore multiplying both sides by $e^{\int dp}$ i.e., e^p , we get

$$e^p \frac{dx}{dp} + e^p \cdot x = -2ap \cdot e^p,$$

$$\text{or, } \frac{d}{dp} (xe^p) = -2ap \cdot e^p.$$

\therefore integrating, $xe^p = -2a \int pe^p dp + C = -2ae^p (p-1) + C,$

or, $x = 2a(1-p) + Ce^{-p}.$

$\therefore y = 2a - ap^2 + (1+p) Ce^{-p}$ from the given equation.

The p -eliminant of these two constitutes the solution.

EXAMPLES XVI

Solve the following and find the singular solutions of Ex. 5 to 8 only :—

1. (i) $p^2 + p - 6 = 0.$ (ii) $p^2 + 2xp - 3x^2 = 0.$
2. (i) $p^2 - p(e^x + e^{-x}) + 1 = 0.$
(ii) $p^2 y - p(xy + 1) + x = 0.$ (iii) $p(p^2 + xy) = p^2(x + y).$
3. (i) $p^2 - (a + b)p + ab = 0.$ (ii) $p(p + x) = y(x + y).$
4. (i) $xy p^2 - (x^2 - y^2)p - xy = 0.$
(ii) $p^3 - p(x^2 + xy + y^2) + x^2 y + xy^2 = 0.$
(iii) $p^3 - (x^2 + xy + y^2)p^2 + (x^3 y + x^2 y^2 + xy^3)p - x^3 y^3 = 0.$
5. (i) $y = px + a/p.$ (ii) $y = px + \sqrt{a^2 p^2 + b^2}.$
(iii) $y = px + p^n.$
6. (i) $y = px + ap(1 - p).$ (ii) $py = p^2(x - b) + a.$
7. $(x - a)p^3 + (x - y)p - y = 0.$
8. $(y + 1)p - xp^2 + 2 = 0.$
9. (i) $p^3 x - p^2 y - 1 = 0.$ (ii) $y = yp^2 + 2px.$ [C. P. 1948]
10. $\sin y \cos px - \cos y \sin px - p = 0.$
11. (i) $x = 4p + 4p^3.$ (ii) $p^2 - 2xp + 1 = 0.$
12. (i) $e^y - p^3 - p = 0.$ (ii) $y = p \cos p - \sin p.$
13. (i) $y = p^2 x + p.$ (ii) $y = (p + p^2)x + p^{-1}.$
14. (i) $x + yp = ap^2.$ (ii) $y = 2px + p^2.$
15. $p^3 - p(y + 3) + x = 0.$
16. $y = Ap^3 + Bp^2.$

ANSWERS

1. (i) $(y + 3x - c)(y - 2x - c) = 0$. (ii) $(2y + 3x^2 - c)(2y - x^2 - c) = 0$.
2. (i) $(y - e^x - c)(y + e^{-x} - c) = 0$. (ii) $(2y - x^2 - c)(2x - y^2 - c) = 0$.
- (iii) $(y - c)(2y - x^2 - c)(y - ce^x) = 0$ 3. (i) $(y - ax - c)(y - bx - c) = 0$.
- (ii) $(y - ce^x)(y + x - ce^{-x} - 1) = 0$. 4. (i) $(xy - c)(x^2 - y^2 - c) = 0$.
- (ii) $(2y - x^2 - c)(y - ce^x)(y + x - 1 - ce^{-x}) = 0$.
- (iii) $(x^3 - 3y + c)(c^{\frac{1}{2}}x^2 + cy)(xy + cy + 1) = 0$.
5. (i) $y = cx + \frac{a}{c}$; $y^2 = 4ax$. (ii) $y = cx + \sqrt{(a^2c^2 + b^2)}$; $\frac{x^2}{a^2} + \frac{y^2}{b^2} = 1$.
- (iii) $y = cx + c^n$; $n^n y^{n-1} + x^n(n-1)^{n-1} = 0$.
6. (i) $y = cx + ac(1 - c)$; $(x + a)^2 = 4ay$.
- (ii) $cy = c^2(x - b) + a$; $y^2 = 4a(x - b)$.
7. $(x - a)c^2 + (x - y)c - y = 0$; $(x + y)^2 = 4ay$.
8. $(y + 1)c - c^2x + 2 = 0$; $(y + 1)^2 + 8x = 0$.
9. (i) $c^3x - c^2y - 1 = 0$. (ii) $y^2 = 2cx + c^2$. 10. $y = cx + \sin^{-1}c$.
11. (i) $\left. \begin{aligned} x &= 4p + 4p^3 \\ y &= 2p^2 + 3p^4 + c \end{aligned} \right\}$ (ii) $\left. \begin{aligned} x &= \frac{1}{2}(p + p^{-1}), \\ y &= \frac{1}{2}p^2 - \frac{1}{2}\log p + c \end{aligned} \right\}$
12. (i) $\left. \begin{aligned} x &= 2 \tan^{-1}p - p^{-1} + c \\ y &= \log(p^3 + p) \end{aligned} \right\}$ (ii) $\left. \begin{aligned} x &= c + \cos p \\ y &= p \cos p - \sin p \end{aligned} \right\}$
13. (i) $\left. \begin{aligned} y &= p^2x + p \\ x &= \frac{\log p - p + c}{(p - 1)^2} \end{aligned} \right\}$ (ii) $\left. \begin{aligned} y &= (p + p^2)x + p^{-1} \\ x &= \frac{1 + ce^{\frac{1}{p}}}{p^2} \end{aligned} \right\}$
14. (i) $x + yp = ap^2$
 $x(1 + p^2)^{\frac{1}{2}} = p [c + a \log \{p + (1 + p^2)^{\frac{1}{2}}\}]$.
- (ii) $(3xy + 2x^3 + c)^2 - 4(x^2 + y)^3 = 0$.
15. $y(1 - p^2)^{\frac{1}{2}} + (1 - p^2)^{\frac{3}{2}} = c$, with the given relation.
16. $y = Ap^3 + Bp^2$
 $x = \frac{2}{3}Ap^2 + 2Bp + c$.
-

CHAPTER XVII
LINEAR EQUATIONS WITH CONSTANT
COEFFICIENTS

17.1. Equations of the Second Order.

We shall first consider linear differential equations with constant coefficients of the second order, since they occur very frequently in many branches of applied mathematics. The typical form of such equation is

$$\frac{d^2y}{dx^2} + P_1 \frac{dy}{dx} + P_2 y = X, \quad \dots \quad (1)$$

or, symbolically, $(D^2 + P_1 D + P_2) y = X$,

where P_1, P_2 are constants and X is a function of x only or a constant. Two forms of this equation usually present themselves, namely when the right-hand member is zero, and when the right-hand member is a function of x . We shall first consider the first form and then the second.

17.2. Equations with right-hand member zero.

Let the equation be

$$\frac{d^2y}{dx^2} + P_1 \frac{dy}{dx} + P_2 y = 0. \quad \dots \quad (2)$$

As a *trial solution** of (2), let us take $y = e^{mx}$. Then if we put $y = e^{mx}$ in the left side of (2), it must satisfy the equation; *i.e.*; we must have,

$$(m^2 + P_1 m + P_2) e^{mx} = 0,$$

or, since $e^{mx} \neq 0$, $m^2 + P_1 m + P_2 = 0. \quad \dots \quad (3)$

*This trial solution is suggested by the solution of the first order linear equation $y_1 + Py = 0$, which is of the same form.

The equation (3) is called the *Auxiliary equation of (2)*.

Let m_1, m_2 be the two roots of the equation (3).

Then, $y = e^{m_1 x}$, and $y = e^{m_2 x}$ are obviously solutions of (2). Also, it can be easily verified by direct substitution that $y = C_1 e^{m_1 x}$, $y = C_2 e^{m_2 x}$ and $y \equiv C_1 e^{m_1 x} + C_2 e^{m_2 x}$ satisfy the equation (2), and as such, are solutions of (2).

We shall now consider the nature of the general solution of the equation (2) according as the roots of the auxiliary equation (3) are (i) *real and distinct*, (ii) *real and equal* and (iii) *imaginary*.

(i) Auxiliary equation having real and distinct roots.

If m_1 and m_2 are real and distinct, then $y = C_1 e^{m_1 x} + C_2 e^{m_2 x}$ is the general solution, since it satisfies the equation, and contains two independent arbitrary constants equal in number to the order of the equation.

(ii) Auxiliary equation having two equal roots.

If the auxiliary equation has two equal roots, the method of the preceding paragraph does not lead to the general solution. For, if $m_1 = m_2 = a$ say, then the solution of the preceding paragraph assumes the form

$$y = (C_1 + C_2) e^{ax} = C e^{ax}, \text{ when } C_1 + C_2 = C$$

which is not the general solution, since it involves only one independent constant and the equation is of the second order.

A method will now be devised for finding the general solution in the case under discussion. Since the auxiliary equation (3) has two equal roots each being equal to a , it follows that the differential equation (2) assumes the form

$$\frac{d^2 y}{dx^2} - 2a \frac{dy}{dx} + a^2 y = 0.$$

Let $y = e^{\alpha x}v$, where v is a function of x , be a trial solution of this equation. Substituting this value of y in the left side of the above equation, we have

$$e^{\alpha x} \frac{d^2 v}{dx^2} = 0, \quad \text{i.e.,} \quad \frac{d^2 v}{dx^2} = 0, \quad \text{since } e^{\alpha x} \neq 0.$$

Now, integrating this twice, we get $v = C_1 + C_2x$.

Hence, the solution of (2) in this case is

$$y = (C_1 + C_2x) e^{\alpha x}.$$

This is the general solution of (2), since it satisfies (2), and contains two independent arbitrary constants.

(iii) Auxiliary equation having a pair of complex roots.

If $m_1 = \alpha + i\beta$ and $m_2 = \alpha - i\beta$, then the general solution of (2) is

$$y = C_1 e^{(\alpha + i\beta)x} + C_2 e^{(\alpha - i\beta)x}.$$

The above solution, by adjusting the arbitrary constants can be put in a more convenient form not involving imaginary expressions ; thus we have

$$\begin{aligned} y &= e^{\alpha x} [C_1 e^{i\beta x} + C_2 e^{-i\beta x}] \\ &= e^{\alpha x} [C_1 (\cos \beta x + i \sin \beta x) + C_2 (\cos \beta x - i \sin \beta x)] \\ &= e^{\alpha x} [(C_1 + C_2) \cos \beta x + i(C_1 - C_2) \sin \beta x] \\ &= e^{\alpha x} [A \cos \beta x + B \sin \beta x], \end{aligned}$$

where $A = C_1 + C_2$ and $B = i(C_1 - C_2)$ are the arbitrary constants which may be given any real values we like.

Again, by adjusting the arbitrary constants A and B suitably, *i.e.*, by putting $C \cos \varepsilon$ for A and $-C \sin \varepsilon$ for B , the general solution can also be written in the form

$$y = C e^{\alpha x} \cos (\beta x + \varepsilon),$$

where C and ε are the two arbitrary constants.

Ex. 1. Solve $\frac{d^2y}{dx^2} + 3\frac{dy}{dx} + 2y = 0$.

Let $y = e^{mx}$ be a solution of the above equation ;
 then $e^{mx} (m^2 + 3m + 2) = 0$, $\therefore m^2 + 3m + 2 = 0$, since $e^{mx} \neq 0$.
 $\therefore (m+1)(m+2) = 0$, $\therefore m = -1$, or, -2 .
 \therefore the general solution is $y = C_1 e^{-x} + C_2 e^{-2x}$

Ex. 2. Solve $\frac{d^2y}{dx^2} - 2a\frac{dy}{dx} + a^2y = 0$.

Let $y = e^{mx}$ be a solution of the above equation ;
 then $e^{mx} (m^2 - 2am + a^2) = 0$, or, $m^2 - 2am + a^2 = 0$, since $e^{mx} \neq 0$.
 $\therefore (m-a)^2 = 0$.

Since the auxiliary equation has repeated roots here,
 \therefore the general solution is $y = (C_1 + C_2 x) e^{ax}$.

Ex. 3. Solve $(D^2 + 2D + 5) y = 0$.

The equation is, $\frac{d^2y}{dx^2} + 2\frac{dy}{dx} + 5y = 0$.

Let $y = e^{mx}$ be a solution of the equation ;
 then $e^{mx} (m^2 + 2m + 5) = 0$. $\therefore m^2 + 2m + 5 = 0$ since $e^{mx} \neq 0$,
 $\therefore m = -1 \pm 2i$;

\therefore the general solution is $y = C_1 e^{(-1+2i)x} + C_2 e^{(-1-2i)x}$

which, as shown in Art. 17.2(iii) can be put in the form

$$y = e^{-x} (A \cos 2x + B \sin 2x).$$

EXAMPLES XVII(A)

Solve :—

1. $\frac{d^2y}{dx^2} + 5\frac{dy}{dx} + 4y = 0$.

2. $\frac{d^2y}{dx^2} - 7\frac{dy}{dx} + 12 = 0$.

$$3. \quad \frac{d^2y}{dx^2} - 3\frac{dy}{dx} + 2y = 0. \quad [C. P. 1930]$$

$$4. \quad \frac{d^2y}{dx^2} + (a+b)\frac{dy}{dx} + aby = 0. \quad [C. P. 1937]$$

$$5. \quad \text{(i) } 2\frac{d^2y}{dx^2} - 3\frac{dy}{dx} + y = 0. \quad \text{(ii) } \frac{d^2y}{dx^2} + 2\frac{dy}{dx} + y = 0. \\ [C. P. 1940]$$

$$6. \quad y_2 - 4y_1 + 4y = 0. \quad [C. P. 1939]$$

$$7. \quad \text{(i) } (D^2 + D)y = 0. \quad \text{(ii) } (D^2 + 6D + 25)y = 0.$$

$$8. \quad (D^2 - 2mD + m^2 + n^2)y = 0.$$

$$9. \quad \text{(i) } (D^2 - 4D + 13)y = 0. \quad \text{(ii) } (D^2 - n^2)y = 0.$$

$$10. \quad \text{(i) } \frac{d^2s}{dt^2} + 4\frac{ds}{dt} + 13s = 0. \quad \text{(ii) } (D + 3)^2y = 0.$$

11. Solve in the particular cases :—

$$\text{(i) } \frac{d^2y}{dx^2} + \frac{dy}{dx} - 2y = 0 ; \text{ when } x = 0, y = 3 \text{ and } \frac{dy}{dx} = 0.$$

$$\text{(ii) } \frac{d^2y}{dx^2} + y = 0 ; \text{ when } x = 0, y = 4 ; \text{ when } x = \frac{1}{2}\pi, y = 0.$$

$$\text{(iii) } \frac{d^2x}{dt^2} - 3\frac{dx}{dt} + 2x = 0 ; \text{ when } t = 0, x = 2 \text{ and } \frac{dx}{dt} = 0.$$

$$\text{(iv) } \frac{d^2x}{dt^2} + n^2x = 0 ; \text{ when } t = 0, \frac{dx}{dt} = 0 \text{ and } x = a.$$

12. Find the curve for which the curvature is zero at every point.

13. Show that if $l\frac{d^2\theta}{dt^2} + g\theta = 0$, and if $\theta = a$ and $\frac{d\theta}{dt} = 0$, when $t = 0$, then $\theta = a \cos \{t \sqrt{(g/l)}\}$.

14. Show that the solution of

$$\frac{d^2x}{dt^2} + k \frac{dx}{dt} + \mu x = 0$$

is $x = e^{-\frac{1}{2}kt} (A \cos nt + B \sin nt)$ if $k^2 < 4\mu$,

and $n^2 = \mu - \frac{1}{4}k^2$.

ANSWERS

1. $y = c_1 e^{-x} + c_2 e^{-4x}$. 2. $y = c_1 e^{3x} + c_2 e^{11x}$. 3. $y = c_1 e^x + c_2 e^{2x}$.
 4. $y = c_1 e^{-ax} + c_2 e^{-bx}$. 5. (i) $y = c_1 e^x + c_2 e^{t/2}$. (ii) $y = (A + Bx)e^{-x}$.
 6. $y = e^{2x} (A + Bx)$. 7. (i) $y = A + Be^{-x}$.
 (ii) $y = e^{-2x} (A \cos 4x + B \sin 4x)$.
 8. $y = e^{mx} (A \cos nx + B \sin nx)$.
 9. (i) $y = e^{2x} (A \cos 3x + B \sin 3x)$. (ii) $y = Ae^{nx} + Be^{-nx}$.
 10. (i) $s = e^{-2t} (A \cot 3t + B \sin 3t)$. (ii) $y = e^{-3x} (A + Bx)$.
 11. (i) $y = 2e^x + e^{-2x}$. (ii) $y = 4 \cos x$. (iii) $x = 4e^t - 2e^{2t}$.
 (iv) $x = a \cos nt$. 12. A straight line.

17.3. Right-hand member a function of x.

We shall now consider the solution of the general form

$$\frac{d^2y}{dx^2} + P_1 \frac{dy}{dx} + P_2 y = X. \quad \dots (1)$$

If $y = \phi(x)$ be the general solution of

$$\frac{d^2y}{dx^2} + P_1 \frac{dy}{dx} + P_2 y = 0 \quad \dots (2)$$

and $y = \psi(x)$ be any particular solution of (1), then

$y = \phi(x) + \psi(x)$ is the general solution of (1).

This result can be established by direct substitution.

Thus, substituting $y = \phi(x) + \psi(x)$ in the left side of (1), we have

$$\left\{ \frac{d^2\phi}{dx^2} + P_1 \frac{d\phi}{dx} + P_2\phi \right\} + \left\{ \frac{d^2\psi}{dx^2} + P_1 \frac{d\psi}{dx} + P_2\psi \right\}.$$

The first group of terms is zero, since $y = \phi(x)$ is a solution of (2), and the second group of terms is equal to X , since $y = \psi(x)$ is a solution of (1).

Hence, $y = \phi(x) + \psi(x)$ is a solution of (1), and it is the general solution, since the number of independent arbitrary constants in it is two, $\phi(x)$ being the general solution of (2).

Thus, we see that the process of solving equation (1) is naturally divided into two parts; the first is to find the general solution of (2), say $\phi(C_1, C_2, x)$, and the next is to find any particular solution of (1), say $\psi(x)$ not containing any arbitrary constant. Then

$$y = \phi(C_1, C_2, x) + \psi(x)$$

will be the general solution of (1).

The expression $\phi(C_1, C_2, x)$ is called the *Complementary function* and $\psi(x)$, *i.e.*, any particular solution of (1) is called the *Particular Integral* of the equation (1).

17.4. Symbolical Operators.

We have already shown in art. 17.2 how to obtain the Complementary function; now we shall consider how to obtain the Particular integral. In order to discuss methods of finding a particular integral, it would be convenient to introduce certain symbolical operators and their properties.

With the usual notation of Differential Calculus $\frac{d}{dx}$, $\frac{d^2}{dx^2}$, etc. will be denoted by the symbols D , D^2 , etc. Also $\frac{1}{D}$ (or, D^{-1}), $\frac{1}{D^2}$ (or, D^{-2}), etc. will be used to denote the inverse operators, *i.e.*, the operators which integrate a function with respect to x , once, twice, etc. Let us write the equation

$$\frac{d^2 y}{dx^2} + P_1 \frac{dy}{dx} + P_2 y = X, \quad \dots \quad (1)$$

in its symbolic form

$$(D^2 + P_1 D + P_2)y = X, \quad \dots \quad (2)$$

or, more briefly as $f(D)y = X$ (3)

The expression $\frac{1}{f(D)} X$ will be used to denote a function of x not involving arbitrary constants, such that the result of operating upon it with $f(D)$ is X , and as such $\frac{1}{f(D)}$ and $f(D)$ denote two inverse operators.

Thus, the function $\frac{1}{f(D)} X$ is clearly a Particular Integral of the equation $f(D)y = X$.

As a particular case when $f(D) = D$, $\frac{1}{D} X$ will denote a function of x , obtained by integrating X once with respect to x , which does not contain any arbitrary constant of integration; similarly $\frac{1}{D^2} X$ will denote a function of x , obtained by integrating X twice with respect to x , and not

containing any arbitrary constant of integration. For example,

$$\frac{1}{D} x^4 = \frac{1}{5} x^5; \quad \frac{1}{D^2} x^3 = \frac{1}{20} x^5; \quad \frac{1}{D} 1 = x; \quad \frac{1}{D^2} 1 = \frac{1}{2} x^2.$$

Important Results on Symbolical Operation.

If $F(D)$ be any rational integral function of D ,

i.e., if $F(D) = D^n + a_1 D^{n-1} + \dots + a_{n-1} D + a_n$, then

$$(i) \quad F(D) e^{ax} = F(a) e^{ax}.$$

$$(ii) \quad F(D) e^{ax} V = e^{ax} F(D+a) V, \quad V \text{ being a function of } x.$$

$$(iii) \quad F(D^2) \begin{cases} \sin(ax+b) \\ \cos(ax+b) \end{cases} = F(-a^2) \begin{cases} \sin(ax+b) \\ \cos(ax+b) \end{cases}.$$

By actual differentiation, we can easily verify the above results.

17.5. Methods of finding Particular Integrals.

We shall discuss here the methods of obtaining particular integrals, *i.e.*, the methods of evaluating $\frac{1}{f(D)} X$, when X has special forms.*

(a) $X = x^m$, m being a positive integer.

Expand $\frac{1}{f(D)}$, *i.e.*, $\{f(D)\}^{-1}$ in ascending powers of D and operate on x^m with the result. It is clear that in the expansion, no terms beyond the one containing D^m need be retained, since $D^{m+1} x^m = 0$.

Note. The justification of the above method lies in the fact that the function of x which we shall get by operating on x^m by the series

* For proof see Authors' Differential Calculus.

of powers of D obtained by expanding $\{f(D)^{-1}\}$, when operated upon by $f(D)$, will give x^m . For example,

$$\frac{1}{D^2+1} x^4 = (1+D^2)^{-1} x^4 = (1-D^2+D^4-\dots)x^4 = x^4 - 12x^2 + 24.$$

Now, $(D^2+1)(x^4 - 12x^2 + 24) = 12x^2 - 24 + x^4 - 12x^2 + 24 = x^4$.

(b) $X = e^ax V$, where V is a function of x , or a constant.

If V_1 is a function of x , we have from Art. 17'4(ii),

$$f(D)e^{ax}V_1 = e^{ax}f(D+a)V_1 = e^{ax}V, \text{ say,}$$

so that, $f(D+a)V_1 = V$, i.e., $V_1 = \frac{1}{f(D+a)}V$.

Thus, $\frac{1}{f(D)}e^{ax}V = e^{ax}V_1 = e^{ax}\frac{1}{f(D+a)}V$.

Again, noticing that $f(D+a)k'$ where k' is a constant is evidently a constant $= k$ say, and proceeding exactly as above we can show that

$$\frac{1}{f(D)}e^{ax}k = e^{ax} \frac{1}{f(D+a)}k = ke^{ax} \frac{1}{f(D+a)} 1.$$

(c) $X = e^{ax}$. where a is any constant.

If $f(a) \neq 0$, $f(D)\left\{\frac{e^{ax}}{f(a)}\right\} = \frac{1}{f(a)} \cdot f(a) e^{ax} = e^{ax}$.

[From Art. 17'4(i)]

$\therefore \frac{1}{f(D)}e^{ax} = \frac{1}{f(a)}e^{ax}$, provided $f(a) \neq 0$.

If $f(a) = 0$, then $(D-a)$ is a factor of $f(D)$.

\therefore either, $f(D) = (D-a)\phi(D)$, where $\phi(a) \neq 0 \dots$ (i)

or else, $= (D-a)^2 \dots \dots$ (ii)

$$(i) \frac{1}{f(D)} e^{ax} = \frac{1}{D-a} \cdot \frac{1}{\phi(D)} e^{ax} = \frac{1}{D-a} \cdot \frac{e^{ax}}{\phi(a)} = \frac{1}{\phi(a)} \cdot \frac{e^{ax}}{D-a}$$

$$= \frac{e^{ax}}{\phi(a)} \cdot \frac{1}{D} \cdot 1 \text{ [by (b)]} = \frac{x e^{ax}}{\phi(a)}.$$

$$(ii) \frac{1}{f(D)} e^{ax} = \frac{1}{(D-a)^2} e^{ax} = e^{ax} \frac{1}{D^2} \cdot 1 \text{ [by (b)]} = e^{ax} \cdot \frac{x^2}{2}.$$

(d) $X = \sin(ax+b)$ or $\cos(ax+b)$.

If $f(D)$ contains only even powers of D , let us denote it by $\phi(D^2)$. Then if $\phi(-a^2) \neq 0$, we get by Art. 17'4(iii),

$$\phi(D^2) \frac{\sin(ax+b)}{\phi(-a^2)} = \phi(-a^2) \frac{\sin(ax+b)}{\phi(-a^2)} = \sin(ax+b).$$

$$\therefore \frac{1}{\phi(D^2)} \sin(ax+b) = \frac{1}{\phi(-a^2)} \sin(ax+b), \text{ if } \phi(-a^2) \neq 0.$$

$$\text{Similarly, } \frac{1}{\phi(D^2)} \cos(ax+b) = \frac{1}{\phi(-a^2)} \cos(ax+b), \text{ if } \phi(-a^2) \neq 0.$$

If $\phi(-a^2) = 0$, or if $f(D)$ contains both the first and the second powers of D , the method of procedure that is to be adopted in such cases is illustrated in Ex. 5 and Ex. 6 of § 17'6 below.

(e) $X = x^m \sin(ax+b)$ or $x^m \cos(ax+b)$.

(f) $X = xV$, where V is any function of x

$$\frac{1}{f(D)} xV = \left\{ x - \frac{1}{f(D)} \cdot f'(D) \right\} \frac{1}{f(D)} V.*$$

In evaluating particular integrals of this type it is convenient to replace $\sin(ax+b)$ and $\cos(ax+b)$ by their exponential values and then proceed as in case (b).

Note. It should be noted that when X is the sum or difference of two or more functions of x , say $X = X_1 \pm X_2 \pm X_3$, then the particular integral = $\frac{1}{f(D)} \{X_1 \pm X_2 \pm X_3\} = \frac{1}{f(D)} X_1 \pm \frac{1}{f(D)} X_2 \pm \frac{1}{f(D)} X_3$.

* For proof, see the Appendix.

17'5 (1). Alternative method of finding $\frac{1}{f(D)} X$.

When the auxiliary equation has real and distinct roots, corresponding to each such root m , there will be a partial fraction of the form $\frac{A}{D - m}$, where A is a known constant and hence

$\frac{1}{f(D)} X$ can be written in the form

$$\frac{A_1}{D - m_1} X + \frac{A_2}{D - m_2} X + \dots\dots$$

each term of which can be evaluated by the method shown below.

Now, $\frac{1}{D - m} X = \frac{1}{D - m} e^{mx} e^{-mx} X = e^{mx} \frac{1}{D} e^{-mx} X.$

$$\therefore \frac{1}{D - m} X = e^{mx} \int e^{-mx} X dx. \quad \dots \quad \dots \quad (1)$$

This method is illustrated in *Ex. 8 of Art. 17'6*.

17'6. Illustrative Examples.

Ex. 1. Solve $(D^2 + 4) y = x^2$. [C. P. 1935]

Here, the auxiliary equation $m^2 + 4 = 0$ has roots $m = \pm 2i$

\therefore the complementary function = $A \cos 2x + B \sin 2x$.

$$\begin{aligned} \text{Particular Integral} &= \frac{1}{D^2 + 4} x^2 = \frac{1}{4(1 + \frac{1}{4}D^2)} x^2 \\ &= \frac{1}{4}(1 + \frac{1}{4}D^2)^{-1} x^2 \\ &= \frac{1}{4}(1 - \frac{1}{4}D^2 + \frac{1}{16}D^4 - \dots) x^2 = \frac{1}{4}(x^2 - \frac{1}{2}). \end{aligned}$$

\therefore the required general solution is

$$y = A \cos 2x + B \sin 2x + \frac{1}{4}(x^2 - \frac{1}{2}).$$

Ex. 2. Solve $(D-3)^2 y = 2e^{4x}$.

Here, the auxiliary equation $(m-3)^2 = 0$ has roots 3, 3.

\therefore C. F. = $(A+Bx)e^{3x}$.

$$\text{P. I.} = \frac{1}{(D-3)^2} 2e^{4x} = \frac{2e^{4x}}{(4-3)^2} = 2e^{4x}.$$

\therefore the general solution is $y = (A+Bx)e^{3x} + 2e^{4x}$.

Ex. 3. Solve $(D-2)^2 y = 6e^{2x}$.

Here, the auxiliary equation $(m-2)^2 = 0$ has roots 2, 2.

\therefore C. F. = $(A+Bx)e^{2x}$.

$$\text{P. I.} = \frac{1}{(D-2)^2} 6e^{2x} = 6e^{2x} \cdot \frac{1}{D^2} 1 = 6e^{2x} \cdot \frac{1}{2} x^2 = 3x^2 e^{2x}.$$

\therefore the general solution is $y = (A+Bx)e^{2x} + 3x^2 e^{2x}$.

Ex. 4. Solve $\frac{d^2 y}{dx^2} + y = \cos 2x$. [C. P. 1937]

The equation can be written as $(D^2+1)y = \cos 2x$.

The auxiliary equation $m^2+1=0$ has roots $\pm i$.

\therefore C. F. = $A \cos x + B \sin x$.

$$\text{P. I.} = \frac{1}{D^2+1} \cos 2x = \frac{\cos 2x}{-2^2+1} = -\frac{1}{3} \cos 2x.$$

\therefore the general solution is $y = A \cos x + B \sin x - \frac{1}{3} \cos 2x$.

Ex. 5. Solve $(D^2+1)y = \cos x$.

As in Ex. 4, C. F. = $A \cos x + B \sin x$.

But the method of obtaining particular integral employed in Ex. 4 fails here. We may however substitute the exponential value of $\cos x$ and proceed. Alternatively we may proceed as follows :

$$\text{Let } Y = \frac{1}{D^2+1} \cos x \text{ and } Z = \frac{1}{D^2+1} \sin x,$$

$$\begin{aligned} \therefore Y+iZ &= \frac{1}{D^2+1} (\cos x + i \sin x) = \frac{1}{D^2+1} e^{ix} \\ &= e^{ix} \frac{1}{(D+i)^2+1} \cdot 1 = e^{ix} \frac{1}{2iD+D^2} \cdot 1 \end{aligned}$$

$$\begin{aligned} &= e^{ix} \frac{1}{2iD} \left(1 + \frac{D}{2i}\right)^{-1} \cdot 1 = e^{ix} \frac{1}{2i} \frac{1}{D} \cdot 1 \\ &= e^{ix} \frac{x}{2i} = \frac{x}{2i} (\cos x + i \sin x). \end{aligned}$$

∴ equating the real part, $Y = \frac{1}{2}x \sin x$.

∴ the general solution is $y = A \cos x + B \sin x + \frac{1}{2}x \sin x$.

Ex. 6. Solve $\frac{d^2 y}{dx^2} - 2 \frac{dy}{dx} + 5y = 10 \sin x$.

The equation can be written as $(D^2 - 2D + 5)y = 10 \sin x$.

The auxiliary equation $m^2 - 2m + 5 = 0$ has roots $1 \pm 2i$.

∴ C. F. = $e^x (A \cos 2x + B \sin 2x)$.

$$\begin{aligned} \text{P. I.} &= \frac{1}{D^2 - 2D + 5} 10 \sin x = \frac{(D^2 + 5) + 2D}{(D^2 + 5)^2 - 4D^2} 10 \sin x \\ &= \frac{D^2 + 2D + 5}{(-1^2 + 5)^2 + 4} 10 \sin x = \frac{1}{2} (D^2 + 2D + 5) \sin x \\ &= \frac{1}{2} (-\sin x + 2 \cos x + 5 \sin x) = 2 \sin x + \cos x. \end{aligned}$$

∴ the general solution is $y = e^x (A \cos 2x + B \sin 2x) + 2 \sin x + \cos x$.

Ex. 7. Solve $(D^2 - 4D + 4)y = x^3 e^{2x}$.

The auxiliary equation $m^2 - 4m + 4 = 0$ has roots 2, 2.

∴ C. F. = $(Ax + B) e^{2x}$.

$$\begin{aligned} \text{P. I.} &= \frac{1}{D^2 - 4D + 4} x^3 e^{2x} = \frac{1}{(D - 2)^2} x^3 e^{2x} \\ &= e^{2x} \frac{1}{D^2} x^3 = e^{2x} \cdot \frac{x^3}{20}. \end{aligned}$$

∴ the general solution is $y = (Ax + B) e^{2x} + \frac{1}{20} e^{2x} x^3$.

Ex. 8. Evaluate $\frac{1}{D^2 + 3D + 2} e^{e^x}$.

Given expression = $\frac{1}{(D+1)(D+2)} e^{e^x}$ (1)

$$= \left[\frac{1}{D+1} - \frac{1}{D+2} \right] e^{e^x}$$

$$\begin{aligned}
&= \frac{1}{D+1} e^{e^x} - \frac{1}{D+2} e^{e^x} \\
&= e^{-x} \int e^x e^{e^x} dx - e^{-2x} \int e^{2x} e^{e^x} dx \quad \dots (2)
\end{aligned}$$

Let $I_1 = \int e^x e^{e^x} dx$ and $I_2 = \int e^{2x} e^{e^x} dx$.

Put $e^x = z$. $\therefore e^x dx = dz$.

$$\therefore I_1 = \int e^z dz = e^z = e^{e^x}$$

$$I_2 = \int ze^z dz = ze^z - \int e^z dz = ze^z - e^z = e^z(z-1) = e^{e^x}(e^x - 1).$$

\therefore from (2), the given expression

$$\begin{aligned}
&= e^{-x} e^{e^x} - e^{-2x} \cdot e^{e^x} (e^x - 1) \\
&= e^{-2x} e^{e^x}.
\end{aligned}$$

17.7. Two special types of Second order equations.

(A) $\frac{d^2y}{dx^2} = f(x)$.

Integrating both sides with respect to x , we have

$$\frac{dy}{dx} = \int f(x) dx + A = \phi(x) + A \text{ say.}$$

Integrating again,

$$y = \int \phi(x) dx + Ax + B = \psi(x) + Ax + B \text{ say.}$$

Note. As a generalisation of the above method, we can solve the equation $\frac{d^n y}{dx^n} = f(x)$ and in particular $\frac{d^n y}{dx^n} = 0$, by successive integration.

(B) $\frac{d^2y}{dx^2} = f(y)$.

Multiplying both sides by $2dy/dx$, we get

$$2 \frac{dy}{dx} \cdot \frac{d^2y}{dx^2} = 2f(y) \frac{dy}{dx},$$

or,
$$\frac{d}{dx} \left\{ \frac{dy}{dx} \right\}^2 = 2f(y) \frac{dy}{dx}.$$

Now, integrating both sides with respect to x , we have

$$\left(\frac{dy}{dx} \right)^2 = 2 \int f(y) \frac{dy}{dx} dx + C_1 = 2 \int f(y) dy + C_1.$$

Let $2 \int f(y) dy = \phi(y).$

$$\therefore \frac{dy}{dx} = \pm \sqrt{\phi(y) + C_1}.$$

$$\therefore dx = \pm \frac{dy}{\sqrt{\phi(y) + C_1}}, \text{ whence integrating}$$

$$x = \pm \psi(y, C_1) + C_2 \text{ (say).}$$

17.7 (1). Illustrative Examples.

Ex. 1. Solve $\frac{d^2y}{dx^2} = \cos nx.$

Integrating both sides with respect to x , we have

$$\frac{dy}{dx} = \frac{1}{n} \sin nx + A.$$

Integrating again, $y = -\frac{1}{n^2} \cos nx + Ax + B,$

which is the general solution.

Ex. 2. Solve $\frac{d^2y}{dx^2} = \frac{a}{y^3}.$

Multiplying both sides by $2 \frac{dy}{dx}$, we get

$$2 \frac{dy}{dx} \cdot \frac{d^2y}{dx^2} = 2 \cdot \frac{a}{y^3} \frac{dy}{dx}, \text{ or, } \frac{d}{dx} \left(\frac{dy}{dx} \right)^2 = 2a \frac{1}{y^3} \frac{dy}{dx}.$$

Now integrating both sides with respect to x , we have

$$\begin{aligned} \left(\frac{dy}{dx}\right)^2 &= 2a \int \frac{1}{y^3} dy + C_1 \\ &= -\frac{2a}{y^2} \cdot \frac{1}{2} + C_1 = C_1 - \frac{a}{y^2} = \frac{C_1 y^2 - a}{y^2}. \end{aligned}$$

$$\frac{dy}{dx} = \pm \frac{\sqrt{C_1 y^2 - a}}{y} \quad \text{or,} \quad \int dx = \pm \int \frac{y dy}{\sqrt{C_1 y^2 - a}}.$$

$$\therefore x = \pm \frac{1}{C_1} \sqrt{C_1 y^2 - a} + C_2,$$

$$\therefore x - C_2 = \pm \frac{1}{C_1} \sqrt{C_1 y^2 - a}.$$

$$\therefore C_1^2 (x - C_2)^2 = C_1 y^2 - a.$$

This is the general solution.

Note. An alternative method of procedure for solution of the equations of the above type, *i.e.*, of the type $\frac{d^2 y}{dx^2} = f(y)$ is indicated below.

$$\text{Put } \frac{dy}{dx} = p. \quad \therefore \frac{d^2 y}{dx^2} = \frac{dp}{dx} = \frac{dp}{dy} \frac{dy}{dx} = p \frac{dp}{dy}.$$

$$\therefore p \frac{dp}{dy} = \frac{a}{y^3}, \quad \text{or, } p dp = ay^{-3} dy,$$

$$\therefore \text{integrating, } \frac{1}{2} p^2 = -\frac{1}{2} ay^{-2} + \frac{C_1}{2}.$$

$$\therefore p^2, \text{ i.e., } \left(\frac{dy}{dx}\right)^2 = C_1 - \frac{a}{y^2}.$$

Now, the rest is the same as before.

$$\text{Ex. 3. Solve } x^2 \frac{d^2 y}{dx^2} + x \frac{dy}{dx} + n^2 y = 0.$$

Put $x = e^z$, so that $z = \log x$;

$$\text{then } \frac{dx}{dz} = e^z = x.$$

$$\therefore \frac{dy}{dz} = \frac{dy}{dx} \frac{dx}{dz} = x \frac{dy}{dx} \quad \text{and} \quad \frac{d^2 y}{dz^2} = \frac{d}{dx} \left(x \frac{dy}{dx} \right) \frac{dx}{dz} = \left(x \frac{d^2 y}{dx^2} + \frac{dy}{dx} \right) x,$$

$$\text{i.e., } x^2 \frac{d^2 y}{dx^2} + x \frac{dy}{dx} = \frac{d^2 y}{dz^2}.$$

∴ the given equation reduces to

$$\frac{d^2y}{dz^2} + n^2y = 0.$$

Multiplying by $2\frac{dy}{dz}$ and integrating with respect to z ,

$$\left(\frac{dy}{dz}\right)^2 + n^2y^2 = \text{constant} = n^2a^2 \text{ (say).}$$

$$\therefore \frac{dy}{dz} = \pm n\sqrt{a^2 - y^2},$$

$$\text{or, } \pm \int \frac{dy}{\sqrt{a^2 - y^2}} = n \int dz.$$

$$\therefore \text{integrating, } \mp \cos^{-1} \frac{y}{a} = nz + e$$

whence, $y = a \cos (nz + e)$, or, $y = a \cos (n \log x + e)$ is the required solution, a and e being arbitrary constants of integration.

17.7 (2). Equations of the types

$$(A) \quad F\left(\frac{d^ny}{dx^n}, \dots, \frac{dy}{dx}, x\right) = 0.$$

$$(B) \quad F\left(\frac{d^ny}{dx^n}, \dots, \frac{dy}{dx}, y\right) = 0.$$

(A) These equations do not contain y directly. The substitution is $\frac{d^ry}{dx^r}$ (derivative of the lowest order) = q .

(B) These equations do not contain x directly. The substitution is $\frac{dy}{dx} = p$.

$$\text{Then } \frac{d^2y}{dx^2} = p \frac{dp}{dy}; \quad \frac{d^3y}{dx^3} = p^2 \frac{d^2p}{dy^2} + p \left(\frac{dp}{dy}\right)^2 \text{ etc.}$$

17.7 (3). Illustrative Examples.

Ex. 1. Solve $2x \frac{d^3y}{dx^3} \cdot \frac{d^2y}{dx^2} - \left(\frac{d^2y}{dx^2}\right)^2 + 1 = 0.$

Put $\frac{d^2y}{dx^2} = q$; $\therefore \frac{d^3y}{dx^3} = \frac{dq}{dx}$,

\therefore the given equation becomes

$$2x \frac{dq}{dx} q - q^2 + 1 = 0,$$

$\therefore \frac{2q}{q^2 - 1} dq = \frac{dx}{x}$ or, $\log(q^2 - 1) = \log c_1 x$.

$\therefore q^2 - 1 = c_1 x$.

$\therefore q$ i.e., $\frac{d^2y}{dx^2} = \sqrt{1 + c_1 x}$,

$\therefore \frac{dy}{dx} = \frac{2}{3c_1} (1 + c_1 x)^{\frac{3}{2}} + c_2$,

$\therefore y = \frac{2}{3c_1} \cdot \frac{2}{5c_1} (1 + c_1 x)^{\frac{5}{2}} + c_2 x + c_3$
 $= \frac{4}{15c_1^2} (1 + c_1 x)^{\frac{5}{2}} + c_2 x + c_3$,

$\therefore 15c_1^2 y = 4(1 + c_1 x)^{\frac{5}{2}} + c_2 x + c_3$.

Ex. 2. Solve $y \frac{d^2y}{dx^2} - \left(\frac{dy}{dx}\right)^2 + \left\{ \left(\frac{dy}{dx}\right)^2 - \left(\frac{d^2y}{dx^2}\right)^2 \right\}^{\frac{1}{2}} = 0$.

Put $\frac{dy}{dx} = p$. $\therefore \frac{d^2y}{dx^2} = p \frac{dp}{dy}$,

\therefore the equation transforms into

$$yp \frac{dp}{dy} - p^2 + \left\{ p^2 - p^2 \left(\frac{dp}{dy}\right)^2 \right\}^{\frac{1}{2}} = 0.$$

$\therefore p = qy + (1 - q^2)^{\frac{1}{2}}$, where $q = \frac{dp}{dy}$.

This is *Clairauts' form*.

$\therefore p = Ay + (1 - A^2)^{\frac{1}{2}} = Ay + k$ say where $k = (1 - A^2)^{\frac{1}{2}}$.

$\therefore dx = \frac{dy}{Ay + k}$

$\therefore x + B = \frac{1}{A} \log(Ay + k) = \frac{1}{A} \log \{Ay + (1 - A^2)^{\frac{1}{2}}\}$.

EXAMPLES XVII(B)

Solve the following equations :—

- | | |
|--|---|
| 1. (i) $\frac{d^2 y}{dx^2} + 4y = 2x + 3.$ | (ii) $\frac{d^2 y}{dx^2} + y = x^3.$ |
| 2. (i) $\frac{d^2 y}{dx^2} + 2\frac{dy}{dx} = x^2.$ | (ii) $\frac{d^2 y}{dx^2} + \frac{dy}{dx} - 6y = x.$ |
| 3. (i) $(D + 3)^2 y = 25e^{2x}.$ | (ii) $(D^2 + 9)y = 9e^{3x}.$ |
| 4. (i) $\frac{d^2 y}{dx^2} - a^2 y = e^{ax}.$ | (ii) $\frac{d^2 y}{dx^2} - y = e^{2x}.$ |
| (iii) $\frac{d^2 y}{dx^2} - 4\frac{dy}{dx} + 3y = 2e^{3x}.$ | [C. P. 1939] |
| 5. (i) $(D^2 - 4)y = \sin 2x.$ | (ii) $(D^2 + 4)y = \sin 2x.$ |
| 6. (i) $\frac{d^2 y}{dx^2} + y = \sin x.$ | (ii) $\frac{d^2 y}{dx^2} + 4y = x \cos x.$ |
| (iii) $\frac{d^2 y}{dx^2} + y = \cos^2 x.$ | (iv) $\frac{d^2 y}{dx^2} + 4y = x \sin^2 x.$ |
| 7. (i) $(D^2 - 1)y = xe^{2x}.$ | (ii) $(D^2 - 9)y = e^{3x} \cos x.$ |
| 8. (i) $(D^2 + 2D + 2)y = xe^{-x}.$ | (ii) $(D^2 - 1)y = e^x \sin \frac{1}{2}x.$ |
| (iii) $(D^2 + 1)y = \sin x \sin 2x.$ | |
| (iv) $(D^2 - D - 2)y = \sin 2x.$ | (v) $(D - 2)^2 y = x^2 e^{2x}.$ |
| 9. (i) $\frac{d^2 y}{dx^2} + 2\frac{dy}{dx} + y = e^x + e^{-x}.$ | |
| (ii) $\frac{d^2 y}{dx^2} - 2k\frac{dy}{dx} + k^2 y = e^x.$ | |
| (iii) $\frac{d^2 y}{dx^2} - 2\frac{dy}{dx} + y = e^x.$ | |
| (iv) $\frac{d^2 y}{dx^2} - y = \cosh x.$ | (v) $\frac{d^2 y}{dx^2} - y = xe^x \sin x.$ |

$$10. \quad x^2 \frac{d^2 y}{dx^2} - x \frac{dy}{dx} + y = \log x. \quad [\text{Put } x = e^x]$$

$$11. \quad (x^2 D^2 + xD + 1)y = \sin \log x^2. \quad [\text{Put } x = e^x]$$

12. (i) Show that the general solution of the equation for S. H. M. viz.,

$$\frac{d^2 x}{dt^2} = -n^2 x, \text{ is } x = A \cos (nt + \epsilon).$$

$$(ii) \text{ Evaluate } \frac{1}{D} e^{ax} \cos bx$$

and hence show that

$$\int e^{ax} \cos bx \, dx = \frac{e^{ax}}{a^2 + b^2} (a \cos bx + b \sin bx).$$

13. Solve in the particular cases :—

$$(i) \quad \frac{d^2 y}{dx^2} + y = \sin 2x; \text{ when } x = 0, y = 0 \text{ and } \frac{dy}{dx} = 0.$$

$$(ii) \quad y_2 - 5y_1 + 6y = 2e^x; \text{ when } x = 0, y = 1 \text{ and } y_1 = 1.$$

$$(iii) \quad (D^2 - 4D + 4)y = x^2; \text{ when } x = 0, y = \frac{3}{8} \text{ and } Dy = 1.$$

$$(iv) \quad (D^2 - 1)y = 2; \text{ given } Dy = 3, \text{ when } y = 1; \text{ and } x = 2,$$

when $y = -1$.

Solve :—

$$14. (i) \quad x \frac{d^2 y}{dx^2} = 1.$$

$$(ii) \quad \frac{d^2 y}{dx^2} = xe^x.$$

$$15. (i) \quad y_2 \cos^2 x = 1.$$

$$(ii) \quad y^3 y_2 = a.$$

$$16. \quad y'' = \tan y \sec^2 y, \text{ given } y' = 0, \text{ when } y = 0.$$

$$17. (i) \quad \frac{d^2 y}{dx^2} = \frac{1}{\sqrt{y}}.$$

$$(ii) \quad \frac{d^2 y}{dx^2} + y^2 = 0.$$

$$18. (i) \quad \frac{d^2 y}{dx^2} = x^2 \sin x.$$

$$(ii) \quad \frac{d^2 x}{dt^2} = x^2 t$$

19. (i) $x \frac{d^2 y}{dx^2} = 2 \frac{dy}{dx}$. (ii) $a \frac{d^2 y}{dx^2} = \frac{dy}{dx}$

20. $\frac{d^2 y}{dx^2} + \frac{dy}{dx} = e^x$.

21. $(1 + x^2)y_2 + 2xy_1 = 2$.

22. $y \frac{d^2 y}{dx^2} - \left(\frac{dy}{dx}\right)^2 + y^2 \log y = 0$.

23. $\frac{d^2 y}{dx^2} + \left(\frac{dy}{dx}\right)^2 + \frac{dy}{dx} = 0$.

24. $y_2 - (y_1)^2 = 0$.

25. $yy_2 + (y_1)^2 = 2$.

26. $\frac{d^4 y}{dx^4} - \frac{d^2 y}{dx^2} = 0$.

ANSWERS

1. (i) $y = A \cos 2x + B \sin 2x + \frac{1}{4}(2x + 3)$.

(ii) $y = A \cos x + B \sin x + (x^3 - 6x)$.

2. (i) $y = Ae^{-2x} + B + \frac{1}{8}x^3 - \frac{1}{4}x^2 + \frac{1}{4}x$. (ii) $y = Ae^{2x} + Be^{-3x} - \frac{1}{6}(x + \frac{1}{6})$.

3. (i) $y = (C_1 + C_2 x)e^{-3x} + e^{2x}$. (ii) $y = A \cos 3x + B \sin 3x + \frac{1}{2}e^{3x}$.

4. (i) $y = C_1 e^{ax} + C_2 e^{-ax} + \frac{x}{2a} e^{ax}$. (ii) $y = Ae^x + Be^{-x} + \frac{1}{3}e^{3x}$.

(iii) $y = C_1 e^x + C_2 e^{3x} + xe^{3x}$.

5. (i) $y = Ae^{2x} + Be^{-2x} - \frac{1}{8} \sin 2x$.

(ii) $y = A \cos 2x + B \sin 2x - \frac{1}{4}x \cos 2x$.

6. (i) $y = A \cos x + B \sin x - \frac{1}{2}x \cos x$.

(ii) $y = C_1 \cos 2x + C_2 \sin 2x + \frac{1}{8}x \cos x + \frac{3}{8} \sin x$.

(iii) $y = A \cos x + B \sin x + \frac{1}{2} - \frac{1}{8} \cos 2x$.

(iv) $y = A \cos 2x + B \sin 2x + \frac{1}{8}x - \frac{1}{4}x \cos 2x - \frac{1}{16}x^2 \sin 2x$.

7. (i) $y = C_1 e^x + C_2 e^{-x} + \frac{1}{8} e^{2x} (3x - 4)$.
 (ii) $y = C_1 e^{3x} + C_2 e^{-3x} + \frac{1}{37} e^{3x} (6 \sin x - \cos x)$.
8. (i) $y = e^{-x} (A \cos x + B \sin x + x)$.
 (ii) $y = A e^x + B e^{-x} - \frac{1}{17} e^x (\sin \frac{1}{2}x + 4 \cos \frac{1}{2}x)$.
 (iii) $y = A \cos x + B \sin x + \frac{1}{4}x \sin x + \frac{1}{8} \cos 3x$.
 (iv) $y = A e^{-x} + B e^{2x} + \frac{1}{25} (\cos 2x - 3 \sin 2x)$.
 (v) $y = e^{2x} (A + Bx + \frac{1}{12}x^4)$.
9. (i) $y = e^{-x} (C_1 + C_2 x + \frac{1}{2}x^2) + \frac{1}{4}e^x$. (ii) $y = (A + Bx)e^{kx} + e^x (1 - k)^{-2}$.
 (iii) $y = (A + Bx + \frac{1}{2}x^2) e^x$. (iv) $y = A e^x + B e^{-x} + \frac{1}{2}x \sinh x$.
 (v) $y = A e^x + B e^{-x} - \frac{e^x}{25} \{(10x + 2) \cos x + (5x - 14) \sin x\}$.
10. $y = (A + B \log x) x + \log x + 2$.
11. $y = A \cos \log x + B \sin \log x - \frac{1}{3} \sin \log x^2$.
13. (i) $y = \frac{2}{3} \sin x - \frac{1}{3} \sin 2x$. (ii) $y = e^x$.
 (iii) $y = \frac{1}{2}x e^{2x} + \frac{1}{4}x^2 + \frac{1}{2}x + \frac{3}{8}$. (iv) $y + 2 = e^{x-2}$.
14. (i) $y = x \log x + Ax + B$. (ii) $y = (x - 2) e^x + Ax + B$.
15. (i) $y = \log \sec x + Ax + B$. (ii) $C_1^2 y^2 = a + (C_2 \pm C_1^2 x)^2$.
16. $(\sin y + C e^x)(\sin y + C e^{-x}) = 0$.
17. (i) $3x = 2 (\sqrt{y - 2C_1})(\sqrt{y + C_1})^{\frac{1}{2}} + C_2$.
 (ii) $\sqrt{C_1 y^2 + y} - \frac{1}{\sqrt{C_1}} \log (\sqrt{C_1 y} + \sqrt{1 + C_1 y}) = a C_1 \sqrt{2x + C_2}$.
18. (i) $y = C_1 + C_2 x + (6 - x^2) \sin x - 4x \cos x$.
 (ii) $x = \frac{1}{4} e^{2t} + C_1 t + C_2$. 19. (i) $y = \frac{1}{3} A x^3 + B$.
 (ii) $a \log (y + B) = x + C$. 20. $y = C_1 e^{-x} + C_2 + \frac{1}{2} e^x$.
21. $y = \log (1 + x^2) + A \tan^{-1} x + B$. 22. $y = e^{A \sin x + B \cos x}$.
23. $e^x (C_1 - e^y) = C_2$. 24. $e^y (C_1 x + C_2) = 1$.
25. $y^2 = 2x^2 + C_1 x + C_2$. 26. $y = C_1 e^x + C_2 e^{-x} + C_3 x + C_4$.

17·8. Equation of the n th order.

The linear differential equation of the n th order with constant coefficients is

$$\frac{d^n y}{dx^n} + P_1 \frac{d^{n-1} y}{dx^{n-1}} + \dots + P_{n-1} \frac{dy}{dx} + P_n y = X \quad \dots (1)$$

or, symbolically $(D^n + P_1 D^{n-1} + P_2 D^{n-2} + \dots + P_n)y = X$ (2)

or more briefly $f(D)y = X$, ... (3)

where P_1, P_2, \dots, P_n are constants, and X is a function of x only, or a constant.

The method adopted in the case of the solution of the second order equation admits of easy extension to the above case. Thus, the general solution of (1) consists of two parts (i) *the Complementary Function* and (ii) *the Particular Integral*, the complementary function being the general solution of

$$f(D)y = 0 \quad \dots \quad \dots (4)$$

and the particular integral being the value of $\frac{1}{f(D)} X$.

Assuming as before $y = e^{mx}$ as a trial solution of (4), we shall find that $y = e^{mx}$ will be a solution of (4),

$$\text{if } f(m) = 0, \text{ i.e., if } m^n + P_1 m^{n-1} + \dots + P_n = 0. \quad \dots (5)$$

Equation (5) is then the auxiliary equation of (4).

If the auxiliary equation (5) has n real and distinct roots viz., m_1, m_2, \dots, m_n , then the complete solution of (4) is

$$y = C_1 e^{m_1 x} + C_2 e^{m_2 x} + \dots + C_n e^{m_n x}.$$

If the auxiliary equation has a *multiple real root of order r* , and if this root be α , then $f(D)$ contains $(D - \alpha)^r$ as a

factor, and the corresponding part of the complementary function will be the solution of $(D - a)^r y = 0$.

Assuming, as before, $y = e^{ax}v$,

$$(D - a)^r y = (D - a)^r e^{ax}v = e^{ax} D^r v$$

and the solution of $D^r v = 0$, is by successive integration

$$v = (C_0 + C_1 x + C_2 x^2 + \dots + C_{r-1} x^{r-1}),$$

whence, $y = (C_0 + C_1 x + C_2 x^2 + \dots + C_{r-1} x^{r-1}) e^{ax}$

is the corresponding part of the complementary function.

If the auxiliary equation has *complex roots* $a \pm i\beta$, the corresponding part of the solution is, as before

$$y = e^{ax} (A \cos \beta x + B \sin \beta x),$$

and if $a \pm i\beta$ are *double roots of the auxiliary equation*, the corresponding part of the solution will be

$$e^{ax} [(A_1 + A_2 x) \cos \beta x + (B_1 + B_2 x) \sin \beta x].$$

The method of obtaining the particular integral of (1) when X has those special forms [See *Art. 17.5*] is essentially the same as shown in the case of the second order equations.

17.9. Illustrative Examples.

Ex. 1. Solve $(D^3 + 3D^2 + 3D + 1)y = e^{-x}$.

Here the auxiliary equation is $m^3 + 3m^2 + 3m + 1 = 0$ of which the roots are $-1, -1, -1$. \therefore C.F. = $e^{-x} (C_0 + C_1 x + C_2 x^2)$.

$$\begin{aligned} \text{P. I.} &= \frac{1}{(D^3 + 3D^2 + 3D + 1)} \cdot e^{-x} = \frac{1}{(D + 1)^3} e^{-x} \\ &= e^{-x} \cdot \frac{1}{(D - 1 +)^3} \cdot 1 = e^{-x} \frac{1}{D^2} \cdot 1 = e^{-x} \cdot \frac{1}{6} x^3. \end{aligned}$$

\therefore the general solution is $y = e^{-x} (C_0 + C_1 x + C_2 x^2 + \frac{1}{6} x^3)$.

Ex. 2. Solve $(D^4 + 2D^3 + 3D^2 + 2D + 1)y = xe^x$.

The equation can be written as

$$(D^2 + D + 1)^2 y = xe^x.$$

Here, the auxiliary equation is $(m^2 + m + 1)^2 = 0$, it has double complex roots, $-\frac{1}{2} \pm i\frac{1}{2}\sqrt{3}$, $-\frac{1}{2} \pm i\frac{1}{2}\sqrt{3}$.

\therefore C. F. is $e^{-\frac{1}{2}x} [(A_1 + A_2x) \cos (\frac{1}{2}\sqrt{3}x) + (B_1 + B_2x) \sin (\frac{1}{2}\sqrt{3}x)]$.

$$\begin{aligned} \therefore P. I. &= \frac{1}{(D^2 + D + 1)^2} xe^x = e^x \frac{1}{\{(D+1)^2 + (D+1) + 1\}^2} x \\ &= e^x \frac{1}{(D^2 + 3D + 3)^2} x = e^x \cdot \frac{1}{9} \left[\frac{1}{\{1 + D(1 + \frac{1}{3}D)\}^2} \right] x \\ &= e^x \cdot \frac{1}{9} \cdot \{1 + D(1 + \frac{1}{3}D)\}^{-2} x = e^x \cdot \frac{1}{9} \{1 - 2D + \dots + \dots\} x \\ &= \frac{1}{9} e^x (x - 2). \end{aligned}$$

\therefore the general solution is

$$e^{-\frac{1}{2}x} [(A_1 + A_2x) \cos (\frac{1}{2}\sqrt{3}x) + (B_1 + B_2x) \sin (\frac{1}{2}\sqrt{3}x)] + \frac{1}{9} e^x (x - 2).$$

Ex. 3. Solve $\frac{d^5 y}{dx^5} - 2\frac{d^4 y}{dx^4} + y = \sin (2x + 3)$.

The equation can be written as

$$(D^5 - 1)^2 y = \sin (2x + 3).$$

The auxiliary equation is $(m^5 - 1)^2 = 0$; its roots are 1, 1, -1, -1, i , i , $-i$, $-i$. Hence,

$$\begin{aligned} \text{C. F. is } e^x (A_1 + A_2x) + e^{-x} (B_1 + B_2x) \\ + (C_1 + C_2x) \cos x + (D_1 + D_2x) \sin x. \quad \dots (1) \end{aligned}$$

$$\begin{aligned} P. I. &= \frac{1}{(D^5 - 1)^2} \sin (2x + 3) = \frac{1}{\{(-2^5) - 1\}^2} \sin (2x + 3) \\ &= \frac{1}{225} \sin (2x + 3). \quad \dots (2) \end{aligned}$$

Adding (1) and (2), we get the general solution.

EXAMPLES XVII(C)

Solve :—

$$1. \text{ (i) } \frac{d^3 y}{dx^3} - y = 0. \quad [C. P. 1946] \quad \text{(ii) } \frac{d^4 y}{dx^4} - y = 0.$$

$$2. \text{ (i) } \frac{d^3 y}{dx^3} - 3 \frac{dy}{dx} + 2y = 0. \quad [C. P. 1940]$$

$$\text{(ii) } \frac{d^3 y}{dx^3} - \frac{d^2 y}{dx^2} - 2 \frac{dy}{dx} = 0.$$

$$\text{(iii) } \frac{d^4 y}{dx^4} + 4 \frac{d^3 y}{dx^3} + 8 \frac{d^2 y}{dx^2} + 8 \frac{dy}{dx} + 4y = 0.$$

$$\text{(iv) } (D + 1)^3 (D^2 + 1)y = 0.$$

$$3. \text{ (i) } \frac{d^3 y}{dx^3} - y = x^3 - x^2. \quad \text{(ii) } \frac{d^3 y}{dx^3} + \frac{d^2 y}{dx^2} = x^2.$$

$$4. \text{ (i) } (D^3 - D)y = e^x + e^{-x}.$$

$$\text{(ii) } (D^3 - 1)y = \sin(3x + 1).$$

$$5. \frac{d^3 y}{dx^3} - 4 \frac{d^2 y}{dx^2} + 5 \frac{dy}{dx} - 2y = 0.$$

$$6. (D^3 + D^2 - D - 1)y = \sin^2 x.$$

$$7. \frac{d^3 y}{dx^3} - 3 \frac{d^2 y}{dx^2} + 4y = e^{3x}.$$

$$8. \frac{d^3 y}{dx^3} - 2 \frac{dy}{dx} + 4y = e^x \sin \frac{x}{2}.$$

$$9. (D^3 - 3D^2 + 4D - 2)y = e^x + \cos x.$$

$$10. (D^4 - 4D^3 + 3D^2 + 4D - 4)y = e^{2x}$$

$$11. (D^4 + 1)y = 2 \cos^2 \frac{1}{2}x - 1 + e^{-x}.$$

$$12. (D^4 + 2D^2 + 1)y = \cos x.$$

$$13. (D - 1)^2 (D^2 + 1)^2 y = e^x + \sin^2 \frac{1}{2}x.$$

14. $\frac{d^3y}{dx^3} - 2\frac{d^2y}{dx^2} + \frac{dy}{dx} = e^{2x} + x.$

15. $\frac{d^4y}{dx^4} + 5\frac{d^2y}{dx^2} + 4y = 360 \sin \frac{7}{2}x \cos \frac{x}{2}.$

ANSWERS

1. (i) $y = Ae^x + e^{-\frac{1}{2}x} (B \sin \frac{1}{2} \sqrt{3}x + C \cos \frac{1}{2} \sqrt{3}x).$

(ii) $y = Ae^x + Be^{-x} + C \cos x + D \sin x.$

2. (i) $y = e^x (A + Bx) + Ce^{-2x}.$

(ii) $y = A + Be^{3x} + Ce^{-x}.$

(iii) $y = e^{-x} [(A + Bx) \cos x + (C + Dx) \sin x].$

(iv) $y = e^{-x} (A + Bx + Cx^2) + D \cos x + E \sin x.$

3. (i) $y = Ae^x + e^{-\frac{x}{2}} (B \sin \frac{1}{2} \sqrt{3}x + C \cos \frac{1}{2} \sqrt{3}x) - x^3 + x^2 - 6.$

(ii) $y = A + Bx + Ce^{-x} + \frac{1}{12}x^4 - \frac{1}{3}x^3 + x^2.$

4. (i) $y = A + Be^x + Ce^{-x} + \frac{1}{2}x (e^x + e^{-x}).$

(ii) $y = e^{-\frac{1}{2}x} \left(A \cos \frac{\sqrt{3}}{2}x + B \sin \frac{\sqrt{3}}{2}x \right) + Ce^x$
 $+ \frac{27}{35} \cos (3x+1) - \frac{7}{35} \sin (3x+1).$

5. $y = (A_1 + A_2x) e^x + A_3 e^{2x}.$

6. $y = C_1 e^x + (C_2 + C_3x) e^{-x} + \frac{1}{15} \sin 2x + \frac{1}{15} \cos 2x - \frac{1}{2}.$

7. $y = e^{2x} (C_1 + C_2x) + C_3 e^{-x} + \frac{1}{4} e^{3x}.$

8. $y = C_1 e^{-2x} + e^x (C_2 \cos x + C_3 \sin x) - \frac{1}{11} e^x \left(\frac{1}{2} \cos \frac{1}{2}x - 3 \sin \frac{1}{2}x \right).$

9. $y = e^x (C_1 + C_2 \cos x + C_3 \sin x) + xe^x + \frac{1}{10} (\cos x + 3 \sin x).$

10. $y = (C_1 + C_2x) e^{2x} + C_3 e^x + C_4 e^{-x} + \frac{1}{8} x^2 e^{2x}.$

11. $y = e^{-ax} [C_1 \cos ax + C_2 \sin ax] + e^{ax} [C_3 \cos ax + C_4 \sin ax]$
 $+ \frac{1}{2} (\cos x + e^{-x})$ where $a = 1/\sqrt{2}.$

12. $y = (C_1 + C_2x) \sin x + (C_3 + C_4x) \cos x - \frac{1}{3} x^2 \cos x.$

13. $y = (C_1 + C_2x) e^x + (C_3 + C_4x) \cos x + (C_5 + C_6x) \sin x$
 $+ \frac{1}{8} e^x x^2 + \frac{1}{2} - \frac{1}{3} x^2 \sin x.$

14. $y = (C_1 + C_2x) e^x + C_3 + \frac{1}{2} e^{2x} + \frac{1}{2} x^2 + 2x.$

15. $y = C_1 \cos x + C_2 \sin x + C_3 \cos 2x + C_4 \sin 2x + \sin 4x + \frac{1}{2} \sin 8x.$

17·10. Homogeneous Linear Equation.

An equation of the form

$$x^n \frac{d^n y}{dx^n} + P_1 x^{n-1} \frac{d^{n-1} y}{dx^{n-1}} + \dots + P_{n-1} x \frac{dy}{dx} + P_n y = X \quad \dots (1)$$

or, symbolically, $(x^n D^n + P_1 x^{n-1} D^{n-1} + \dots + P_{n-1} x D + P_n) y = X,$ $\dots (2)$

where P_1, P_2, \dots, P_n are constants and X is a function of x alone, is called a *homogeneous linear equation*.

The *substitution*

$$x = e^z, \text{ i.e., } z = \log x,$$

will transform the above equation into an equation with *constant coefficients*, which has already been discussed in Art. 17·8. Here the independent variable will be z .

Now, $\frac{dy}{dx} = \frac{dy}{dz} \cdot \frac{dz}{dx} = \frac{1}{x} \frac{dy}{dz} \quad \dots \dots (3)$

$$\begin{aligned} \frac{d^2 y}{dx^2} &= \frac{d}{dx} \left(\frac{1}{x} \frac{dy}{dz} \right) = -\frac{1}{x^2} \frac{dy}{dz} + \frac{1}{x} \frac{d^2 y}{dz^2} \cdot \frac{1}{x} \\ &= \frac{1}{x^2} \left(\frac{d^2 y}{dz^2} - \frac{dy}{dz} \right) \quad \dots (4) \end{aligned}$$

Similarly, $\frac{d^3 y}{dx^3} = \frac{1}{x^3} \left(\frac{d^3 y}{dz^3} - 3 \frac{d^2 y}{dz^2} + 2 \frac{dy}{dz} \right).$ $\dots (5)$

Let us write δ for $\frac{d}{dz}$; with this notation, (3), (4), (5) can be written as

$$x \frac{dy}{dx} = \delta y. \quad \dots \dots (6)$$

$$x^2 \frac{d^2 y}{dx^2} = \delta(\delta - 1)y \quad \dots \quad (7)$$

$$x^3 \frac{d^3 y}{dx^3} = \delta(\delta - 1)(\delta - 2)y \quad \dots \quad (8)$$

$$x^n \frac{d^n y}{dx^n} = \delta(\delta - 1)(\delta - 2)\dots(\delta - n + 1)y \quad \dots \quad (9)$$

Note. This is sometimes called *Cauchy equation*.

17.11. Equation reducible to the Homogeneous Linear form.

An equation of the form

$$(ax + b)^n \frac{d^n y}{dx^n} + P_1(ax + b)^{n-1} \frac{d^{n-1} y}{dx^{n-1}} + \dots + P_{n-1}(ax + b) \frac{dy}{dx} + P_n y = X \dots \quad (10)$$

where P_1, P_2, \dots, P_n are constants and X is a function of x alone can be reduced to a linear equation with constant coefficients by the substitution $ax + b = z$.

Note. This is sometimes called *Legendre equation*.

17.12. Illustrative Examples.

Ex. 1. Solve $x^3 \frac{d^3 y}{dx^3} - x^2 \frac{d^2 y}{dx^2} + 2x \frac{dy}{dx} - 2y = x^2$.

Put $x = e^z$ i.e., $z = \log x$.

Then by Art. 17.10, the equation transforms into

$$[\delta(\delta - 1)(\delta - 2) - \delta(\delta - 1) + 2\delta - 2] y = e^{2z} \quad \dots \quad (1)$$

where $\delta = \frac{d}{dz}$, or, $(\delta - 1)^2(\delta + 2)y = e^{2z}$.

\therefore the roots of auxiliary equation are 1, 1, -2.

The C. F. is $y = (C_1 + C_2 z) e^z + C_3 e^{-2z}$.

And P. I. is $\frac{1}{(\delta - 1)^2(\delta + 2)} e^{2z} = \frac{1}{2} e^{2z}$.

∴ the general solution of (1) is

$$y = (C_1 + C_2 z) e^z + C_3 e^{-2z} + \frac{1}{4} e^{2z}.$$

Hence, the general solution of the given equation is

$$y = (C_1 + C_2 \log x) x + C_3 x^{-2} + \frac{1}{4} x^2.$$

Ex. 2. Solve $(x^2 D^2 + 2xD) y = xe^x$.

Put $x = e^z$ i.e., $z = \log x$.

∴ by Art. 17·10, the equation transforms into

$$\{\delta(\delta - 1) + 2\delta\}y = e^z e^{e^z} \quad \dots (1)$$

where $\delta = \frac{d}{dz}$, or, $(\delta^2 + \delta)y = e^z e^{e^z}$.

∴ the roots of the auxiliary equation are 0, -1.

∴ the C. F. is $y = C_1 + C_2 e^{-z}$.

$$\begin{aligned} \text{P. I.} &= \frac{1}{\delta(\delta + 1)} \cdot e^z e^{e^z} \\ &= \left(\frac{1}{\delta} - \frac{1}{\delta + 1} \right) e^z e^{e^z} \\ &= \frac{1}{\delta} e^z e^{e^z} - \frac{1}{\delta + 1} e^z e^z \\ &= \int e^z e^{e^z} dz - e^{-z} \int e^{-z} e^z dz \quad [\text{By Art. 17·5(1)}] \end{aligned}$$

Put $e^z = y$.

$$\text{P. I.} = e^{e^z} - e^{-z} \{(e^z - 1) e^{e^z}\} = e^{-z} e^{e^z} \quad [\text{See Ex. 8, of Art. 17·6}]$$

∴ the general solution of (1) is

$$y = C_1 + C_2 e^{-z} + e^{-z} e^{e^z}.$$

Hence the general solution of the given equation is

$$y = C_1 + C_2 x^{-1} + x^{-1} e^x.$$

EXAMPLES XVII(D)

Solve the following equations :—

$$1. \quad x^2 \frac{d^2 y}{dx^2} - 4x \frac{dy}{dx} + 6y = x.$$

$$2. \quad (x^2 D^2 + xD - 1) y = \sin(\log x) + x \cos(\log x).$$

3. $x^2 \frac{d^2 y}{dx^2} + 5x \frac{dy}{dx} + 4y = x^4.$
4. $(x^2 D^2 - 2) y = x^2 + \frac{1}{x}.$
5. $x^3 \frac{d^3 y}{dx^3} + 2x^2 \frac{d^2 y}{dx^2} - 2x \frac{dy}{dx} = 0.$
6. $(x^3 D^3 + xD - 1) y = x^2.$
7. $x^3 \frac{d^3 y}{dx^3} + x \frac{dy}{dx} - y = x.$
8. $(x + 2)^2 \frac{d^2 y}{dx^2} - 4(x + 2) \frac{dy}{dx} + 6y = x.$
9. $(x^4 D^4 + 6x^3 D^3 + 9x^2 D^2 + 3xD + 1) y = 0.$
10. $x^4 \frac{d^3 y}{dx^3} + 3x^3 \frac{d^2 y}{dx^2} - 2x^2 \frac{dy}{dx} + 2xy = \log x.$

ANSWERS

1. $y = C_1 x^2 + C_2 x^3 + \frac{1}{2} x.$
2. $y = C_1 x + C_2 x^{-1} - \frac{1}{2} \sin (\log x) + \frac{x}{5} \{2 \sin (\log x) - \cos (\log x)\}.$
3. $y = (C_1 + C_2 \log x) x^{-2} + \frac{1}{36} x^4.$
4. $y = C_1 x^{-1} + C_2 x^2 + \frac{1}{3} x^2 \log x - \frac{1}{3} x^{-1} \log x$
5. $y = C_1 x^2 + C_2 x^{-1} + C_3.$
6. $y = \{C_1 + C_2 \log x + C_3 (\log x)^2\} x + x^3.$
7. $y = \{C_1 + C_2 \log x + C_3 (\log x)^2\} x + \frac{1}{6} x (\log x)^2.$
8. $y = C_1 (x+2)^2 + C_2 (x+2)^3 + \frac{1}{6} (3x+4).$
9. $y = (C_1 + C_2 \log x) \cos (\log x) + (C_3 + C_4 \log x) \sin (\log x).$
10. $y = (C_1 + C_2 \log x) x + C_3 x^{-2} + \frac{1}{4} x^{-1} \log x.$

CHAPTER XVIII

APPLICATIONS

18·1. We have already considered in the preceding chapters some applications of differential equations to geometrical problems. Here we shall have some other applications of differential equations.

18·2. Orthogonal Trajectories.

If every member of a family of curves cuts the members of a given family at right angles, each family is said to be a set of *orthogonal trajectories* of the other.

(A) Rectangular Co-ordinates.

Suppose we have one-parameter family of curves

$$f(x, y, c) = 0, \quad \dots \quad (1)$$

c being the variable parameter.

Let us first form the differential equation of the family by differentiation of (1) with respect to x and by elimination of c [See *Art. 14·2*] and let the differential equation be

$$\phi \left(x, y, \frac{dy}{dx} \right) = 0. \quad \dots \quad (2)$$

If the two curves cut at right angles, and if ψ, ψ' be the angles which the tangents to the given curve and the trajectory at the common point of intersection, (say x, y), make with the x -axis, we have $\psi \sim \psi' = \frac{1}{2}\pi$, and therefore, $\tan \psi = -\cot \psi'$. Since $\tan \psi = \frac{dy}{dx}$, it follows that the

differential equation of the system of trajectories is obtained by substituting $-1 \left/ \frac{dy}{dx} \right.$, i.e., $-\frac{dx}{dy}$ for $\frac{dy}{dx}$ in (2).

Thus, *the differential equation of the system of orthogonal trajectories is*

$$\phi \left(x, y, -\frac{dx}{dy} \right) = 0. \quad \dots (3)$$

Integrating (3) we shall get the equation in the ordinary form.

(B) Polar Co-ordinates.

Suppose the equation of a given one-parameter family of curves be

$$f(r, \theta, c) = 0 \quad \dots (1)$$

and the corresponding differential equation, obtained by eliminating the arbitrary parameter c , be

$$F \left(r, \theta, \frac{dr}{d\theta} \right) = 0. \quad \dots (2)$$

If ϕ, ϕ' denote the angles which the tangents to the given curve and the trajectory at the common point of intersection, (say r, θ), make with the radius vector to the common point, we have as before $\tan \phi = -\cot \phi'$.

Since $\tan \phi = r \frac{d\theta}{dr}$, it follows that the differential equation of the system of orthogonal trajectories is obtained by substituting $-\frac{1}{r} \frac{dr}{d\theta}$ for $r \frac{d\theta}{dr}$, i.e., $-r^2 \frac{d\theta}{dr}$ for $\frac{dr}{d\theta}$ in (2).

Hence, *the differential equation of the required system of orthogonal trajectories is*

$$F \left(r, \theta, -r^2 \frac{d\theta}{dr} \right) = 0. \quad \dots (3)$$

Integrating (3) we shall get the equation in the ordinary form.

Ex. 1. Find the orthogonal trajectories of the rectangular hyperbolas $xy = a^2$.

Differentiating $xy = a^2$ with respect to x , we have the differential equation of the family of curves

$$x \frac{dy}{dx} + y = 0 \quad \dots \quad \dots \quad (1)$$

and hence for the orthogonal trajectories, the differential equation is

$$-x \frac{dx}{dy} + y = 0, \text{ or, } x dx - y dy = 0.$$

Integrating this, we have, $x^2 - y^2 = c^2$, the required equation of the orthogonal trajectories. It represents a system of rectangular hyperbolas.

Ex. 2. Find the orthogonal trajectories of the cardioides

$$r = a(1 - \cos \theta).$$

Since, $r = a(1 - \cos \theta)$, $\therefore \log r = \log a + \log(1 - \cos \theta)$.

Differentiating with respect to θ , we get the differential equation of the family of curves

$$\frac{1}{r} \frac{dr}{d\theta} = \frac{\sin \theta}{1 - \cos \theta}.$$

\therefore the differential equation of the system of orthogonal trajectories is

$$\frac{1}{r} \left(-r^2 \frac{d\theta}{dr} \right) = \frac{\sin \theta}{1 - \cos \theta},$$

$$\text{or, } \frac{dr}{r} + \frac{1 - \cos \theta}{\sin \theta} d\theta = 0,$$

$$\text{or, } \frac{dr}{r} + \frac{\sin \theta}{1 + \cos \theta} d\theta = 0.$$

\therefore integrating, $\log \frac{r}{1 + \cos \theta} = \log c$;

$$\text{i.e., } r = c(1 + \cos \theta),$$

represents the required orthogonal trajectories.

Ex. 3. Find the orthogonal trajectories of the system of curves

$$r^n = a^n \cos n\theta.$$

Since $r^n = a^n \cos n\theta$, $\therefore n \log r = n \log a + \log \cos n\theta$.

Differentiating with respect to θ , (and thereby eliminating a), we get the differential equation of the family of curves

$$n \frac{1}{r} \frac{dr}{d\theta} = -n \frac{\sin n\theta}{\cos n\theta}.$$

\therefore the differential equation of the system of orthogonal trajectories is

$$\frac{1}{r} \left(-r^2 \frac{d\theta}{dr} \right) = -\frac{\sin n\theta}{\cos n\theta}.$$

$$\therefore \frac{dr}{r} - \frac{\sin n\theta}{\cos n\theta} d\theta = 0.$$

\therefore integrating, $\log r - \frac{1}{n} \log \sin n\theta = \log c$

$$\text{i.e., } \log \frac{r}{(\sin n\theta)^{\frac{1}{n}}} = \log c$$

$\therefore r^n = c^n \sin n\theta.$

18.3. Velocity and acceleration of a moving particle.

If a particle be moving along a straight line, and if at any instant t , the position P of the particle be given by the distance s measured along the path from a suitable fixed point A on it, then v denoting the velocity, and f the acceleration of the particle at the instant, we have

$$\begin{aligned} v &= \text{rate of displacement} \\ &= \text{rate of change of } s \text{ with respect to time} \\ &= \frac{ds}{dt} \end{aligned}$$

and, $f = \text{rate of change of velocity with respect to time}$

$$= \frac{dv}{dt} = \frac{d^2s}{dt^2}.$$

If instead of moving in a straight line, the particle be moving in any manner in a plane, the position of the particle at any instant t being given by the cartesian co-ordinates x, y , referred to a fixed set of axes, the components of velocity and acceleration parallel to these axes will similarly be given by

$$v_x = \text{rate of displacement parallel to } x\text{-axis} = \frac{dx}{dt}$$

$$v_y = \text{rate of displacement parallel to } y\text{-axis} = \frac{dy}{dt}$$

$$f_x = \text{rate of change of } v_x = \frac{d}{dt} \left(\frac{dx}{dt} \right) = \frac{d^2x}{dt^2}$$

$$f_y = \text{rate of change of } v_y = \frac{d}{dt} \left(\frac{dy}{dt} \right) = \frac{d^2y}{dt^2}.$$

The applications of these results are illustrated in the following examples.

Ex. 1. *A particle starting with velocity u , moves in a straight line with a uniform acceleration f . Find the velocity and distance travelled in any time.*

s denoting the distance travelled by the particle in time t , the acceleration of the particle is given by the expression $\frac{d^2s}{dt^2}$, and so in this case, $\frac{d^2s}{dt^2} = f$; \therefore integrating, $\frac{ds}{dt} = ft + A$, where A is the integration constant. Now, $\frac{ds}{dt}$ is the expression for the velocity v of the particle at time t , and when $t = 0$, i.e., at start, $v = u$. $\therefore u = 0 + A$.

$$\text{Hence, } v = \frac{ds}{dt} = ft + u. \quad \dots \quad \dots \quad (1)$$

Integrating (i), $s = \frac{1}{2}ft^2 + ut + B$, where the integration constant B is found in this particular case from the fact that $s = 0$ when $t = 0$, $\therefore B = 0$.

$$\text{Hence, } s = \frac{1}{2}ft^2 + ut = ut + \frac{1}{2}ft^2.$$

Ex. 2. *A particle is projected with a velocity u at an angle α to the horizon. Find the path.*

Taking the starting point as the origin, and taking the axes of co-ordinates horizontal and vertical respectively, if x, y denote the co-ordinates of the particle at any time t , since there is no force and therefore no acceleration in the horizontal direction, and since the vertical acceleration is always the same = g downwards, we have in this case

$$\frac{d^2x}{dt^2} = 0, \quad \frac{d^2y}{dt^2} = -g.$$

Hence, integrating,

$$\frac{dx}{dt} = A, \quad \frac{dy}{dt} = -gt + B. \quad \dots \quad (i)$$

But $\frac{dx}{dt}, \frac{dy}{dt}$ represent the horizontal and the vertical component of velocity respectively, and these, at start when $t=0$, are given by $u \cos \alpha$ and $u \sin \alpha$.

$$\therefore u \cos \alpha = A, \quad u \sin \alpha = 0 + B,$$

whereby the integration constants are obtained.

Thus, (i) gives

$$\frac{dx}{dt} = u \cos \alpha, \quad \frac{dy}{dt} = u \sin \alpha - gt.$$

Integrating again, $x = ut \cos \alpha + C$

$$y = ut \sin \alpha - \frac{1}{2}gt^2 + D.$$

Now, since $x = y = 0$ when $t = 0$, we get from above, $C = D = 0$.

Hence, $x = ut \cos \alpha$

$$y = ut \sin \alpha - \frac{1}{2}gt^2.$$

Eliminating t , the path of the particle is given by

$$y = x \tan \alpha - \frac{1}{2}g \frac{x^2}{u^2 \cos^2 \alpha}$$

which is evidently a parabola.

18'4. Miscellaneous Applications.

The examples below will illustrate some other applications of differential equations.

Ex. 1. *The population of a country increases at the rate proportional to the number of inhabitants. If the population doubles in 30 years, in how many years will it treble ?*

Let x be the population in t years.

$$\therefore \frac{dx}{dt} = kx, \quad \therefore \text{ solving, } x = Ce^{kt}.$$

$$\text{Let } x = x_0, \text{ when } t = 0; \quad \therefore C = x_0; \quad \therefore x = x_0 e^{kt}.$$

$$\text{When } x = 2x_0, t = 30; \quad \therefore 2x_0 = x_0 e^{30k}; \quad \therefore 2 = e^{30k}.$$

$$\text{When } x = 3x_0, \text{ let } t = T; \quad \therefore 3x_0 = x_0 e^{kT}; \quad \therefore 3 = e^{kT}.$$

$$\therefore \left. \begin{array}{l} 30k = \log_e 2 \\ \text{and } kT = \log_e 3 \end{array} \right\} \quad \therefore \frac{T}{30} = \frac{\log_e 3}{\log_e 2} = \frac{48}{30} \text{ nearly.}$$

$$\therefore T = 30 \times \frac{48}{30} = 48 \text{ years approximately.}$$

Ex. 2. *After how many years will Rs. 100, placed at the rate of 5% continuously compounded, amount to Rs. 1000 ?*

Let x be the amount in t years.

$$\therefore \frac{dx}{dt} = \frac{5}{100} x = kx \text{ say, where } k = \frac{1}{20}.$$

$$\therefore \text{ solving, } x = Ce^{kt}.$$

$$\text{When } t = 0, x = 100; \quad \therefore C = 100. \quad \therefore x = 100e^{kt}.$$

$$\text{When } x = 1000, \text{ let } t = T. \quad \therefore 1000 = 100e^{kT} \quad \therefore e^{kT} = 10.$$

$$\therefore kT = \log_e 10 = 2.30 \text{ nearly. } \therefore T = \frac{1}{k} \times 2.30 = 20 \times 2.30 = 46 \text{ nearly.}$$

$$\therefore \text{ the reqd. time is 46 years nearly.}$$

EXAMPLES XVIII

Find the orthogonal trajectories of the following families of curves :—

1. (i) $y = mx.$

(ii) $y = ax^n.$

(iii) $x^2 + y^2 = 2ay.$

(iv) $y^2 = 4ax.$

(v) $ay^2 = x^3.$

(vi) $x^2 + 2y^2 = a.$

(vii) $x^{\frac{2}{3}} + y^{\frac{2}{3}} = a^{\frac{2}{3}}.$

(viii) $x^2 + y^2 + a^2 = 1 + 2axy.$

(ix) $r = a \cos \theta.$

(x) $r^2 = a^2 \cos 2\theta.$

(xi) $r(1 + \cos \theta) = 2a.$

(xii) $r^n \sin n\theta = a^n.$

2. (i) Show that the orthogonal trajectories of a system of concurrent straight lines form a system of concentric circles, and conversely.

(ii) Show that the orthogonal trajectories of the system of co-axial circles

$$x^2 + y^2 + 2\lambda x + c = 0$$

form another system of co-axial circles

$$x^2 + y^2 + 2\mu y - c = 0,$$

where λ and μ are parameters and c is a given constant.

(iii) Show that the orthogonal trajectories of the system of circles touching a given straight line at a given point, form another system of circles which pass through the given point and whose centres lie on the given line.

[*Take the point of concurrence as the origin.*]

3. (a) Show that every member of the first set of curves cuts orthogonally every member of the second

$$(i) \frac{dy}{dx} = \frac{x^2 + x + 1}{y^2 + y + 1} \qquad (ii) \frac{dy}{dx} + \frac{y^2 + y + 1}{x^2 + x + 1} = 0.$$

(b) Show that

(i) the family of parabolas $y^2 = 4a(x + a)$ is self-orthogonal.

(ii) the family of confocal conics

$$\frac{x^2}{a^2 + \lambda} + \frac{y^2}{b^2 + \lambda} = 1 \quad (\lambda \text{ being the parameter})$$

is self-orthogonal.

4. (i) Find the curve in which the radius of curvature is proportional to the arc measured from a fixed point, and identify it.

(ii) Find the curve for which the tangent at any point cuts off from the co-ordinate axes intercepts whose sum is constant and identify it.

5. Find the cartesian equation of a curve for which the tangent is of constant length.

6. A particle is said to execute a *Simple Harmonic Motion* when it moves on a straight line, with its acceleration always directed towards a fixed point on the line and proportional to the distance from it in any position. If it starts from rest at a distance a from the fixed point, find its velocity in any position, and the time for that position. Deduce that the motion is oscillatory, and find the periodic time.

7. A particle falls towards the earth, starting from rest at a height h above the surface. If the attraction of the earth varies inversely as the square of the distance from its centre, find the velocity of the particle on reaching the earth's surface, given a the radius of the earth, and g the value of the acceleration due to gravity at the surface of the earth.

8. A particle falls in a vertical line under gravity (supposed constant), and the force of air resistance to its motion is proportional to its velocity. Show that its velocity cannot exceed a particular limit.

9. A particle moves in an ellipse with an acceleration directed towards its centre. Show that the acceleration is proportional to its distance from the centre.

10. In a certain culture, the number of bacteria is increasing at a rate proportional to the number present. If the number doubles in 3 hours, how many may be expected at the end of 12 hours ?

11. After how many years will a sum of money, placed at the rate of 5% continuously compounded, double itself ?

12. Radium disappears at a rate proportional to the amount present. If 5% of the original amount disappears in 50 years, how much will remain at the end of 100 years ?

13. A tank consists of 50 litres of fresh water. Two litres of brine each containing 5 gms. of dissolved salt are run into the tank per minute ; the mixture is kept uniform by stirring, and runs out at the rate of one litre per minute. If m gms. of salt are present in the tank after t minutes, express m in terms of t and find the amount of salt present after 10 minutes.

14. The electric current I through a coil of resistance R and inductance L satisfies the equation $RI + L\frac{dI}{dt} = V$, where V is the potential difference between the two ends of the coil. A potential difference $V = a \sin \omega t$ is applied to the coil from time $t = 0$ to the time $t = \pi/\omega$, where a, ω are positive constants. The current is zero at $t = 0$ and V is zero after $t = \pi/\omega$; find the current at any time both before and after $t = \pi/\omega$.

15. A horizontal beam of length $2l$ ft., carrying a uniform load of w lbs. per foot of length, is freely supported at both ends, satisfying the differential equation

$$EI \frac{d^2 y}{dx^2} = \frac{1}{2}wx^2 - wlx,$$

y being the deflection at a distance x from one end. If $y = 0$ at $x = 0$, and $y_1 = 0$ at $x = l$, find the deflection at any point; also find the maximum deflection.

16. A horizontal beam of length l simply supported at its end subject only to its own weight satisfies the equation

$$EI \frac{d^4 y}{dx^4} = w,$$

where E, I, w are constants. Given $y_2 = y = 0$ at $x = 0$ and at $x = l$, express the deflection y in terms of x .

17. A harmonic oscillator consists of an inductance L , a condenser of capacitance C and an *e.m.f.* E . Find the charge q and the current i when $E = E_0 \cos \omega t$ and initial conditions are $q = q_0$ and $i = i_0$ at $t = 0$, i, q satisfying the equations

$$\frac{d^2 q}{dt^2} + \frac{q}{LC} = \frac{E_0}{L} \cos \omega t, \quad i = \frac{dq}{dt}.$$

What happens if $\omega = \frac{1}{\sqrt{CL}}$?

ANSWERS

1. (i) $x^2 + y^2 = a^2$. (ii) $x^2 + ny^2 = c^2$. (iii) $x^2 + y^2 = 2cx$.
 (iv) $2x^2 + y^2 = c^2$. (v) $2x^2 + 3y^2 = c^2$. (vi) $y = cx^2$.
 (vii) $x^{\frac{4}{3}} - y^{\frac{4}{3}} = c^{\frac{4}{3}}$.
 (viii) $y \sqrt{1-y^2} - x \sqrt{1-x^2} + \sin^{-1}y - \sin^{-1}x = c$.
 (ix) $r = c \sin \theta$. (x) $r^2 = c^2 \sin 2\theta$.
 (xi) $r(1 - \cos \theta) = 2c$. (xii) $r^n \cos n\theta = c$.
4. (i) Equi-angular spiral. (ii) Parabola.
5. $x = \sqrt{a^2 - y^2} + \frac{1}{2}a \{ \log(a - \sqrt{a^2 - y^2}) - \log(a + \sqrt{a^2 - y^2}) \}$,
 if $y = a$, when $x = 0$.
6. $v = \sqrt{\mu(a^2 - x^2)}$, $t = \frac{1}{\sqrt{\mu}} \cos^{-1} \frac{x}{a}$, when μ is the acceleration at
 a unit distance. Period $\frac{2\pi}{\sqrt{\mu}}$.
7. $\sqrt{\frac{2aglh}{a+h}}$. 10. 16 times the original number.
11. 14 years nearly. 12. $\frac{361}{300}$ of the original amount.
13. $5t \left(1 + \frac{50}{50+t} \right)$ gms.; $91\frac{2}{3}$ gms.
14. For $t < \frac{\pi}{\omega}$, $I = \frac{a}{L^2\omega^2 + R^2} \left[R \sin \omega t - \omega L (\cos \omega t - e^{-\frac{Rt}{L}}) \right]$
 and for $t > \frac{\pi}{\omega}$, $I = \frac{a\omega L}{L^2\omega^2 + R^2} \left(1 + e^{\frac{R\pi}{L}} \right) e^{-\frac{Rt}{L}}$.
15. $y = \frac{w}{24EI} (x^4 - 4lx^3 - 8l^2x)$; $y_{max} = \frac{5wl^4}{24EI}$.
16. $y = \frac{w}{24EI} (x^4 - 2lx^3 + l^2x)$.

$$\begin{aligned}
 17. \quad q &= \left(q_0 - \frac{E_0 C}{1 - \omega^2 LC} \right) \cos \frac{1}{\sqrt{LC}} t + \sqrt{LC} i_0 \sin \frac{1}{\sqrt{LC}} t \\
 &\quad + \frac{E_0 C}{1 - \omega^2 LC} \cos \omega t. \\
 i &= i_0 \cos \frac{1}{\sqrt{LC}} t - \frac{1}{\sqrt{LC}} \left(q_0 - \frac{E_0 C}{1 - \omega^2 LC} \right) \sin \frac{1}{\sqrt{LC}} t \\
 &\quad - \frac{E_0 C \omega}{1 - \omega^2 LC} \sin \omega t.
 \end{aligned}$$

If $\omega = \frac{1}{\sqrt{LC}}$ i.e., frequency of *e.m.f.* = natural frequency oscillation i.e., resonance will take place and the circuit will be destroyed. Before destroying

$$\begin{aligned}
 q &= q_0 \cos \omega t + \frac{i_0}{\omega} \sin \omega t + \frac{E_0}{2L\omega} t \sin \omega t \\
 i &= i_0 \cos \omega t - q_0 \omega \sin \omega t + \frac{E_0}{2L} \left(\frac{1}{\omega} \sin \omega t + t \cos \omega t \right).
 \end{aligned}$$

CHAPTER XIX
THE METHOD OF ISOCLINES

19'1. It is only in a limited number of cases that a differential equation may be solved analytically by the preceding methods, and in many practical cases where the solution of a differential equation is needed under given initial conditions, and the above methods fail, a graphical method, the *method of isoclines* is sometimes adopted. We proceed to explain below this method in case of simple differential equations of the first order.

Let us consider an equation of the type

$$\frac{dy}{dx} = f(x, y). \quad \dots \quad \dots \quad (i)$$

As already explained before, the general solution of this equation involves one arbitrary constant of integration, and hence represents a family of curves, and in general, one member of the family passes through a given point (x, y) .

Now, if in (i) we replace $\frac{dy}{dx}$ by m , we get an equation $f(x, y) = m$, which for any particular numerical value of m represents a curve, at every point of which the value of $\frac{dy}{dx}$, i.e., the slope of the tangent line to the family of curves represented by the general solution of (i) is the same as that numerical value of m . This curve $f(x, y) = m$ is called an *isoclinal* or isocline. For different numerical values of m we get different isoclinals, which may be graphically constructed on a graph paper. Through different points on any one isocline, short parallel lines are drawn having their common slope equal to the particular value of m for that isocline. Similar short parallel lines are drawn through points on other isoclinals. If the

number of isoclines drawn be large, so that they are sufficiently close to one another, the short lines will ultimately join up and appear to form a series of curves which represent the family of curves giving the general solution of (i) and a particular member of the family passing through a given point represents the particular solution wanted. All necessary informations regarding the particular solution may now be obtained from the graph.

As an example, let us consider the differential equation $\frac{dy}{dx} = x - y^2$. The isoclinals are given by $m = x - y^2$ or $y^2 = x - m$, a series of equal parabolas shifted left or right

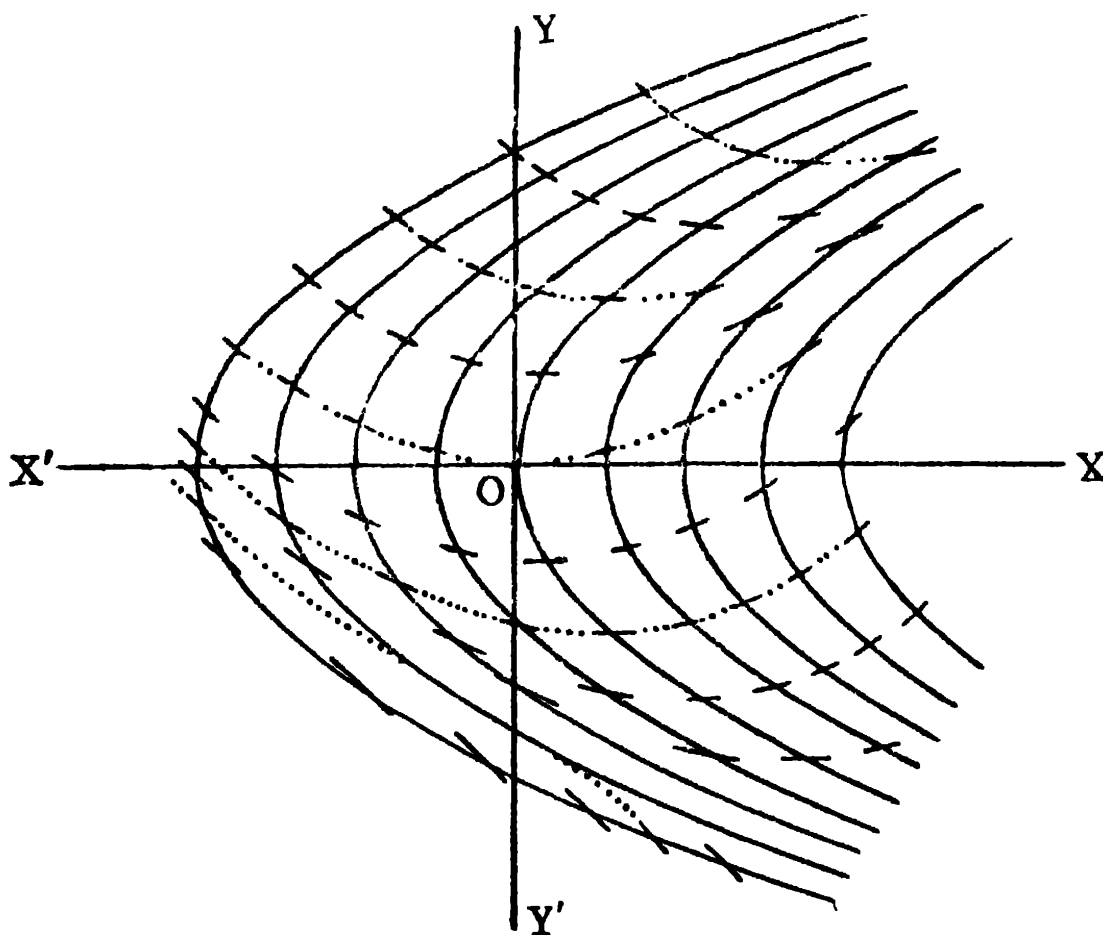

from $y^2 = x$, (which corresponds to $m = 0$) as shown in the figure. The dotted curves represent graphically the solutions of the differential equation.

APPENDIX

SECTION A

A NOTE ON DEFINITE INTEGRALS

1. Definition.

We have *two* methods of defining definite integrals : one based on the *notion of limits*, the other based on the *notion of bounds*.

The first method based on the notion of limits is given in Note 2, Art. 6'2.

The second method based on the notion of bounds is given below.

Let the interval (a, b) be divided in any manner into a number (say n) of sub-intervals by taking intermediate points

$$a = x_0 < x_1 < x_2 \dots \dots < x_{n-1} < x_n = b.$$

Let M_r and m_r be the upper and lower bounds of $f(x)$ in the r -th sub-interval (x_{r-1}, x_r) and let δ_r denote the length of this sub-interval. The lower bound (denoted by \mathbf{J}) of the aggregate of the sums $S = \Sigma M_r \delta_r$ (obtained by considering all possible modes of sub-division), is called the *Upper Integral* and is denoted by $\int_a^b f(x) dx$, and the upper bound (denoted by \mathbf{j}) of the aggregate of the sums $s = \Sigma m_r \delta_r$ is called the *Lower Integral* and is denoted by $\int_a^b f(x) dx$. When the lower and upper integrals are equal, *i.e.*, when $\mathbf{j} = \mathbf{J}$,

then $f(x)$ is said to be *integrable* and the common value is said to be the integral of $f(x)$ in (a, b) and is denoted by $\int_a^b f(x) dx$.

It can be shown by what is known as *Darboux's theorem* that both the definitions are equivalent when $f(x)$ is integrable.

Note. The integral defined above when it exists, is called a Riemann integral, as it was first obtained by the great mathematician Riemann.

2. Necessary and sufficient condition for integrability.

We give below without proof the *necessary and sufficient condition* for the integrability of a bounded function $f(x)$.

If there be at least one pair of sums S, s for $f(x)$ for a sub-division of the interval (a, b) such that

$$S - s < \epsilon,$$

where ϵ is any arbitrarily small positive number, then $f(x)$ is integrable.

Note. It can be easily shown that the sum or difference of two or more functions integrable in (a, b) is also integrable in (b, a) .

3. Integrable functions.

(i) Functions continuous in a closed interval (a, b) are integrable in that interval.

(ii) Functions with only a *finite* number of *finite* discontinuities in a closed interval (a, b) are integrable in that interval.

(iii) Functions *monotonic and bounded* in an interval (a, b) are integrable in that interval.

4. Important Theorems.

I. If $f(x)$ is integrable in the closed interval (a, b) and if $f(x) \geq 0$ for all x in (a, b) , then $\int_a^b f(x) dx \geq 0$ ($b > a$).

Since, $f(x) \geq 0$ in (a, b) , it follows that in the interval (x_{r-1}, x_r) the lower bound $m_r \geq 0$ and therefore

$$s = \sum m_r \delta_r \geq 0$$

$\therefore j$, which is the upper bound of the set of numbers s , ≥ 0 .

Since, $f(x)$ is integrable, $j = \int_a^b f(x) dx$

$$\text{and hence } \int_a^b f(x) dx \geq 0.$$

Alternatively.

Since, $f(x)$ is integrable in (a, b) ,

$$\therefore \int_a^b f(x) dx = \lim_{n \rightarrow \infty} \sum f(\xi_r) \delta_r.$$

Since, $f(x) \geq 0$ in (a, b) , $\therefore f(\xi_r) \geq 0$ in (a, b) .

$$\therefore \lim_{n \rightarrow \infty} \sum f(\xi_r) \delta_r \geq 0 \text{ in } (a, b).$$

$$\therefore \int_a^b f(x) dx \geq 0 \text{ in } (a, b).$$

Note. It can be shown similarly that if $f(x) \leq 0$ in (a, b) , then $\int_a^b f(x) dx \leq 0$.

II. If $f(x)$ and $g(x)$ are integrable in (a, b) and $f(x) \geq g(x)$ in (a, b) , then $\int_a^b f(x) dx \geq \int_a^b g(x) dx$ ($b > a$).

Consider the function $\psi(x) \equiv f(x) - g(x)$.

Then $\psi(x)$ is integrable in (a, b) and $\psi(x) \geq 0$ in (a, b) .

$$\therefore \text{ by (i), } \int_a^b \psi(x) dx \geq 0 \text{ in } (a, b)$$

$$\text{i.e., } \int_a^b \{f(x) - g(x)\} dx \geq 0 \text{ in } (a, b)$$

$$\text{i.e., } \int_a^b f(x) dx \geq \int_a^b g(x) dx.$$

III. If M and m are the upper and lower bounds of the integrable function $f(x)$ in (a, b) , $b > a$, then

$$m(b-a) \leq \int_a^b f(x) dx \leq M(b-a).$$

Since, $m \leq f(x) \leq M$ in (a, b) ,

$$\therefore \{f(x) - m\} \geq 0 \text{ in } (a, b),$$

$$\therefore \int_a^b \{f(x) - m\} dx \geq 0.$$

$$\therefore \int_a^b f(x) dx \geq m \int_a^b dx, \text{ i.e., } \geq m(b-a).$$

Similarly, since, $M - f(x) \geq 0$, we can show

$$M(b-a) \geq \int_a^b f(x) dx.$$

Hence the result.

This is known as the *First Mean Value Theorem of Integral Calculus*.

Cor. The above theorem can be written in the form

$$\int_a^b f(x) dx = (b-a) \mu, \text{ when } m \leq \mu \leq M;$$

and if further $f(x)$ is *continuous* in (a, b) then $f(x)$ attains the value μ for some value ζ of x such that $a \leq \zeta \leq b^*$, and so,

$$\int_a^b f(x) dx = (b-a) f(\zeta).$$

*See Authors' Differential Calculus.

IV. If $f(x)$ and $g(x)$ are integrable in (a, b) and if $g(x)$ maintains the same sign throughout (a, b) , then

$$\int_a^b f(x) g(x) dx = \mu \int_a^b g(x) dx, \text{ where } m \leq \mu \leq M,$$

m and M being the lower and upper bounds of $f(x)$ in (a, b) .

Let us assume for the sake of definiteness that $g(x)$ is always positive in (a, b) .

Now, $m \leq f(x) \leq M$ in (a, b) .

Since, $g(x)$ is positive

$$\therefore mg(x) \leq f(x) g(x) \leq Mg(x),$$

$$\therefore f(x) g(x) - mg(x) \geq 0,$$

$$\therefore \int_a^b \{f(x) g(x) - mg(x)\} dx \geq 0.$$

$$\therefore \int_a^b f(x) g(x) dx \geq m \int_a^b g(x) dx$$

$$\text{and } f(x) g(x) - Mg(x) \leq 0,$$

$$\therefore \int_a^b \{f(x) g(x) - Mg(x)\} dx \leq 0$$

$$\text{i.e., } \int_a^b f(x) g(x) dx \leq M \int_a^b g(x) dx.$$

$$\therefore m \int_a^b g(x) dx \leq \int_a^b f(x) g(x) dx \leq M \int_a^b g(x) dx,$$

$$\therefore \int_a^b f(x) g(x) dx = \mu \int_a^b g(x) dx, \text{ where } m \leq \mu \leq M.$$

Cor. If further $f(x)$ is continuous, then $f(x)$ attains the value μ for some value ζ of x where $a \leq \zeta \leq b$, i.e., $f(\zeta) = \mu$.

\therefore when $f(x)$ is continuous,

$$\int_a^b f(x) g(x) dx = f(\zeta) \int_a^b g(x) dx.$$

Note. This is the *generalised form of the First Mean Value Theorem*. The theorem III can be obtained from this by putting $g(x)=1$.

V. If $f(t)$ is bounded and integrable in the closed interval (a, b) and if $F(x) = \int_a^x f(t) dt$ where x is any point in (a, b) , then

(1) $F(x)$ is a continuous function of x in (a, b) .

(2) If $f(x)$ is continuous throughout (a, b) then the derivative of $F(x)$ exists at every point of (a, b) and $=f(x)$.

(3) If $f(x)$ is continuous throughout (a, b) and if $\phi(x)$ be a function of x such that $\phi'(x) = f(x)$ throughout (a, b) , then

$$F(x) = \int_a^x f(t) dt = \phi(x) - \phi(a).$$

(1) Let us consider a point $x+h$ in the neighbourhood of x in (a, b) .

$$\text{Then } F(x+h) = \int_a^{x+h} f(t) dt.$$

$$\begin{aligned} \therefore F(x+h) - F(x) &= \int_a^{x+h} f(t) dt - \int_a^x f(t) dt \\ &= \int_x^{x+h} f(t) dt = \mu h, \end{aligned}$$

by Cor. of (III) where μ lies between the upper and lower bounds of $f(t)$ in the interval $(x, x+h)$. Since $f(t)$ is integrable, m and M are finite and so is μ .

$$\therefore \lim_{h \rightarrow 0} \{F(x+h) - F(x)\} = \lim_{h \rightarrow 0} \mu h = 0.$$

$$\therefore \lim_{h \rightarrow 0} F(x+h) = F(x).$$

$\therefore F(x)$ is a continuous function of x in (a, b) .

$$(2) \text{ We have } F(x+h) - F(x) = \int_x^{x+h} f(t) dt \\ = hf(\zeta), \text{ where } x \leq \zeta \leq x+h$$

since $f(t)$ is continuous, [See *Cor. of (III)*]

$$\therefore \frac{F(x+h) - F(x)}{h} = f(\zeta), \text{ for } h \neq 0.$$

When $h \rightarrow 0$, $\zeta \rightarrow x$ and $f(\zeta) \rightarrow f(x)$, since $f(t)$ is continuous.

$$\therefore \lim_{h \rightarrow 0} \frac{F(x+h) - F(x)}{h} \text{ exists, and } = f(x),$$

$$\text{i.e., } F'(x) = f(x).$$

(3) Since $f(x)$ is continuous throughout (a, b) , as proved above,

$$F'(x) = f(x), \text{ i.e., } F'(x) = \phi'(x).$$

$$\therefore F'(x) - \phi'(x) = 0.$$

$$\text{Let } \psi(x) = F(x) - \phi(x).$$

$$\therefore \psi'(x) = 0 \text{ everywhere in } (a, b).$$

Hence, $\psi(x) \equiv F(x) - \phi(x) =$ a constant c , in $(a, x) \dots$ (i)

[See *Diff. Calculus, Art. 67, Ex. 1.*]

$$\text{When } x = a, \quad F(a) = \int_a^a f(t) dt = 0.$$

$$\text{Since from (i), } F(a) - \phi(a) = c, \quad \therefore -\phi(a) = c.$$

Consequently from (i), $F(x) = \phi(x) + c = \phi(x) - \phi(a)$,

$$\text{i.e., } \int_a^x f(t) dt = \phi(x) - \phi(a).$$

In particular,

$$\int_a^b f(t) dt = \phi(b) - \phi(a).$$

Note. The relation given in (3) is known as the *Fundamental theorem of Integral Calculus*. [For an alternative proof, See *Art. 64.*]

5. Change of variable in an integral.

To change the variable in the integral $\int_a^b f(x) (dx)$ by the substitution $x = \phi(t)$, it is necessary that

(i) $\phi(t)$ possesses a derivative at every point of the interval $\alpha \leq t \leq \beta$, where $\phi(\alpha) = a$ and $\phi(\beta) = b$, and $\phi'(t) \neq 0$ for any value t in (α, β) .

(ii) $f[\phi(t)]$ and $\phi'(t)$ are bounded and integrable in (α, β) .
When the above conditions hold good, then and then only we have

$$\int_a^b f(x) dx = \int_\alpha^\beta f[\phi(t)] \phi'(t) dt.$$

Illustration :

Let
$$I = \int_{-1}^{+1} \frac{dx}{1+x^2}.$$

Putting $x = \tan \theta$, we get
$$I = \int_{-\frac{1}{2}\pi}^{\frac{1}{2}\pi} d\theta = \frac{1}{2}\pi.$$

Putting $x = 1/t$, we get

$$I = - \int_{-1}^1 \frac{dt}{1+t^2} = -\frac{1}{2}\pi.$$

The reason for the discrepancy lies in the fact that $1/t$ does not possess a derivative at $t=0$, an interior point of $(-1, 1)$; in fact the function itself is undefined when $t=0$.

6. Primitives and Integrals.

If $\phi'(x) = f(x)$, then $\phi(x)$ is the *primitive* of $f(x)$. The *integral* of $f(x)$ on the other hand is $\lim_{n \rightarrow \infty} \sum f(\xi_r) \delta_r$, or symbolically

$\int_a^b f(x) dx$, *i.e.*, the analytical substitute for an area

in case $f(x)$ has a continuous graph.

The distinction between the two is that while integrals can be *calculated*, primitives cannot be calculated.

The question as to whether a primitive exists, and the question of the existence of an integral of $f(x)$ in (a, b) , are entirely independent questions. It is only in the case of continuous functions that they are the same.

Indefinite integrals can properly be described as the *Calculus of primitives*.

The connection between primitives and integrals is represented by the Fundamental theorem of Integral Calculus *viz.*,

$$\int_a^b F'(x) dx = F(b) - F(a).$$

Illustration :

$$(i) f(x) = x \sin \frac{1}{x^2} - \frac{1}{x} \cos \frac{1}{x^2}, \quad (x \neq 0) \\ = 0 \quad (x = 0).$$

Here, $\frac{d}{dx} \left\{ \frac{1}{2} x^2 \sin \frac{1}{x^2} \right\} = f(x)$ for $x \neq 0$ and $= 0$ for $x = 0$, so that primitive exists but $\int_{-1}^{+1} f(x) dx$ does not exist.

(ii) $f(x) = 0$ ($x \neq 0$), $= 1$ ($x = 0$); here in $(0, 1)$, $\int_0^1 f(x) dx$ exists, and $= 0$, but no primitive exists.

7. Illustrative Examples.

Ex. 1. Show that $\frac{1}{2} < \int_0^1 \frac{dx}{\sqrt{4-x^2+x^5}} < \frac{\pi}{6}$.

We have, $4 > 4 - (x^2 - x^5)$ in $(0, 1)$,

$$\text{or,} \quad \sqrt{4} > \sqrt{(4-x^2+x^5)}.$$

$$\therefore \frac{1}{\sqrt{4}}, \text{ i.e., } \frac{1}{2} < \frac{1}{\sqrt{4-x^2+x^5}}.$$

$$\therefore \int_0^1 \frac{1}{2} dx, \text{ i.e., } \frac{1}{2} < \int_0^1 \frac{dx}{\sqrt{4-x^2+x^5}}$$

Again, $4-x^2 < 4-x^2+x^6$ in $(0, 1)$.

$$\therefore \frac{1}{\sqrt{4-x^2}} > \frac{1}{\sqrt{4-x^2+x^6}}$$

$$\therefore \int_0^1 \frac{dx}{\sqrt{4-x^2}} > \int_0^1 \frac{dx}{\sqrt{4-x^2+x^6}}$$

$$\therefore \left[\sin^{-1} \frac{1}{2} x \right]_0^1 \text{ i.e., } \sin^{-1} \frac{1}{2}, \text{ i.e., } \frac{\pi}{6} > \int_0^1 \frac{dx}{\sqrt{4-x^2+x^6}}$$

Hence the result.

Ex. 2. If $\int_a^b f(x) dx$ exists, show that

$$\left| \int_a^b f(x) dx \right| \leq \int_a^b |f(x)| dx.$$

We have $|f(\xi_1)\delta_1 + f(\xi_2)\delta_2 + \dots + f(\xi_n)\delta_n|$

$$\leq |f(\xi_1)||\delta_1| + |f(\xi_2)||\delta_2| + \dots + |f(\xi_n)||\delta_n|$$

i.e., $|\Sigma f(\xi_r)\delta_r| \leq \Sigma |f(\xi_r)||\delta_r|$

$$\therefore Lt |\Sigma f(\xi_r)\delta_r| \leq \Sigma Lt |f(\xi_r)||\delta_r|.$$

$$\therefore \left| \int_a^b f(x) dx \right| \leq \int_a^b |f(x)| dx.$$

Otherwise :

Since $\int_a^b f(x) dx$ exists, $\therefore \int_a^b |f(x)| dx$ exists.

We have $-|f(x)| \leq f(x) \leq |f(x)|$

$$\therefore -\int_a^b |f(x)| dx \leq \int_a^b f(x) dx \leq \int_a^b |f(x)| dx$$

$$\text{i.e., } \left| \int_a^b f(x) dx \right| \leq \int_a^b |f(x)| dx.$$

SECTION B
A NOTE ON LOGARITHMIC & EXPONENTIAL
FUNCTIONS

1. Introduction.

The fundamental concepts of Calculus furnish a more adequate theory of the logarithmic and exponential functions than the methods adopted in elementary books. There exponential function is first introduced, and then logarithm is defined as the inverse function ; but in the treatment of these functions by the principles of Calculus, logarithm is first defined by means of a definite integral, and then exponential function is introduced as the inverse of logarithm. From the stand-point of these new definitions, certain important inequalities and limits can be obtained more easily and satisfactorily.

2. Logarithmic Function.

The *natural* logarithm $\log x$ is defined as

$$\log x = \int_1^x \frac{dt}{t}, \quad \dots \quad (1)$$

where x is any *positive number*, *i.e.*, $x > 0$.

Thus $\log x$ denotes the area under the curve $y = 1/t$ from $t = 1$ to $t = x$.

From the definition it follows that $\log 1 = 0$, and [\because $1/t$ is continuous for $t > 0$], from the fundamental theorem of Integral Calculus it follows that $\log x$ is a continuous function and has a derivative given by

$$\frac{d}{dx} (\log x) = \frac{1}{x}. \quad \dots \quad (2)$$

Since the derivative is always positive, $\log x$ increases steadily with x (*i.e.*, $\log x$ is a monotone increasing function).

Putting $t = 1/u$ in the integral for x , we get

$$\log x = \int_1^x \frac{dt}{t} = - \int_1^{1/x} \frac{du}{u} = - \log \frac{1}{x} \quad \dots \quad (3)$$

Putting $t = yu$ [$y =$ a fixed number > 0] in the integral for $\log(xy)$, we get

$$\begin{aligned} \log(xy) &= \int_1^{xy} \frac{dt}{t} = \int_{1/y}^x \frac{du}{u} = \int_1^x \frac{du}{u} - \int_1^{1/y} \frac{du}{u} \\ &= \log x - \log(1/y) = \log x + \log y. \quad \dots \quad (4) \end{aligned}$$

In this way, other well-known properties of logarithms can be developed.

Since $\log x$ is a continuous monotone function of x , having the value 0 for $x = 1$, and tending to infinity as x increases, there must be some number greater than 1, such that for this value of x we have $\log x = 1$, and this number is called e . Thus e is defined by the equation

$$\log e = 1, \text{ i.e., } \int_1^e \frac{dt}{t} = 1. \quad \dots \quad (5)$$

3. Exponential Function.

If $y = \log x$, then we write $x = e^y$ \dots \dots (6) and in this way the exponential e^y is defined for all real values of y . In particular $e^0 = 1$, since $\log 1 = 0$. As y is a continuous function of x , x is a continuous function of y .

$$\begin{aligned} x &= e^y, & \text{so that } y &= \log x, \text{ and so} \\ \frac{dy}{dx} &= \frac{1}{x}; & \therefore \frac{dx}{dy} &= 1 \Big/ \frac{dy}{dx} = x = e^y \\ \text{i.e., } \frac{d}{dy} (e^y) &= e^y. & \dots & \dots \quad (7) \end{aligned}$$

More generally, $\frac{d}{dy} (e^{ay}) = ae^{ay}$

a^x ($a > 0$) is defined as $e^{x \log a}$, so that $\log a^x = x \log a$.

Thus, $10^x = e^{x \log 10}$.

The inverse function of a^y is called the *logarithm to the base a*.

Thus, if $x = a^y$, $y = \log_a x$.

4. Some Inequalities and Limits.

(i) To prove $2 < e < 3$.

For $\int_1^2 \frac{dt}{t}$, $1 < t < 2$; $\therefore \frac{1}{2} < 1/t < 1$.

$\therefore \int_1^2 \frac{dt}{t} < \int_1^2 dt$, i.e., < 1 , i.e., $< \int_1^e \frac{dt}{t}$. $\therefore 2 < e$

$$\begin{aligned} \int_1^3 \frac{dt}{t} &= \int_1^2 \frac{dt}{t} + \int_2^3 \frac{dt}{t} = \int_0^1 \frac{du}{2-u} + \int_0^1 \frac{du}{2+u} \\ &= 4 \int_0^1 \frac{du}{4-u^2} > 4 \int_0^1 \frac{du}{4}, \text{ i.e., } > 1, \text{ i.e., } > \int_1^e \frac{dt}{t}, \end{aligned}$$

$\therefore 3 > e$.

(ii) To prove $\frac{x}{1+x} < \log(1+x) < x$ ($x > 0$).

From definition, $\log(1+x) = \int_1^{1+x} \frac{dt}{t}$.

$\therefore 1 < t < 1+x$. $\therefore 1/(1+x) < 1/t < 1$.

$\therefore \frac{1}{1+x} \int_1^{1+x} dt < \int_1^{1+x} \frac{dt}{t} < \int_1^{1+x} dt$,

i.e., $\frac{1}{1+x} < \log(1+x) < x$.

(iii) To prove $\lim_{x \rightarrow 0} \frac{1}{x} \log(1+x) = 1$.

From (ii), $\frac{1}{1+x} < \frac{\log(1+x)}{x} < 1$, and since $1/(1+x)$ and 1 both tend to 1 as $x \rightarrow 0$, the reqd. limit = 1 .

(iv) To prove $\lim_{x \rightarrow 0} \frac{a^x - 1}{x} = \log a$.

Since the derivative of a^x is $a^x \log a$, and that for $x=0$ is $\log a$, it follows from the definition of the derivative for $x=0$, that

$$\lim_{h \rightarrow 0} \frac{a^h - a^0}{h}, \text{ i.e., } \lim_{h \rightarrow 0} \frac{a^h - 1}{h} = \log a.$$

Putting x for h , the required result follows.

When $a=e$, we get $\lim_{x \rightarrow 0} \frac{e^x - 1}{x} = 1$.

(v) To prove $\lim_{n \rightarrow \infty} \left(1 + \frac{x}{n}\right)^n = e^x$.

Since, $\frac{d}{dt} \log(1+xt) = \frac{x}{1+xt}$, it follows that the derivative of $\log(1+xt)$ for $t=0$ is x . Hence, from the definition of the derivative for $x=0$, we get

$$\lim_{h \rightarrow 0} \frac{\log(1+xh)}{h} = x.$$

Putting $h=1/\zeta$, we see that

$$\lim_{\zeta \rightarrow \infty} \zeta \log\left(1 + \frac{x}{\zeta}\right), \text{ i.e., } \lim_{\zeta \rightarrow \infty} \log\left(1 + \frac{x}{\zeta}\right)^\zeta = x.$$

Since the exponential function is continuous, it follows

$$\lim_{\zeta \rightarrow \infty} \left(1 + \frac{x}{\zeta}\right)^\zeta = e^x.$$

If we suppose $\zeta \rightarrow \infty$ through positive integral values only, the required result follows.

Putting $x=1$, we get $\lim_{n \rightarrow \infty} \left(1 + \frac{1}{n}\right)^n = e$.

(vi) To prove $\lim_{n \rightarrow \infty} n(\sqrt[n]{x} - 1) = \log x$.

Since the derivative of $e^y = e^y$, and that for $y=0$ is 1, we have from the definition of the derivative for $y=0$,

$$\lim_{h \rightarrow 0} \frac{e^h - e^0}{h}, \text{ i.e., } \lim_{h \rightarrow 0} \frac{e^h - 1}{h} = 1.$$

Putting z/n for h where z is any arbitrary number, and n ranges over the sequence of positive integers, we get,

$$\lim_{n \rightarrow \infty} \left\{ n \frac{e^{z/n} - 1}{z} \right\} = 1, \text{ i.e., } \lim_{n \rightarrow \infty} n(\sqrt[n]{e^z} - 1) = z.$$

Putting $z = \log x$, so that $e^z = x$, the required result follows.

(vii) To prove $\lim_{x \rightarrow \infty} \frac{\log x}{x^a} = 0$, when $a > 0$.

If $t > 1$ and $\beta > 0$, $t^{-1} < t^{\beta-1}$.

$$\therefore \log x = \int_1^x \frac{dt}{t} < \int_1^x t^{\beta-1} dt, \text{ i.e., } < \frac{x^\beta - 1}{\beta}, \text{ i.e., } < \frac{x^\beta}{\beta} \text{ for } x > 1.$$

Suppose $a > \beta$.

$$\therefore 0 < \frac{\log x}{x^a} < \frac{x^\beta}{\beta x^a}, \text{ i.e., } < \frac{1}{\beta} \cdot \frac{1}{x^{a-\beta}} \text{ for } x > 1.$$

But $(1/x^{a-\beta}) \rightarrow 0$, as $x \rightarrow \infty$, since, $a > \beta$.

Hence the result.

Note. Replacing x by n where n is a positive integer,

$$\lim_{n \rightarrow \infty} \frac{\log n}{n^a} = 0, \text{ when } a > 0 \text{ (} n \rightarrow \infty \text{ through positive integral}$$

values).

(viii) To prove $\lim_{y \rightarrow \infty} \frac{y^a}{e^y} = 0$, for all values of n , however great.

From (vii), $x^{-\beta} \log x \rightarrow 0$, when $x \rightarrow \infty$, for $\beta > 0$.

Putting $a = 1/\beta$ in the left side, and raising it to the power a , we get

$x^{-1} (\log x)^a \rightarrow 0$, as $x \rightarrow \infty$. Now putting $x = e^y$, so that $\log x = y$, the required result follows.

SECTION C

ALTERNATIVE PROOFS OF SOME THEOREMS

1. Alternative proof of Art. 9'3.

Let AB be the curve, OA and OB be the radii vectores corresponding to $\theta = \alpha$ and $\theta = \beta$.

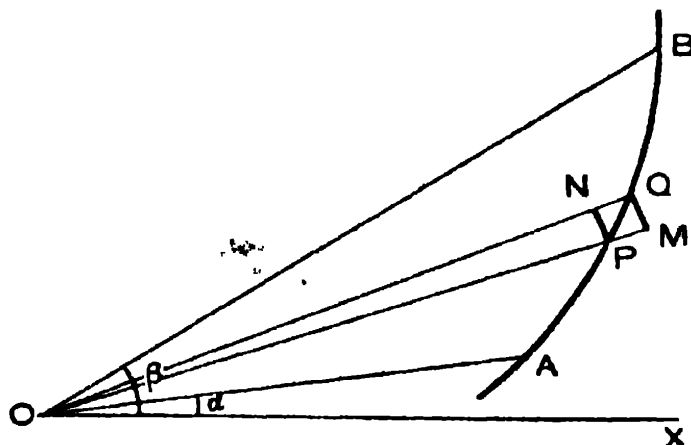

Divide $\beta - \alpha$ into n parts, each equal to h and draw the

corresponding radii vectores. Let P and Q be the points on the curve corresponding to $\theta = a + rh$ and $\theta = a + (r + 1)h$ and let us suppose θ goes on increasing from a to β . With centre O and radii OP , OQ respectively draw arcs PN , QM as in the figure. Then the area OPQ lies in magnitude between

$$\frac{1}{2}OP^2 \cdot h \text{ and } \frac{1}{2}OQ^2 \cdot h$$

i.e., between $\frac{1}{2} [f\{a + rh\}]^2 h$ and $\frac{1}{2} [f\{a + (r + 1)h\}]^2 h$.

Hence, adding up all the areas like OPQ , it is clear that the area AOB lies between

$$\frac{1}{2} \sum_{r=0}^{n-1} [f\{a + rh\}]^2 h \text{ and } \frac{1}{2} \sum_{r=0}^{n-1} [f\{a + (r + 1)h\}]^2 h.$$

Now, let $n \rightarrow \infty$, so that $h \rightarrow 0$; then as the limit of each of the above two sums is

$$\frac{1}{2} \int_a^\beta \{f(\theta)\}^2 d\theta,$$

it follows that the area AOB is also equal to the definite integral.

2. Alternative proof of Art. 11'1.

(i) *Volume of a solid of revolution.*

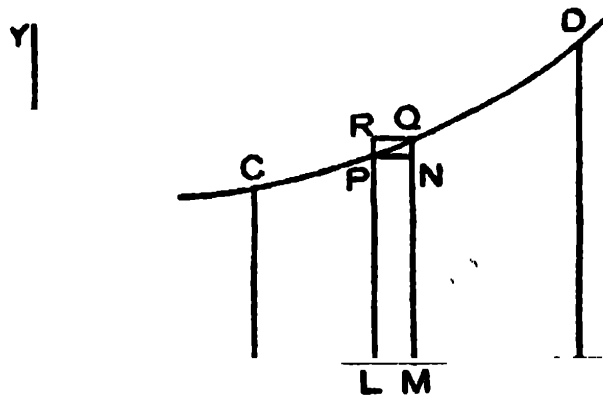

Let a curve CD whose equation is $y = f(x)$, be rotated about the x -axis so as to form a solid of revolution. To find

the volume of the solid generated by the revolution, about the x -axis, of the area $ABDC$, bounded by the curve $y = f(x)$, the ordinates at A and B and the x -axis, let a and b be the abscissæ of C and D .

Divide AB into n equal parts, each equal to h , and draw ordinates at the points of division. Let the ordinates at $x = a + rh$ and $x = a + (r + 1)h$ be PL and QM , and let us suppose y goes on increasing as x increases from a to b .

Draw PN perpendicular on QM , and QR perpendicular on LP produced. Then the volume of the solid generated by the revolution of the area $LMQP$ lies in magnitude between the volumes generated by the rectangles $LMNP$ and $LMQR$,

i.e., between $\pi [f \{a + rh\}]^2 h$ and $\pi [f \{a + (r + 1)h\}]^2 h$.

Hence, adding up the volumes generated by all areas like $LMQP$, it is clear that the required volume lies in magnitude between

$$\pi \sum_{r=0}^{n-1} [f \{a + rh\}]^2 h \text{ and } \pi \sum_{r=0}^{n-1} [f \{a + (r + 1)h\}]^2 h.$$

Now, let $n \rightarrow \infty$, so that $h \rightarrow 0$; then as the limit of each of the above two sums is

$$\pi \int_a^b [f(x)]^2 dx, \text{ i.e., } \pi \int_a^b y^2 dx,$$

it follows that the required volume is also equal to this definite integral.

(ii) *Surface-area of a solid of revolution.*

Let the length of the arc from C up to any point $P(x, y)$ be s and suppose that surface-area of the solid generated

by the revolution of the arc CD about the x -axis is required. As in the case of the volume, divide AB into n equal parts, each equal to h , and erect ordinates at the points of division. Let the ordinates at $x = a + rh$ and $x = a + (r + 1)h$ be PL and QM , and let the arc PQ be equal to l . The surface-area of the solid generated by the revolution of $LMQP$ about the x -axis lies in magnitude between the curved surface of two right circular cylinders, each of thickness l , one of radius PL and the other of radius QM , *i.e.*, between

$$2\pi f \{a + rh\} l \text{ and } 2\pi f \{a + (r + 1)h\} l.$$

Hence, adding up all surface-areas generated by elementary areas like PQ , it is clear that the required surface-area lies in magnitude between

$$2\pi \sum_{r=0}^{n-1} \frac{l}{h} f \{a + rh\} h \text{ and } 2\pi \sum_{r=0}^{n-1} \frac{l}{h} f \{a + (r + 1)h\} h.$$

Now, let $n \rightarrow \infty$, so that $h \rightarrow 0$; then $\frac{l}{h}$ tending to $\frac{ds}{dx}$, the limit of each of the above two sums is

$$2\pi \int_a^b f(x) \frac{ds}{dx} dx, \text{ i.e., } 2\pi \int_a^b y ds.$$

Hence, the required surface-area is also equal to this definite integral.

3. Alternative proof of Ex. 3, Art. 9'3.

Show that the area between the folium of Descartes and its asymptote is equal to the area of its loop, each being equal to $\frac{2}{3}a^2$.

The equation of the folium is $x^3 + y^3 = 3axy$.

Turn the axes through $\frac{1}{4}\pi$; that is substitute

$$(x - y)/\sqrt{2} \text{ and } (x + y)/\sqrt{2}$$

for x and y respectively. Then the given equation transforms into

$$y^2 = \frac{x^2}{3} \cdot \frac{3c-x}{c+x}, \quad \text{where } c = \frac{1}{\sqrt{2}} a.$$

$$\therefore y = \frac{1}{\sqrt{3}} x \sqrt{\left(\frac{3c-x}{c+x}\right)}.$$

Here, $c+x=0$, i.e., $x=-c$ is the equation of the asymptote MN

$$OA=3c, \quad OD=c.$$

\therefore the required area σ between the Folium and the asymptote

$$\begin{aligned} &= 2 \lim_{t \rightarrow c} \int_{-t}^0 y \, dx = \frac{2}{\sqrt{3}} \lim_{t \rightarrow c} \int_{-t}^0 x \sqrt{\left(\frac{3c-x}{c+x}\right)} \, dx \\ &= \frac{2}{\sqrt{3}} \lim_{t \rightarrow c} \int_{-t}^0 \frac{x(3c-x)}{\sqrt{(x+c)(3c-x)}} \, dx. \end{aligned}$$

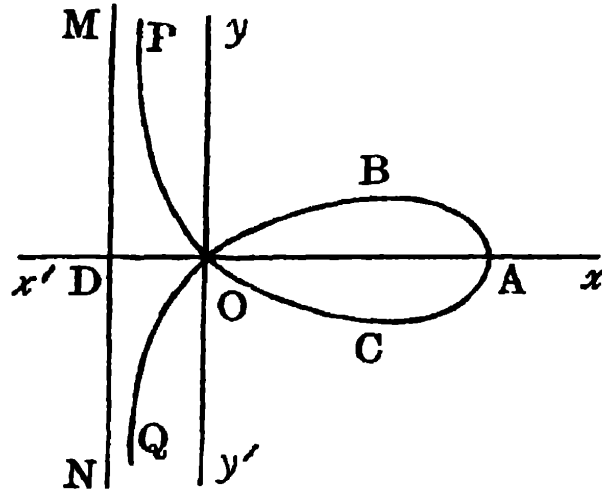

$$\begin{aligned} \text{Let } I &= \int \frac{x(3c-x)}{\sqrt{(x+c)(3c-x)}} \, dx = 2c^2 \int (1-2\cos\theta)(1+\cos\theta) \, d\theta, \\ &\quad \left[\text{on putting } x = c - 2c \cos \theta, \text{ so that } \cos \theta = \frac{c-x}{2c} \right] \\ &= -2c^2 \int (\cos\theta + \cos 2\theta) \, d\theta \\ &= -2c^2 \left(\sin\theta + \frac{1}{2} \sin 2\theta \right) \\ &= -2c^2 \left\{ \sin \left(\cos^{-1} \frac{c-x}{2c} \right) + \frac{1}{2} \sin \left(2 \cos^{-1} \frac{c-x}{2c} \right) \right\}. \\ \therefore \sigma &= \frac{2}{\sqrt{3}} - 2c^2 \lim_{t \rightarrow c} \left[\sin \left(\cos^{-1} \frac{c-x}{2c} \right) + \frac{1}{2} \sin \left(2 \cos^{-1} \frac{c-x}{2c} \right) \right]_{-t}^0 \\ &= 2a^2 \cdot \frac{3}{4} \left[\text{on putting } c = \frac{1}{\sqrt{2}} a \right] \\ &= \frac{3}{4} a^2. \end{aligned}$$

Again L , the area of the loop $OPAQ$

= 2 area of the portion OPA

$$= 2 \int_0^{3c} y \, dx = \frac{2}{\sqrt{3}} \int_0^{3c} \frac{x(3c-x)}{\sqrt{(x+c)(3c-x)}} \, dx.$$

Putting as before $x = c - 2c \cos \theta$,

$$\begin{aligned} L &= \frac{2}{\sqrt{3}} - 2c^2 \left[\sin \left(\cos^{-1} \frac{c-x}{2c} \right) + \frac{1}{2} \sin \left(2 \cos^{-1} \frac{c-x}{2c} \right) \right]_0^{3c} \\ &= \frac{4c^2}{\sqrt{3}} \cdot \frac{3}{2} \cdot \frac{\sqrt{3}}{2} = \frac{3}{2} a^2 \left[\text{on putting } c = \frac{1}{\sqrt{2}} a \right] \end{aligned}$$

4. Proof of the result of Art. 17.5(f).

When $X = xV$, where V is any function of x ,

$$\text{then, } \frac{1}{f(D)} xV = \left\{ x - \frac{1}{f(D)} f'(D) \right\} \frac{1}{f(D)} V.$$

We have, $D(xV) = xDV + V$

$$D^2(xV) = D(xDV) + DV = xD^2V + 2DV$$

and similarly, $D^n(xV) = xD^nV + nD^{n-1}V$

$$= xD^nV + \left(\frac{d}{dD} D^n \right) V. \quad \dots (1)$$

$$\text{Hence, } f(D) xV = x f(D) V + f'(D) V. \quad \dots (2)$$

Now, put $f(D) V = V_1$; hence $V = \frac{1}{f(D)} V_1$

\therefore (2) becomes

$$\begin{aligned} f(D) x \frac{1}{f(D)} V_1 &= xV_1 + f'(D) \frac{1}{f(D)} V_1 \\ \text{i.e., } x \frac{1}{f(D)} V_1 &= \frac{1}{f(D)} xV_1 + \frac{1}{f(D)} f'(D) \frac{1}{f(D)} V_1. \end{aligned}$$

Transposing, we get

$$\frac{1}{f(D)} xV_1 = \left\{ x - \frac{1}{f(D)} f'(D) \right\} \frac{1}{f(D)} V_1.$$

Dropping suffix, we get

$$\frac{1}{f(D)} xV = \left\{ x - \frac{1}{f(D)} f'(D) \right\} \frac{1}{f(D)} V.$$

SECTION D

A NOTE ON INTEGRATING FACTORS

1. Rules for determining Integrating Factors.

Let the differential equation be

$$M dx + N dy = 0. \quad \dots \quad \dots \quad (1)$$

The condition that it should be *exact*, is

$$\frac{\partial M}{\partial y} = \frac{\partial N}{\partial x} \quad \dots \quad \dots \quad (2)$$

Rule (I). If $\frac{\frac{\partial M}{\partial y} - \frac{\partial N}{\partial x}}{N}$ is a function of x only,

say $f(x)$, then

$e^{\int f(x) dx}$ will be an *integrating factor* of (1).

If $M dx + N dy = 0$, be an *exact* equation when multiplied by $e^{\int f(x) dx}$ then, we must have

$$\frac{\partial}{\partial y} (M e^{\int f(x) dx}) = \frac{\partial}{\partial x} (N e^{\int f(x) dx})$$

i.e.,
$$\frac{\partial M}{\partial y} e^{\int f(x) dx} = \frac{\partial N}{\partial x} e^{\int f(x) dx} + N e^{\int f(x) dx} f(x)$$

i.e.,
$$\frac{\frac{\partial M}{\partial y} - \frac{\partial N}{\partial x}}{N} = f(x).$$

Rule (II). If $\frac{\frac{\partial N}{\partial x} - \frac{\partial M}{\partial y}}{M} = f(y)$, (a function of y alone)

$e^{\int f(y) dy}$ is an *integrating factor*.

Proof is similar to that given above.

Rule (III). If M and N are both homogeneous functions in x, y of degree n (say), then

$$\frac{1}{Mx + Ny}, \quad (Mx + Ny \neq 0)$$

is an *integrating factor* of the equation (1).

We can easily show that

$$\frac{\partial}{\partial y} \left(\frac{M}{Mx + Ny} \right) = \frac{\partial}{\partial x} \left(\frac{N}{Mx + Ny} \right)$$

if we remember that M and N are homogeneous functions of degree n and hence $x \frac{\partial M}{\partial x} + y \frac{\partial M}{\partial y} = nM$

$$\text{and } x \frac{\partial N}{\partial x} + y \frac{\partial N}{\partial y} = nN.$$

If $Mx + Ny = 0$, then $\frac{M}{N} = -\frac{y}{x}$ and the equation reduces to

$$y dx - x dy = 0$$

which can be easily solved.

Rule (IV). If the equation (1) is of the form

$$y f(xy) dx + x g(xy) dy = 0$$

then $\frac{1}{Mx - Ny}, \quad (Mx - Ny \neq 0)$

is an *integrating factor* of (1).

We can easily show that

$$\frac{\partial}{\partial y} \left(\frac{M}{Mx - Ny} \right) = \frac{\partial}{\partial x} \left(\frac{N}{Mx - Ny} \right),$$

$$i.e., \frac{\partial}{\partial y} \left[\frac{y f(xy)}{xy \{f(xy) - g(xy)\}} \right] = \frac{\partial}{\partial x} \left[\frac{xg(xy)}{xy \{f(xy) - g(xy)\}} \right]$$

provided we remember $y \frac{\partial}{\partial y} F(xy) = x \frac{\partial}{\partial x} F(xy)$.

If however $Mx - Ny = 0$, then $\frac{M}{N} = \frac{y}{x}$ and the equation reduces to

$$x dy + y dx = 0$$

which can be easily solved.

2. Illustrative Examples.

Ex. 1. Solve : $(2x^2 + y^2 + x) dx + xy dy = 0$.

Here $\frac{\partial M}{\partial y} = 2y$; $\frac{\partial N}{\partial x} = y$. \therefore the equation is not exact.

$$\text{Now, } \frac{\frac{\partial M}{\partial y} - \frac{\partial N}{\partial x}}{N} = \frac{2y - y}{xy} = \frac{1}{x}.$$

\therefore by Rule (I), I. F. = $e^{\int \frac{1}{x} dx} = e^{\log x} = x$.

Multiplying both sides of the given equation by x , we have

$$(2x^3 + xy^2 + x^2) dx + x^2 y dy = 0,$$

$$\text{or, } 2x^3 dx + x^2 dx + xy (y dx + x dy) = 0,$$

$$\text{or, } 2x^3 dx + x^2 dx + xy d(xy) = 0,$$

$$\text{or, } 2x^3 dx + x^2 dx + z dz = 0, \text{ where } z = xy.$$

$$\therefore \text{ integrating, } \frac{x^4}{2} + \frac{x^3}{3} + \frac{z^2}{2} = c_1.$$

$$\therefore \text{ reqd. solution is } 3x^4 + 2x^3 + 3x^2 y^2 = c.$$

Ex. 2. Solve : $(x^3 + y^3) dx - xy^3 dy = 0$.

Here, $\frac{\partial M}{\partial y} = 3y^2$; $\frac{\partial N}{\partial x} = -y^3$. \therefore the equation is not exact.

Now, $\frac{1}{Mx + Ny} = \frac{1}{x^4 + xy^3 - xy^3} = \frac{1}{x^4}$.

The equation is homogeneous.

\therefore by Rule (III), $\frac{1}{x^4}$ is an integrating factor.

Multiplying both sides of the given equation by $\frac{1}{x^4}$, we have

$$\left(\frac{1}{x} + \frac{y^3}{x^4} \right) dx - \frac{y^3}{x^4} dy = 0.$$

This is exact.

$$\text{Now, } \int M dx = \int \left(\frac{1}{x} + \frac{y^3}{x^4} \right) dx = \log x - \frac{1}{3} \frac{y^3}{x^3}$$

$$\int N dy = -\frac{1}{3} \frac{y^3}{x^3}.$$

\therefore by Art. 15.5, the solution is

$$\log x - \frac{1}{3} \frac{y^3}{x^3} = c, \text{ i.e., } y^3 = 3x^3 \log x + cx^3.$$

INDEX

- Acceleration, 376
- Appendix, 387
- Applications, 372
- Area between two curves
 - cartesian, 211
 - polar, 217
- Areas of closed curves, 227
- Areas of plane curves
 - cartesian, 205
 - polar, 216, 363
- Area of
 - cardioid, 217
 - cissoïd, 222
 - cycloid, 209
 - ellipse, 207, 213
 - folium of Descartes, 219
 - parabola, 208
 - loop, cartesian eqn., 210
 - loop, polar eqn., 218
- Astroid, 290
- Auxiliary equation, 341
 - equal roots, 341
 - pair of complex roots, 342
 - real and distinct roots, 341
- Bernoulli's equation, 327
- Beta function, 173, 182
- Binomial differentials, 179
- By parts integration, 38
- Cardioid, 297
- Catenary, 289
- Centroid, 273
 - circular arc, 274
 - parabolic lamina, 275
 - quadrant of an ellipse, 276
 - solid hemisphere, 277
- Chainette, 289
- Change of variables, 14, 355
- Cissoïd, 295
- Clairaut's equation, 335
- Complementary function, 318, 331
- Complete primitive, 305
- Condition for integrability, 388
- Constant of integration, 3
- Convergent integral, 133
- Cycloid
 - vertex downwards, 287
 - vertex upwards, 286
- Darboux's theorem, 388
- Definite integrals, 2, 91, 93, 102, 349
 - as the limit of a sum, 91
 - general properties, 117
 - geometrical interpretation, 99
 - lower limit, 3, 92
 - upper limit, 3, 92
- Differential equations,
 - definitions, 302
 - degree, 303
 - exact, 320
 - first degree, 310
 - first order, 310
 - formation, 303
 - geometrical interpretation, 305

- homogeneous, 315
- n th order, 363
- order, 303
- ordinary, 302
- partial, 302
- resolvable into factors, 332
- second order, 340
- solution, 305
- solvable for x, y , 333
- Delta function, 134
- Divergent integral, 133

- Elementary rules of Integration, 4
- Equations of second order, 340
 - special type, 325
- Equiangular spiral, 296
- Eulerian integral, 173
- Evolutes, parabola, 292
- Exact equation, 320
- Exponential curves, 294
- Exponential function, 360

- First mean value theorem
 - of integral calculus, 390, 392
- First principle, 93
- Folium of Descartes', 293
- Fundamental integrals, 6
- Fundamental theorem, 1, 101, 355

- Gamma function, 183
- Geometrical interpretation
 - definite integral, 99
 - differential eqn., 305
- General laws of integration, 5
- General solution, 305
- Generalised definition, 93

- Homogeneous equation, 315
 - special form, 316
- Hyperbolic function, 25, 66
- Hypo cycloid, 291

- Improper integrals, 132
 - convergent, divergent
 - oscillatory, 133
- Inequalities and limits, 361
- Interior limit, 92
- Infinite range, 132
- Integrability, 388
 - necessary and sufficient condition, 388
- Integrable function, 350
- Integrating factors, 321, 323
- Integrals
 - definite, 3, 92, 93, 102, 349
 - Eulerian, 173
 - improper, 132
 - indefinite, 1, 2
 - infinite, 132
 - Riemann, 388
- Integration, 2
 - as the limit of a sum, 91
 - by parts, 38
 - from first principle, 93
 - of infinite series, 140
 - of power series, 140
 - of rational fraction, 78
- Intrinsic equation of
 - cardioid, 253
 - catenary, 252
 - cycloid, 252
- Intrinsic equation to a curve from cartesian eqn., 249

- pedal eqn., 251
 polar eqn., 250
 Isocline, 347
- Length of arc of
 cardioid, 245
 cycloid, 243
 evolute, 247
 loop, 243
 parabola, 242
- Length of plane curve from
 cartesian, 240
 parametric, 241
 pedal, 246
 polar, 244
- Lemniscate, 299
- Limits, 92, 361
- Limacon, 298
- Line integral, 229
- Linear equation, 299, 340
- Logarithmic curve, 294
- Logarithmic spiral, 265
- Lower integral, 387
- Method of substitution,
 definite integral, 104
 indefinite integral, 14
- Miscellaneous application, 341
- Moment of inertia, 273
 circular plate, 281
 elliptic lamina, 281
 rectangular lamina, 280
 sphere, 282
 thin uniform rod, 279
- On some well-known curves, 286
- Orthogonal trajectories, 372
 cartesian eqn., 372
 polar eqn., 373
- Pappus' theorem, 267
- Parabolic rule, 232
- Particular integrals, 346, 347, 363
 methods, 320
- Perfect differential, 320
- Primitives and integrals, 356
- Principal value, 134, 137
- Probability curves, 294
- Radius of gyration, 279
- Rational fractions, 78
- Rectification, 240
- Reduction formulæ, 125, 163
 double parameter, 171
 single parameter, 164
 special devices, 177
- Riemann integral, 386
- Rose petal, 300
- Series represented by definite
 integral, 107
- Separation of variables, 310
- Sign of an area, 225
- Simpson rule, 229
- Sine spiral, 301
- Singular solution, 306, 335, 336
- Solids of revolution, 259, 264
 volume, 260, 264
- Some well-known curves, 265
- Special trigonometric function, 57
- Spiral of Archimedes, 297
- Standard integrals, 24, 41, 43, 59

- Strophoid**, 304
Superior limit, 92
Surface-area, 239, 365
Summation of series, 107
Symbolical operation, 348
Symbolical operators, 347
- Tractrix**, 290
Trial solution, 340
- Upper integral**, 349
Upper limit, 3, 92
- Velocity**, 376
Volumes, 259, 364
Volume and surface-area
 cardioide, 264
 cycloid, 263
 parabola, 261, 262
- Witch of Agnesi**, 296
-

INTEGRAL CALCULUS
INCLUDING
DIFFERENTIAL EQUATIONS

OUR COLLEGE PUBLICATIONS

By Das & Mukherjee

1. INTERMEDIATE STATICS
2. INTERMEDIATE DYNAMICS
3. INTERMEDIATE TRIGONOMETRY
4. HIGHER TRIGONOMETRY
5. DIFFERENTIAL CALCULUS
6. A SHORT COURSE OF COMPLEX VARIABLES
& HIGHER TRIGONOMETRY
7. ANALYTICAL DYNAMICS OF A PARTICLE
8. ELEMENTARY CO-ORDINATE AND SOLID
GEOMETRY
9. PRE-UNIVERSITY TRIGONOMETRY

By Ganguli & Mukherjee

10. INTERMEDIATE ALGEBRA
11. PRE-UNIVERSITY ALGEBRA

By S. Mukherjee & N. Das

12. KEY TO INTERMEDIATE TRIGONOMETRY
13. KEY TO PRE-UNI. INTER TRIGONOMETRY
14. KEY TO INTERMEDIATE DYNAMICS
15. KEY TO INTERMEDIATE STATICS
16. KEY TO HIGHER TRIGONOMETRY
17. KEY TO DIFFERENTIAL CALCULUS
18. KEY TO COMPLEX VARIABLES

By P. K. Das

19. KEY TO ANALYTICAL DYNAMICS OF A PARTICLE

By An Experienced Graduate

20. KEY TO INTERMEDIATE ALGEBRA
21. KEY TO PRE-UNIVERSITY ALGEBRA
22. KEY TO INTEGRAL CALCULUS

